

MY 2021



LCV Range

Price Guide

Price and Specification Guide
21 January 2021. Model Year 2021.5



Combo Cargo

CONTENTS

To find the information you want use the links below to navigate around the guide:

[Range Highlights](#)

[Models](#)

[Prices and Weights](#)

[Fuel Economy and Emissions](#)

[Features and Options](#)

[Exterior Colours](#)

[Wheels and Tyres](#)

[Specifications](#)

[Dimensions](#)

[Accessories](#)

[Glossary of Terms](#)

[Further Information](#)

COMBO CARGO RANGE HIGHLIGHTS



VX_COMV_29785

EDITION OTR from £18,483.33*

Standard features include:

Infotainment:

- AM/FM/DAB digital radio, Bluetooth® audio streaming, Bluetooth® mobile phone portal, USB audio connection with 3.5-inch display
- Vauxhall Connect

Interior convenience/styling:

- Steering column adjustable for reach and rake

Exterior convenience/styling:

- Electrically adjustable/heated door mirrors
- Electrically operated front windows
- Nearside sliding side-access door – L1 models
- Nearside and offside sliding side-access doors – L2 models
- Twin solid rear doors
- Emergency tyre inflation kit
- Side-protection mouldings

Safety/security:

- Driver's airbag
- Anti-lock braking system
- Hill start assist
- Full-height steel bulkhead
- Daytime running lights
- Automatic lighting control
- Remote control central deadlocking
- Keyless entry and start – standard on Automatic models
- Engine deadlock immobiliser
- Electronically protected audio equipment



VX_COMV_28900

DYNAMIC OTR from £19,483.33*

Features over Edition:

Interior convenience/styling:

- Steering wheel mounted audio controls
- Air conditioning
- Driver's top-lidded glovebox
- Height-adjustable driver's seat with manual lumbar adjustment
- Four-way adjustable passenger's seat
- Electronic cruise control

Exterior convenience/styling:

- Rear parking distance sensors

Security:

- Remote control security alarm system

4x4 (Edition) models**

additionally feature:

- Selectable 4x4 drive system with viscous-coupling
- ECO front-wheel drive mode
- Increased ground clearance 185mm
- Underbody protection for engine, gearbox and fuel tank



VX_COMV_28911

SPORTIVE OTR from £20,558.33*

Features over Edition:

Infotainment:

- Multimedia audio system – 8-inch colour touchscreen

Interior convenience/styling:

- Steering wheel mounted audio controls
- Air conditioning
- Driver's top-lidded glovebox
- Height-adjustable driver's seat with manual lumbar adjustment
- Dual front passengers' fixed bench seat
- Electronic cruise control
- Electric parking brake
- FlexCargo bulkhead

Exterior convenience/styling:

- Rear parking distance sensors
- Body-colour front and rear bumpers
- Metallic paint
- 16-inch steel wheels with full-diameter wheel trims
- Front fog lights

Security:

- Remote control security alarm system

Crew Van (Edition and Sportive) models

additionally feature:

- Two-position moveable ladder frame bulkhead
- Three-seat second-row bench
- Lap and diagonal inertia-reel seatbelts
- Nearside and offside sliding side-access doors



VX_COMV_31426

ELITE OTR from £22,733.33*

Features over Sportive:

Infotainment:

- Multimedia Navi Pro – Satellite navigation system

Interior convenience/styling:

- Sight and Light Pack
- Vinyl load floor covering
- Surround rear vision

Exterior convenience/styling:

- Body-colour side-protection mouldings
- Body-colour door handles
- Body-colour sliding side-access door rail cover
- 16-inch alloy wheels
- Front and rear parking distance sensors
- Tyre pressure monitoring system

*OTR price excluding VAT.

**For specific warranty details see Combo 4x4 prices page.

EDITION



VX_COMV_29785

L1 PANEL VAN ON-THE-ROAD PRICES

EURO 6D (6.3)	OTR RRP exc. VAT	Insurance Group
Petrol*		
2000 1.2 (110PS) Turbo Start/Stop	£18,533.33	29A
EURO 6D TEMP (6.2)		
Diesel		
2000 1.5 (75PS) Turbo D	£18,483.33	30A
2000 1.5 (100PS) Turbo D	£19,008.33	30A
2300 1.5 (75PS) Turbo D	£18,833.33	30A
2300 1.5 (100PS) Turbo D	£19,358.33	30A
2300 1.5 (130PS) Turbo D Start/Stop	£20,008.33	31A
2300 1.5 (130PS) Turbo D Start/Stop Automatic	£21,958.33	32A
2300 1.5 (130PS) Turbo D Start/Stop 4x4**	£36,163.33	36A

L2 PANEL VAN ON-THE-ROAD PRICES

EURO 6D TEMP (6.2)		
Diesel		
2300 1.5 (100PS) Turbo D	£20,558.33	30A
2300 1.5 (130PS) Turbo D Start/Stop Automatic	£23,158.33	30A
2300 1.5 (130PS) Turbo D Start/Stop 4x4**	£37,363.33	34A

Please note: On-the-road recommended retail prices (RRP) include number plates and delivery to Retailer of £583.33, 12 months' Vehicle Excise Duty (£265.00) and new vehicle first registration fee of £55.00. Excludes fuel and insurance.

*Petrol model ends production in May. **For specific warranty details see Combo 4x4 prices page.

FEATURES

Infotainment:

- AM/FM/DAB digital radio
- Bluetooth® audio streaming
- Bluetooth® mobile phone portal
- USB audio connection
- Four speakers
- Vauxhall Connect

Interior convenience/styling:

- Steering column adjustable for reach and rake
- Full-width overhead storage shelf
- Four-way adjustable driver's seat
- Front passenger's seat with underseat storage

Exterior convenience/styling:

- Electrically adjustable/heated door mirrors
- Electrically operated front windows with one-touch facility
- Nearside sliding side-access door
- Twin solid rear doors
- Emergency tyre inflation kit
- Side-protection mouldings
- 15-inch steel wheels with centre caps (2000 models)
- 16-inch steel wheels with centre caps (2300 models)

Safety/security:

- Driver's airbag
- Height-adjustable front lap and diagonal inertia-reel seatbelts
- Electronic stability programme with traction control
- Anti-lock braking system
- Full-height steel bulkhead
- Hill start assist
- Daytime running lights
- Remote control central deadlocking
- Keyless entry and start – standard on Automatic models
- Engine deadlock immobiliser
- Electronically protected audio equipment

DYNAMIC



VX_COMV_28900

L1 PANEL VAN ON-THE-ROAD PRICES

EURO 6D TEMP (6.2)	OTR RRP exc. VAT	Insurance Group
Diesel		
2000 1.5 (75PS) Turbo D	£19,483.33	29E
2300 1.5 (75PS) Turbo D	£19,833.33	29E
2300 1.5 (100PS) Turbo D	£20,358.33	30E

L2 PANEL VAN ON-THE-ROAD PRICES

EURO 6D TEMP (6.2)	OTR RRP exc. VAT	Insurance Group
Diesel		
2300 1.5 (100PS) Turbo D	£21,558.33	31E

Please note: On-the-road recommended retail prices (RRP) include number plates and delivery to Retailer of £583.33, 12 months' Vehicle Excise Duty (£265.00) and new vehicle first registration fee of £55.00. Excludes fuel and insurance.

FEATURES

Infotainment:

- AM/FM/DAB digital radio
- Bluetooth® audio streaming
- Bluetooth® mobile phone portal
- USB audio connection
- Four speakers
- Vauxhall Connect

Interior convenience/styling:

- Steering column adjustable for reach and rake
- Full-width overhead storage shelf
- Steering wheel mounted audio controls
- Air conditioning
- Driver's top-lidded glovebox
- Electronic cruise control
- Steering wheel mounted audio controls
- Six-way adjustable driver's seat with manual lumbar adjustment and armrest
- Four-way adjustable front passenger's seat with underseat storage

Exterior convenience/styling:

- Electrically adjustable/heated door mirrors
- Electrically operated front windows with one-touch facility
- Nearside sliding side-access door
- Twin solid rear doors
- Rear parking distance sensors
- Emergency tyre inflation kit
- Side-protection mouldings
- 15-inch steel wheels with centre caps (2000 models)
- 16-inch steel wheels with centre caps (2300 models)

Safety/security:

- Driver's airbag
- Height-adjustable front lap and diagonal inertia-reel seatbelts
- Electronic stability programme with traction control
- Anti-lock braking system
- Full-height steel bulkhead
- Hill start assist
- Daytime running lights
- Remote control central deadlocking
- Keyless entry and start – standard on Automatic models
- Engine deadlock immobiliser
- Electronically protected audio equipment
- Remote control security alarm system

SPORTIVE



VX_COMV_28911

L1 PANEL VAN ON-THE-ROAD PRICES

EURO 6D TEMP (6.2)	OTR RRP exc. VAT	Insurance Group
Diesel		
2000 1.5 (75PS) Turbo D	£20,558.33	29E
2000 1.5 (100PS) Turbo D	£21,083.33	30E
2300 1.5 (130PS) Turbo D Start/Stop Automatic	£23,473.33	30E
2300 1.5 (100PS) Turbo D	£21,433.33	32E
2300 1.5 (130PS) Turbo D Start/Stop	£22,083.33	33E

L2 PANEL VAN ON-THE-ROAD PRICES

EURO 6D TEMP (6.2)	OTR RRP exc. VAT	Insurance Group
Diesel		
2300 1.5 (100PS) Turbo D	£22,633.33	29E

Please note: On-the-road recommended retail prices (RRP) include number plates and delivery to Retailer of £583.33, 12 months' Vehicle Excise Duty (£265.00) and new vehicle first registration fee of £55.00. Excludes fuel and insurance.

FEATURES

Infotainment:

- Multimedia audio system
 - 8-inch colour touchscreen
 - AM/FM/DAB digital radio
 - Bluetooth® audio streaming
 - Bluetooth® mobile phone portal
 - USB audio connection
 - Four speakers
- Vauxhall Connect

Interior convenience/styling:

- Air conditioning
- Driver's top-lidded glovebox
- Six-way adjustable driver's seat with manual lumbar adjustment and armrest
- Four-way adjustable front passenger's seat (Auto only)
- Dual front passengers' fixed bench seat (Manual only)
- Full-width overhead storage shelf
- Electronic cruise control
- Steering wheel mounted audio controls
- Steering column adjustable for reach and rake
- FlexCargo – Manual models only
 - Fold-flat centre seat backrest with table
 - Two-way foldable outer seat
 - Load-through bulkhead
 - Electric parking brake

Exterior convenience/styling:

- Electrically adjustable/heated door mirrors
- Electrically operated front windows with one-touch facility
- Front fog lights
- Nearside sliding side-access door
- Rear parking distance sensors
- Body-colour front and rear bumpers
- Twin solid rear doors
- Metallic paint
- 16-inch steel wheels with full-diameter wheel trims
- Emergency tyre inflation kit

Safety/security:

- Driver's airbag
- Height-adjustable front lap and diagonal inertia-reel seatbelts
- Electronic stability programme with traction control
- Anti-lock braking system
- Full-height steel bulkhead
- Hill start assist
- Daytime running lights
- Remote control central deadlocking
- Remote control security alarm system
- Keyless entry and start – standard on Automatic models
- Engine deadlock immobiliser
- Electronically protected audio equipment

ELITE



VX_COMV_31426

L1 PANEL VAN ON-THE-ROAD PRICES

EURO 6D TEMP (6.2)	OTR RRP exc. VAT	Insurance Group
Diesel		
2000 1.5 (100PS) Turbo D	£22,733.33	30E

L2 PANEL VAN ON-THE-ROAD PRICES

EURO 6D TEMP (6.2)		
Diesel		
2300 1.5 (100PS) Turbo D	£24,283.33	32E

Please note: On-the-road recommended retail prices (RRP) include number plates and delivery to Retailer of £583.33, 12 months' Vehicle Excise Duty (£265.00) and new vehicle first registration fee of £55.00. Excludes fuel and insurance.

FEATURES

Infotainment:

- Multimedia Navi Pro
 - Fully integrated European sat nav system
 - 8-inch colour touchscreen
 - Voice control
 - AM/FM/DAB digital radio
 - Bluetooth® audio streaming
 - Bluetooth® mobile phone portal
 - USB audio connection
 - Second USB charging connection
 - Four speakers
- Vauxhall Connect

Interior convenience/styling:

- Air conditioning
- Driver's top-lidded glovebox
- Six-way adjustable driver's seat with manual lumbar adjustment and armrest
- Full-width overhead storage shelf
- Electronic cruise control
- Steering wheel mounted audio controls
- Steering column adjustable for reach and rake
- Sight and Light Pack
- Vinyl load floor covering
- Surround rear vision
- FlexCargo
 - Dual front passengers' fixed bench seat
 - Fold-flat centre seat backrest with table
 - Two-way foldable outer seat
 - Load-through bulkhead
 - Electric parking brake

Exterior convenience/styling:

- Electrically adjustable/heated door mirrors
- Electrically operated front windows with one-touch facility
- Nearside sliding side-access door
- Black door mirrors
- Body-colour side-protection mouldings
- Body-colour door handles
- Body-colour sliding side-access door rail cover
- Body-colour front and rear bumpers
- Front fog lights
- Twin solid rear doors
- Metallic paint
- 16-inch alloy wheels
- Front and rear parking distance sensors
- Tyre pressure monitoring system

Safety/security:

- Driver's airbag
- Height-adjustable front lap and diagonal inertia-reel seatbelts
- Electronic stability programme with traction control
- Anti-lock braking system
- Daytime running lights
- Full-height steel bulkhead
- Hill start assist
- Remote control central deadlocking
- Remote control security alarm system
- Engine deadlock immobiliser
- Electronically protected audio equipment

CREW VAN



VX_COMV_28907

L2 CREW VAN EDITION ON-THE-ROAD PRICES

EURO 6D TEMP (6.2)	OTR RRP exc. VAT	Insurance Group
Diesel		
2300 1.5 (100PS) Turbo D	£21,558.33	30A

L2 CREW VAN SPORTIVE ON-THE-ROAD PRICES

EURO 6D TEMP (6.2)	OTR RRP exc. VAT	Insurance Group
Diesel		
2300 1.5 (100PS) Turbo D	£23,123.33	29E

Please note: On-the-road recommended retail prices (RRP) include number plates and delivery to Retailer of £583.33, 12 months' Vehicle Excise Duty (£265.00) and new vehicle first registration fee of £55.00. Excludes fuel and insurance.

The Combo Crew Van is classified as a Commercial Vehicle (Category N). It is not pre-approved for VAT reclaimable status and it is advisable that customers consult their local HMRC Office or visit www.hmrc.gov.uk for further details

FEATURES

Infotainment:

- AM/FM/DAB digital radio
- Bluetooth® audio streaming
- Bluetooth® mobile phone portal
- USB audio connection
- Four speakers
- Vauxhall Connect

Interior convenience/styling:

- Steering column adjustable for reach and rake
- Full-width overhead storage shelf
- Four-way adjustable driver's seat
- Four-way adjustable, folding front passenger's seat
- Three-seat second-row bench
- Vinyl load floor covering

Exterior convenience/styling:

- Electrically adjustable/heated door mirrors
- Electrically operated front windows with one-touch facility
- Nearside and offside sliding side-access doors
- Twin solid rear doors
- Emergency tyre inflation kit
- Side-protection mouldings
- 16-inch steel wheels with centre caps

Safety/security:

- Driver's airbag
- Height-adjustable front lap and diagonal inertia-reel seatbelts
- Rear lap and diagonal seatbelts
- Electronic stability programme with traction control
- Anti-lock braking system
- Two-position moveable ladder frame bulkhead
- Hill start assist
- Daytime running lights
- Remote control central deadlocking
- Engine deadlock immobiliser
- Electronically protected audio equipment

SPORTIVE MODELS ADDITIONALLY FEATURE

Infotainment:

- Multimedia audio system
- 8-inch colour touchscreen

Security:

- Remote control security alarm system

Interior convenience/styling:

- Steering wheel mounted audio controls
- Air conditioning
- Driver's top-lidded glovebox
- Height-adjustable driver's seat
- Manual lumbar adjustment
- Electronic cruise control

Exterior convenience/styling:

- Rear parking distance sensors
- Body-colour front and rear bumpers
- Metallic paint
- 16-inch steel wheels with full-diameter wheel trims

COMBO CARGO PANEL VAN PRICES/WEIGHTS

	Pack Code	Minimum Mass (kg)*	Maximum indicative payload (kg)*	Gross Vehicle Weights (GVW) (kg)	Plated weights (kg)		Towing weights (kg) Braked	Plated Gross Combination Weights (GCW) (kg)	Price (£) exc. VAT	On-the-road RRP (£) exc. VAT
					Front axle	Rear axle				
L1 EDITION PANEL VAN EURO 6D (6.3)										
2000 1.2 (110PS) S/S	DF05 EQ6W	1209	731	1940	1110	1075	1200	3140	17,630.00	18,533.33
L1 EDITION PANEL VAN EURO 6D TEMP (6.2)										
2000 1.5 (75PS) Turbo D	DF05 HF5W	1320	650	1970	1110	1075	1230	3200	17,580.00	18,483.33
2000 1.5 (100PS) Turbo D	DF05 HH5W	1320	665	1985	1200	1075	1350	3335	18,105.00	19,008.33
2300 1.5 (75PS) Turbo D	DF05 HF5Z	1320	1000	2320	1200	1400	880	3200	17,930.00	18,833.33
2300 1.5 (100PS) Turbo D	DF05 HH5Z	1347	998	2345	1200	1400	1000	3345	18,455.00	19,358.33
2300 1.5 (130PS) Turbo D S/S	DF05 HG6Z	1368	1002	2370	1200	1400	1200	3500	19,105.00	20,008.33
2300 1.5 (130PS) Turbo D S/S Automatic	DF05 HD8Z	1380	1000	2380	1200	1400	1000	3500	21,055.00	21,958.33
L1 DYNAMIC PANEL VAN EURO 6D TEMP (6.2)										
2000 1.5 (75PS) Turbo D	DF05 HF5Y	1320	650	1970	1110	1075	1230	3200	18,580.00	19,483.33
2300 1.5 (100PS) Turbo D	DF05 HH5Y	1320	1025	2345	1200	1400	1350	3500	19,455.00	20,358.33
2300 1.5 (75PS) Turbo D	DF05 HF5X	1320	1000	2320	1200	1400	880	3200	18,930.00	19,833.33
L1 SPORTIVE PANEL VAN EURO 6D TEMP (6.2)										
2000 1.5 (75PS) Turbo D	DL05 HF5W	1320	650	1970	1110	1075	1230	3200	19,655.00	20,558.33
2000 1.5 (100PS) Turbo D	DL05 HH5W	1320	665	1985	1200	1075	1350	3335	20,180.00	21,083.33
2300 1.5 (130PS) Turbo D S/S Automatic	DL05 HD8W	1380	1000	2380	1200	1400	1000	3380	22,570.00	23,473.33
2300 1.5 (100PS) Turbo D	DL05 HH5Z	1347	998	2345	1200	1400	1000	3345	20,530.00	21,433.33
2300 1.5 (130PS) Turbo D S/S	DL05 HG6Z	1347	998	2345	1200	1400	1000	3345	21,180.00	22,083.33

S/S = Start/Stop.

Please note: On-the-road recommended retail prices (RRP) include number plates and delivery to Retailer of £583.33, 12 months' Vehicle Excise Duty (£265.00) and new vehicle first registration fee of £55.00. Excludes fuel and insurance.

All Combo Vans include BlueInjection. Vehicles with BlueInjection technology will need regular AdBlue® top-ups also between servicing requirements. An indicator integrated into the on-board computer will warn you when you need to top up. More information under www.vauxhall.co.uk/adblue. In accordance with regulations R (EC) No. 715/2007 and R (EC) No. 692/2008 (in the versions respectively applicable).

Gross plated weights (including axle weights) quoted on the vehicle plate are to UK plated weight specification and must never be exceeded. Unbraked towing weight 600kg - all models.

*Minimum Mass for standard vehicles include coolant, oil and 90% full fuel tank. They will vary according to the vehicle specification (including trim, options and accessories) with a corresponding variation in payload.

COMBO CARGO PANEL VAN PRICES/WEIGHTS

	Pack Code	Minimum Mass (kg)*	Maximum indicative payload (kg)*	Gross Vehicle Weights (GVW) (kg)	Plated weights (kg)			Plated Gross Combination Weights (GCW) (kg)	Price (£) exc. VAT	On-the-road RRP (£) exc. VAT
					Front axle	Rear axle	Towing weights (kg) Braked			
L1 ELITE PANEL VAN EURO 6D TEMP (6.2)										
2000 1.5 (100PS) Turbo D	DL05 HH5Y	1320	665	1985	1200	1075	1350	3335	21,830.00	22,733.33
L2 EDITION PANEL VAN EURO 6D TEMP (6.2)										
2300 1.5 (100PS) Turbo D	DF05 HH51	1402	953	2355	1200	1400	1000	3355	19,655.00	20,558.33
2300 1.5 (130PS) Turbo D S/S Automatic	DF05 HD81	1430	950	2380	1200	1400	1000	3380	22,255.00	23,158.33
L2 DYNAMIC PANEL VAN EURO 6D TEMP (6.2)										
2300 1.5 (100PS) Turbo D	DF05 HH5X	1402	953	2355	1200	1400	1000	3355	20,655.00	21,558.33
L2 SPORTIVE PANEL VAN EURO 6D TEMP (6.2)										
2300 1.5 (100PS) Turbo D	DL05 HH51	1402	953	2355	1200	1400	1000	3355	21,730.00	22,633.33
L2 ELITE PANEL VAN EURO 6D TEMP (6.2)										
2300 1.5 (100PS) Turbo D	DL05 HH5X	1402	953	2355	1200	1400	1000	3355	23,380.00	24,283.33

S/S = Start/Stop.

Please note: On-the-road recommended retail prices (RRP) include number plates and delivery to Retailer of £583.33, 12 months' Vehicle Excise Duty (£265.00) and new vehicle first registration fee of £55.00. Excludes fuel and insurance.

All Combo Vans include BlueInjection. Vehicles with BlueInjection technology will need regular AdBlue® top-ups also between servicing requirements. An indicator integrated into the on-board computer will warn you when you need to top up. More information under www.vauxhall.co.uk/adblue. In accordance with regulations R (EC) No. 715/2007 and R (EC) No. 692/2008 (in the versions respectively applicable).

Gross plated weights (including axle weights) quoted on the vehicle plate are to UK plated weight specification and must never be exceeded. Unbraked towing weight 600kg – all models.

*Minimum Mass for standard vehicles include coolant, oil and 90% full fuel tank. They will vary according to the vehicle specification (including trim, options and accessories) with a corresponding variation in payload.

COMBO CARGO CREW VAN PRICES/WEIGHTS

	Pack Code	Minimum Mass (kg)*	Maximum indicative payload (kg)*	Gross Vehicle Weights (GVW) (kg)	Plated weights (kg)		Towing weights (kg) Braked	Plated Gross Combination Weights (GCW) (kg)	Price (£) exc. VAT	On-the-road RRP (£) exc. VAT
					Front axle	Rear axle				
L2 EDITION CREW VAN EURO 6D TEMP (6.2)										
2300 1.5 (100PS) Turbo D	DMC5 HH51	1475	900	2375	1200	1400	1050	3425	20,655.00	21,558.33
L2 SPORTIVE CREW VAN EURO 6D TEMP (6.2)										
2300 1.5 (100PS) Turbo D	DMC5 HH5X	1475	900	2375	1200	1400	1050	3425	22,220.00	23,123.33

Please note: On-the-road recommended retail prices (RRP) include number plates and delivery to Retailer of £583.33, 12 months' Vehicle Excise Duty (£265.00) and new vehicle first registration fee of £55.00. Excludes fuel and insurance.

VAT reclaimable status requires a minimum 1-tonne payload for Crew Vans in accordance with HMRC guidance. Crew Vans with a payload of less than 1-tonne may be eligible for VAT reclaimable status, subject to further HMRC assessment. Customers are advised to consult their local HMRC office or visit <https://www.gov.uk/government/organisations/hm-revenue-customs> for further details in relation to VAT reclaimable status. Payload calculations should take into consideration local UK Specification and Trim Level. Ordered options may also impact payload.

All Combo Vans include BlueInjection. Vehicles with BlueInjection technology will need regular AdBlue® top-ups also between servicing requirements. An indicator integrated into the on-board computer will warn you when you need to top up. More information under www.vauxhall.co.uk/adblue. In accordance with regulations R (EC) No. 715/2007 and R (EC) No. 692/2008 (in the versions respectively applicable).

Gross plated weights (including axle weights) quoted on the vehicle plate are to UK plated weight specification and must never be exceeded. Unbraked towing weight 600kg – all models.

*Minimum Mass for standard vehicles include coolant, oil and 90% full fuel tank. They will vary according to the vehicle specification (including trim, options and accessories) with a corresponding variation in payload.

COMBO CARGO 4X4 PRICES/WEIGHTS

	Pack Code	Minimum Mass (kg)*	Maximum indicative payload (kg)*	Gross Vehicle Weights (GVW) (kg)	Plated weights (kg)		Towing weights (kg) Braked	Plated Gross Combination Weights (GCW) (kg)	Price (£) exc. VAT	On-the-road RRP (£) exc. VAT
					Front axle	Rear axle				
L1 EDITION PANEL VAN EURO 6D TEMP (6.2)										
2300 1.5 (130PS) Turbo D S/S 4x4	DF05 HG6Y	1478	892	2370	1200	1400	1200	3500	35,260.00	36,163.33
L2 EDITION PANEL VAN EURO 6D TEMP (6.2)										
2300 1.5 (130PS) Turbo D S/S 4x4	DF05 HG6X	1532	848	2380	1200	1400	1200	3500	36,460.00	37,363.33

Combo 4x4

Combo 4x4 is an approved 3rd party conversion that is included in this guide for ease of ordering:

- Converter warranty is 3 years/60k miles and is equivalent to base vehicle
- Oil servicing transfer box/rear axle 16k miles or 2 years

For Aftersales/Warranty information

Contact: assistance@dangel.com or +33 3 89 38 98 89

The Dangel 4x4 system

The Dangel 4x4 system features 4x4 on demand via an On/Off mode selector (default on start-up is FWD). It adapts to varying roads and weather conditions and can easily change into two modes.

ECO 2WD mode: In this mode the 4x4 driveline is disengaged by a jaw clutch in the front transfer case. The vehicle works in FWD and this improves fuel economy and reduces tyre wear when 4x4 is not necessary.

AUTO 4WD mode: In conditions of normal surface grip, the vehicle works in standard FWD. If the front axle loses traction, the viscous-coupling unit transfers a part of the available torque to the rear axle. This intervention is automatic, smooth and only when necessary. The vehicle returns to FWD as soon as the front axle retains sufficient traction.

Advantages...

- 4X4 with viscous-coupling and ECO 2WD position
- Standard ground clearance 180mm (+90 mm with further increase available with 4x4 Plus Pack)
- Underbody protection for engine, gearbox and fuel tank
- Dangel 4x4 system adds just 110kg

S/S = Start/Stop.

Please note: On-the-road recommended retail prices (RRP) include number plates and delivery to Retailer of £583.33, 12 months' Vehicle Excise Duty (£265.00) and new vehicle first registration fee of £55.00. Excludes fuel and insurance.

All Combo Vans include BlueInjection. Vehicles with BlueInjection technology will need regular AdBlue® top-ups also between servicing requirements. An indicator integrated into the on-board computer will warn you when you need to top up. More information under www.vauxhall.co.uk/adblue. In accordance with regulations R (EC) No. 715/2007 and R (EC) No. 692/2008 (in the versions respectively applicable).

Gross plated weights (including axle weights) quoted on the vehicle plate are to UK plated weight specification and must never be exceeded. Unbraked towing weight 600kg – all models.

*Minimum Mass for standard vehicles include coolant, oil and 90% full fuel tank. They will vary according to the vehicle specification (including trim, options and accessories) with a corresponding variation in payload.

COMBO CARGO FUEL ECONOMY/EMISSIONS

	NEDC mpg (litres/100km) [#]		WLTP Fuel economy mpg (litres/100km) ^{##}			CO ₂ (g/km) ^{##}	
	Combined	CO ₂ (g/km) [#]	Combined Low	Combined High	High	Low	
L1 EDITION PANEL VAN EURO 6D (6.3)							
2000 1.2 (110PS) Turbo S/S	53.3 (5.3)	121	38.7 (7.3)	41.6 (6.8)	166	153	
L1 EDITION PANEL VAN EURO 6D TEMP (6.2)							
2000 1.5 (75PS) Turbo D	68.9 (4.1)	109	50.5 (5.6)	51.4 (5.5)	146	143	
2000 1.5 (100PS) Turbo D	70.6 (4.0)	106	51.4 (5.5)	53.3 (5.3)	144	138	
2300 1.5 (75PS) Turbo D	67.3 (4.2)	111	48.7 (5.8)	50.5 (5.6)	151	146	
2300 1.5 (100PS) Turbo D	68.9 (4.1)	108	47.1 (6.0)	51.4 (5.5)	158	143	
2300 1.5 (130PS) Turbo D S/S	62.8 (4.5)	117	51.4 (5.5)	47.9 (5.9)	155	145	
2300 1.5 (130PS) Turbo D S/S Automatic	65.7 (4.3)	114	45.6 (6.2)	48.7 (5.8)	162	151	
2300 1.5 (130PS) Turbo D S/S 4x4 (FWD default)	62.8 (4.5)	119	47.9 (5.9)	49.5 (5.7)	154	149	
2300 1.5 (130PS) Turbo D S/S 4x4 (four-wheel drive mode)	51.7 (5.5)	144	-	41.3 (6.8)	179	-	
L1 DYNAMIC PANEL VAN EURO 6D TEMP (6.2)							
2000 1.5 (75PS) Turbo D	68.9 (4.1)	111	50.5 (5.6)	51.4 (5.5)	146	144	
2000 1.5 (100PS) Turbo D	70.6 (4.0)	106	51.4 (5.5)	53.3 (5.3)	144	139	
2300 1.5 (75PS) Turbo D	68.9 (4.1)	109	48.7 (5.8)	50.5 (5.6)	151	146	

S/S = Start/Stop.

For fuel economy and CO₂ two sets of data are provided. All engines are validated to emissions standard Euro 6D Temp (6.2) which uses the newer WLTP cycle. This cycle is intended to be a closer representation to economy achieved in the real world and is included for this transparency. NEDC figures are not from the older cycle but in fact are a derived back-correlation calculation from the WLTP test data. Some systems and protocols such as the 2020 CO₂ target will use this figure, and hence it is included for this, and also to enable comparison to outgoing models.

[#]Fuel consumption and CO₂ emission data are determined using the Worldwide harmonised Light vehicles Test Procedure (WLTP), and the relevant values are translated back to allow the comparability into NEDC, according to regulations R (EC) No. 715/2007, R (EU) No. 2017/1153 and R (EU) No. 2017/1151. The values do not take into account in particular use and driving conditions, equipment or options and may vary depending on the format of tyres. For more information on official fuel consumption and CO₂ emission values, please read the guidelines at <http://vanfueldata.dft.gov.uk/>

^{##}Fuel consumption and CO₂ emission data are determined according to the WLTP test cycle. Full data relating to WLTP test cycles can be found at: www.vauxhall.co.uk/wltp

COMBO CARGO FUEL ECONOMY/EMISSIONS

	NEDC mpg (litres/100km) [#]		WLTP Fuel economy mpg (litres/100km) ^{##}			CO ₂ (g/km) ^{##}	
	Combined	CO ₂ (g/km) [#]	Combined Low	Combined High	High	Low	
L1 SPORTIVE PANEL VAN EURO 6D TEMP (6.2)							
2000 1.5 (75PS) Turbo D	68.9 (4.1)	109	50.5 (5.6)	51.4 (5.5)	146	144	
2000 1.5 (100PS) Turbo D	70.6 (4.0)	106	51.4 (5.5)	53.3 (5.3)	145	140	
2000 1.5 (130PS) Turbo D S/S Automatic	65.7 (4.3)	114	48.7 (5.8)	49.5 (5.7)	153	148	
2300 1.5 (100PS) Turbo D	68.9 (4.1)	108	49.5 (5.7)	51.4 (5.5)	150	145	
2300 1.5 (130PS) Turbo D S/S	62.8 (4.5)	118	49.5 (5.7)	50.5 (5.6)	150	146	
L1 ELITE PANEL VAN EURO 6D TEMP (6.2)							
2000 1.5 (100PS) Turbo D	70.6 (4.0)	106	51.4 (5.5)	53.3 (5.3)	145	140	

S/S = Start/Stop.

For fuel economy and CO₂ two sets of data are provided. All engines are validated to emissions standard Euro 6D Temp (6.2) which uses the newer WLTP cycle. This cycle is intended to be a closer representation to economy achieved in the real world and is included for this transparency. NEDC figures are not from the older cycle but in fact are a derived back-correlation calculation from the WLTP test data. Some systems and protocols such as the 2020 CO₂ target will use this figure, and hence it is included for this, and also to enable comparison to outgoing models.

[#]Fuel consumption and CO₂ emission data are determined using the Worldwide harmonised Light vehicles Test Procedure (WLTP), and the relevant values are translated back to allow the comparability into NEDC, according to regulations R (EC) No. 715/2007, R (EU) No. 2017/1153 and R (EU) No. 2017/1151. The values do not take into account in particular use and driving conditions, equipment or options and may vary depending on the format of tyres. For more information on official fuel consumption and CO₂ emission values, please read the guidelines at <http://vanfueldata.dft.gov.uk/>

^{##}Fuel consumption and CO₂ emission data are determined according to the WLTP test cycle. Full data relating to WLTP test cycles can be found at: www.vauxhall.co.uk/wltp

COMBO CARGO FUEL ECONOMY/EMISSIONS

	NEDC mpg (litres/100km) [#]		WLTP Fuel economy mpg (litres/100km) ^{##}			CO ₂ (g/km) ^{##}	
	Combined	CO ₂ (g/km) [#]	Combined Low	Combined High	High	Low	
L2 EDITION PANEL VAN EURO 6D TEMP (6.2)							
2300 1.5 (100PS) Turbo D	68.9 (4.1)	108	47.1 (6.0)	51.4 (5.5)	158	144	
2300 1.5 (130PS) Turbo D S/S Automatic	65.7 (4.3)	114	45.6 (6.2)	48.7 (5.8)	162	151	
2300 1.5 (130PS) Turbo D S/S 4x4 (FWD default)	62.8 (4.5)	119	47.9 (5.9)	49.5 (5.7)	155	150	
2300 1.5 (130PS) Turbo D S/S 4x4 (four-wheel drive mode)	51.7 (5.5)	144	-	41.3 (6.8)	179	-	
L2 DYNAMIC PANEL VAN EURO 6D TEMP (6.2)							
2300 1.5 (100PS) Turbo D	68.9 (4.1)	108	47.1 (6.0)	51.4 (5.5)	158	145	
L2 SPORTIVE PANEL VAN EURO 6D TEMP (6.2)							
2300 1.5 (100PS) Turbo D	68.9 (4.1)	108	48.7 (5.8)	50.5 (5.6)	152	147	
L2 ELITE PANEL VAN EURO 6D TEMP (6.2)							
2300 1.5 (100PS) Turbo D	68.9 (4.1)	108	48.7 (5.8)	50.5 (5.6)	152	148	
L2 EDITION CREW VAN EURO 6D TEMP (6.2)							
2300 1.5 (100PS) Turbo D	67.3 (4.2)	111	49.5 (5.7)	50.5 (5.6)	150	148	
L2 SPORTIVE CREW VAN EURO 6D TEMP (6.2)							
2300 1.5 (100PS) Turbo D	67.3 (4.2)	111	49.5 (5.7)	49.5 (5.7)	150	148	

S/S = Start/Stop.

For fuel economy and CO₂ two sets of data are provided. All engines are validated to emissions standard Euro 6D Temp (6.2) which uses the newer WLTP cycle. This cycle is intended to be a closer representation to economy achieved in the real world and is included for this transparency. NEDC figures are not from the older cycle but in fact are a derived back-correlation calculation from the WLTP test data. Some systems and protocols such as the 2020 CO₂ target will use this figure, and hence it is included for this, and also to enable comparison to outgoing models.

[#]Fuel consumption and CO₂ emission data are determined using the Worldwide harmonised Light vehicles Test Procedure (WLTP), and the relevant values are translated back to allow the comparability into NEDC, according to regulations R (EC) No. 715/2007, R (EU) No. 2017/1153 and R (EU) No. 2017/1151. The values do not take into account in particular use and driving conditions, equipment or options and may vary depending on the format of tyres. For more information on official fuel consumption and CO₂ emission values, please read the guidelines at <http://vanfueldata.dft.gov.uk/>

^{##}Fuel consumption and CO₂ emission data are determined according to the WLTP test cycle. Full data relating to WLTP test cycles can be found at: www.vauxhall.co.uk/wltp

FEATURES/OPTIONS

DRIVER ASSISTANCE

	Option code	Edition	Dynamic	Sportive	Elite	Price (£) exc. VAT	Price (£) inc. VAT
Parking brake		●	●	●			
• Floor-mounted handbrake lever – Sportive automatic models only.							
• Electronic parking brake – Standard on Sportive manual models only.				●	●		
Electronic cruise control with speed limiter	K33	○	●	●	●	150.00	180.00
Adaptive Cruise Control with speed limiter and intelligent speed adaptation	K38			○		250.00	300.00
– 1.5 (130PS) diesel manual models. Only available in conjunction with Safety Pack.							
Parking sensors	UD7	○	●	●	●	200.00	240.00
• Rear parking distance sensors • Audible warning							
• Front and rear parking distance sensors – Not available on Crew Van.	UD5		○	○	●	400.00	480.00
Surround rear vision – Only available in conjunction with front fog lights and front/rear parking distance sensors. Permanent display through digital rear-view mirror with three functions:							
• Side passenger view – Enables passenger side blind spot to be seen • Rear-view monitoring – Provides an image from the rear and effectively replaces rear-view mirror • Visual aid for reversing – Displays area to the rear of the vehicle when in reverse gear and indicates the width of the vehicle with the rear-view mirrors extended	UL3		○	○	●	500.00	600.00
Rear-view camera for park assistance	UVC	○	○	○		250.00	300.00
Display appears in rear-view mirror with standard radio, or in multimedia display in combination with Multimedia system (iO5) or Multimedia Navi Pro system (iO6) – Only available with front fog lights and rear, or front/rear parking distance sensors. Not available on Crew Van							
Sight and Light Pack							
• High beam assist • Rain-sensitive windscreen wipers • 3.5-inch colour information display – Includes driver drowsiness indicator. • Automatic anti-dazzle rear-view mirror – Included when glazed rear doors are ordered. Standard on Automatic models.	CWX			○	●	175.00	210.00

● = Standard equipment. ○ = Optional at extra cost.

FEATURES/OPTIONS

DRIVER ASSISTANCE CONTINUED

	Option code	Edition	Dynamic	Sportive	Elite	Price (£) exc. VAT	Price (£) inc. VAT
Head-up display • Navigation directions • Speedometer • Rev counter • Set speed of cruise control and speed limiter • Forward collision alert	UV6			○	○	300.00	360.00
Construction Pack with IntelliGrip Improved protection and grip with engine sump guard/shield and Michelin Latitude Tour Mud and Snow tyres. IntelliGrip traction control is designed to increase grip in difficult conditions without the additional weight of a conventional four-wheel drive system. It's an innovative grip control system that provides improved traction on certain terrain and conditions through a combination of optimised torque distribution and limited wheel spin, managed through the electronic stability programme. • Underride protection • 215/65 R16 tyres • Increased chassis height (+30mm) • IntelliGrip: A choice of five selectable modes to suit the driving conditions: ESP on, ESP off, snow, mud, sand – Not available on 4x4 models.	HMG (includes PS4)	○	○			930.00	1,116.00

○ = Optional at extra cost.

FEATURES/OPTIONS

SAFETY

	Option code	Edition	Dynamic	Sportive	Elite	Price (£) exc. VAT	Price (£) inc. VAT
Driver/passenger airbags • Driver's airbag		●	●	●	●		
• Driver and front passenger's airbag – Standard on Automatic models.	AK5	○	○	○	○	120.00	144.00
• Driver and front passenger's side-impact airbags – Only available on Edition Crew Van models.	AJ7		○	○	○	390.00	468.00
• Driver and front passenger's side-impact and curtain airbags – Not available on Crew Van.	AKB		○	○	○	490.00	588.00
Seatbelts • Height-adjustable lap and diagonal inertia-reel front seatbelts • Three lap and diagonal inertia-reel rear seatbelts (Crew Van) • Front body-lock diagonal seatbelt pretensioner system – Tightens the seatbelt during the early stages of a frontal impact. • Drivers and front passenger's lap belt pretensioner system • Front seatbelt force limiters – Reduces potential upper body injuries during a frontal impact. • Anti-submarining ramps in front seats – Help prevent occupants sliding underneath the lap belt during a collision.		●	●	●	●		
Child safety • Deactivation switch for front passenger's front and side-impact airbags (when specified) – Permits the safe use of a child seat in the front passenger seat.		□	□	□	□		
Driver/passenger safety • Energy-absorbing steering column • Side-impact protection beams • Reinforced passenger safety cell • Deformation zones front and rear		●	●	●	●		
Braking and stability • Electronic stability programme • Anti-lock braking system • Corner stability control • Traction control • Hill start assist • Engine drag torque control – Improves directional stability by preventing the driven wheels from locking on slippery surfaces under the influence of engine braking. • Emergency brake assist • Electronic brakeforce distribution		●	●	●	●		
Tyre pressure • Deflation detection system – Not available on 4x4.	UJO	○	○	○	●	185.00	222.00
Overload indicator Prevents risk of overloading. Avoids risk of a fine for exceeding the load limit. – Not available on 4x4 or Crew Van models.	J89	○	○	○	○	260.00	312.00

● = Standard equipment. ○ = Optional at extra cost. □ = Only available when passenger's airbag options are specified.

FEATURES/OPTIONS

SAFETY CONTINUED

	Option code	Edition	Dynamic	Sportive	Elite	Price (£) exc. VAT	Price (£) inc. VAT
Bulkhead <ul style="list-style-type: none"> • Full-height steel bulkhead – Sportive and Elite models include load-through facility. 		●	●	●	●		
<ul style="list-style-type: none"> • Full-height steel bulkhead with window – Panel Van. 	AX9	○	○			175.00	210.00
<ul style="list-style-type: none"> • Two-position moveable ladder frame bulkhead – Crew Van. 		●		●			
Safety Pack – Standard on Automatic models. Includes leather-covered steering wheel. Requires electronic cruise control or adaptive cruise control with speed limiter and intelligent speed adaptation. Not available on 4x4 models.							
Front camera system A range of class-leading driver assistance and safety features are controlled by the front camera system.							
Lane keep assist with lane departure warning If the driver has not actively steered or signalled, the lane departure warning system provides gentle steering correction and warns when the vehicle moves outside of lane markings at speeds above 40mph. • Warning light in instrument cluster • Audible warning • Facia on/off switch							
Speed sign recognition Detects and then displays speed limits, reducing uncertainty and the risk of speeding.	B26	○	○	○	○	724.50	805.00
Driver drowsiness system The system monitors driving time and driving behaviour to help prevent accidents caused by tiredness.							
Forward collision alert The system operates Automatically from 3mph and gives an audible warning as well as a visual warning when approaching another vehicle too quickly.							
Automatic emergency braking with pedestrian detection The system works Automatically in conjunction with forward collision alert, at speeds between 3mph and 70mph, and detects both vehicles and pedestrians. If no avoiding action is taken by the driver, at speeds below 19mph the system Automatically slows the vehicle to a full stop with emergency braking of 0.9g. At speeds from 19mph to 70mph it brakes Automatically to reduce speed by a maximum of 30mph – to reduce speed even further the driver must brake him/herself. The operational speed range of the system depends on the detected obstacle (mobile target: from 3 to 53mph; fixed target: from 3 to 70mph; pedestrian: from 3 to 37mph). Vauxhall driver assistance systems are intended to support the driver within the system-imminent limitations. The driver remains responsible for the driving task.							

● = Standard equipment. ○ = Optional at extra cost.

FEATURES/OPTIONS

SECURITY

	Option code	Edition	Dynamic	Sportive	Elite	Price (£) exc. VAT	Price (£) inc. VAT
Standard security features <ul style="list-style-type: none"> • Electronically protected audio equipment • Engine deadlock immobiliser • Visible Vehicle Identification Number (VIN) • Locking wheel bolts for alloy wheels (where fitted) 		●	●	●	●		
Remote control central locking <ul style="list-style-type: none"> • Operates on all doors and fuel filler flap • Deadlocking • Driver's internal central locking activation switch • Two folding keys, each with integral remote control function 		●	●	●	●		
Remote control security alarm system <ul style="list-style-type: none"> • Remote control – Operates in conjunction with central locking. • Bonnet protection – Prevents access to the engine bay. • Visible security LED on fascia • Load area protection – Monitors the load compartment preventing access. • Door protection – Monitors the position of all doors. • Ultrasonic intrusion sensor • Power alarm sounder • Vehicle theft attempt and diagnostic indication – Shows in the display any attempt to enter or steal the vehicle during driver absence. 	PS6	○	●	●	●	150.00	180.00

● = Standard equipment. ○ = Optional at extra cost.

FEATURES/OPTIONS

DRIVER INFORMATION

	Option code	Edition	Dynamic	Sportive	Elite	Price (£) exc. VAT	Price (£) inc. VAT
Instrumentation <ul style="list-style-type: none"> • Speedometer • Rev counter • Fuel gauge with low fuel level warning light • Water temperature gauge with warning light • Shift-up indication light (manual models only) – Indicates when to change gear for optimum fuel economy. 		●	●	●	●		
Driver information display Centrally located in instrument cluster. <ul style="list-style-type: none"> • Displays trip computer data • Total mileage • Service-due indicator 		●	●	●	●		
Multi-function trip computer Displayed on driver information display. <ul style="list-style-type: none"> • Trip mileage • Vehicle range based on remaining fuel • Average speed • Average fuel economy • Instantaneous fuel economy 		●	●	●	●		
Central facia display Format dependent on infotainment unit. <ul style="list-style-type: none"> • Audio information • Digital clock with Automatic RDS time adjustment • Outside air temperature with ice warning function • Additional features dependent on infotainment unit – See infotainment for details. 		●	●	●	●		

● = Standard equipment.

FEATURES/OPTIONS

SEATING AND COMFORT

	Option code	Edition	Dynamic	Sportive	Elite	Price (£) exc. VAT	Price (£) inc. VAT
Adjustable steering column • Reach and rake-adjustable steering column		●	●	●	●		
Driver's seat 4-way adjustable. • Reach • Backrest recline		●					
Driver's seat 6-way adjustable. • Height • Reach • Manual lumbar adjustment • Armrest	A2V	○	●	●	●	125.00	150.00
Front passenger's seat • Fixed • Underseat storage		●					
Front passenger's seat – Sportive automatic models only. 4-way adjustable. • Reach • Backrest recline • Manual lumbar adjustment			●	●			
Front passenger's seat – Sportive manual models only. • Dual front passengers' fixed bench seat • Fold-flat centre seat backrest with table • Two-way foldable outer seat				●	●		
Front passenger's seat – Crew Van models. 4-way adjustable and foldable. • Reach • Backrest recline • Armrest		●		●			
Second-row – Crew Van models. • Three-person layout • 60/40 split-folding rear seat • Fold and tumble facility • Height-adjustable and removable head restraints		●		●			
Seat trim • Mistral Grey with Curitiba fabric seat trim inserts		●	●	●	●		

● = Standard equipment. ○ = Optional at extra cost.

FEATURES/OPTIONS

SEATING AND COMFORT CONTINUED

	Option code	Edition	Dynamic	Sportive	Elite	Price (£) exc. VAT	Price (£) inc. VAT
FlexCargo Pack <hr/> Panel Van. • Dual front passengers' fixed bench seat • Fold-flat centre seat backrest with table • Two-way foldable outer seat • Load-through bulkhead • Electric parking brake • 'Seatbelt unfastened' audible warning and warning light – Manual models only. Includes 6-way adjustable driver's seat on Edition models.	AYW	○	○	●	●	612.00	734.44
FlexCargo Glazed Pack <hr/> Panel Van. • Dual front passengers' fixed bench seat • Fold-flat centre seat backrest with table • Two-way foldable outer seat • Load-through glazed bulkhead • Electric parking brake • 'Seatbelt unfastened' audible warning and warning light – Manual models only. Available only when glazed rear door option is specified. Includes 6-way adjustable driver's seat on Edition models.	AYV	○	○	○	○	690.00 72.00	828.00 80.00

FEATURES/OPTIONS

HEATING AND VENTILATION

	Option code	Edition	Dynamic	Sportive	Elite	Price (£) exc. VAT	Price (£) inc. VAT
Cab heating <ul style="list-style-type: none"> • Six-speed fan • Illuminated controls • Four adjustable facia vents • Windscreen demist vents • Side window demist vents 		●	●	●	●		
Air conditioning <ul style="list-style-type: none"> • Air recirculation facility • Cabin particulate filter – Removes dust, airborne particles and pollen. 	C60	○	●	●	●	600.00	720.00
Electronic climate control including air conditioning <ul style="list-style-type: none"> • Dual-zone control – allowing different temperature settings for driver and front passenger. • Advanced predictive logic control system using sun sensors • Partial air recirculation – faster warm up/cool down. • Cabin particulate filter – removes dust, airborne particles and pollen. • Automatic air direction and fan speed with manual override • LCD temperature display • Illuminated controls – Only available when the Sight and Light Pack is specified. 	CJ2			○	○	200.00	240.00

INTERIOR CONVENIENCE AND STORAGE

Mirrors <ul style="list-style-type: none"> • Dipping rear-view mirror – When glazed bulkhead and rear doors are specified. • Driver's and front passenger's sunvisors • Vanity mirror on rear of driver's sunvisor 		●	●	●	●		
Front compartments <ul style="list-style-type: none"> • Two facia-mounted drinks holders • Two drinks holders in centre console • Large open storage pocket behind infotainment screen • Small open storage compartment behind gear lever • Two large and two small open door pockets • Open storage compartment below glovebox • Full-width overhead storage shelf with ambient lighting 		●	●	●	●		

● = Standard equipment. ○ = Optional at extra cost.

FEATURES/OPTIONS

LOAD AREA

	Option code	Edition	Dynamic	Sportive	Elite	Price (£) exc. VAT	Price (£) inc. VAT
Load floor covering – Panel Van only. • Plywood load floor covering	CRJ	○	○	○	○	180.00	216.00
• Vinyl load floor covering – Standard on Crew Van models.	CRK	○	○	○	●	60.00	72.00
Illuminated load area		●	●	●	●		
Fixed floor-mounted load restraint lashing eyes – Six.		●	●	●	●		
LED illuminated load area – Panel Van only.	8G8	○	○	○	○	200.00	240.00
Side access – Unglazed. • Nearside sliding side-access door – L1 models.		●	●	●	●		
• Nearside and offside sliding side-access doors – Standard on L2 and Crew Van models.	CVM	○	○	○	○	220.00	264.00
Side access – Glazed. Panel Van only. • Fixed window in nearside sliding side-access door • Fixed window in opposite panel – L1 models.	BSB	○	○	○	○	320.00	384.00
Side access – Glazed. Panel Van only. • Offside sliding side-access door • Fixed window in nearside sliding side-access door • Fixed window in offside sliding side-access door – L1 models.	BSA	○	○	○	○	540.00	648.00
Side access – Glazed. Panel Van only. • Fixed window in nearside sliding side-access door • Fixed window in offside sliding side-access door – L2 models.	BSB	○	○	○	○	320.00	384.00
Rear access – Unglazed. • Twin solid rear doors		●	●	●	●		
Rear access – Glazed. • Twin glazed rear doors – Only available with glazed bulkhead options.	J1X	○	○	○	○	160.00	192.00

● = Standard equipment. ○ = Optional at extra cost.

FEATURES/OPTIONS

INFOTAINMENT

	Option code	Edition	Dynamic	Sportive	Elite	Price (£) exc. VAT	Price (£) inc. VAT
<p>Radio</p> <p>Onboard features:</p> <ul style="list-style-type: none"> • AM/FM stereo radio • DAB Digital radio • RDS with Traffic Programme • 20 watts per channel output • Four speakers <p>Media connections:</p> <ul style="list-style-type: none"> • USB connection with iPod control • Bluetooth® A2DP audio streaming (Advanced Audio Distribution Profile) <p>Mobile phone portal:</p> <ul style="list-style-type: none"> • Bluetooth® connectivity • Handsfree calls via steering wheel controls • Vehicle microphone 		●	●				
<p>Multimedia</p> <p>Onboard features:</p> <ul style="list-style-type: none"> • 8-inch colour touchscreen • AM/FM stereo radio with 25 station presets • DAB Digital radio • RDS with Traffic Programme • 20 watts per channel output • Four speakers <p>Media connections:</p> <ul style="list-style-type: none"> • USB connection with iPod control • Bluetooth® A2DP audio streaming (Advanced Audio Distribution Profile) <p>Mobile phone portal:</p> <ul style="list-style-type: none"> • Bluetooth® connectivity • Handsfree calls via steering wheel controls • Vehicle microphone • Phone book access – Contacts/last calls/missed calls etc. are mirrored on the display and are easily navigated using the touchscreen (features dependent on mobile phone). <p>Smartphone interface:</p> <ul style="list-style-type: none"> • Apple CarPlay™ • Android Auto™ – Smartphone projection that allows operations via voice command, touchscreen and buttons to control apps and music playback. 	i05	○	○	●		400.00	480.00

● = Standard equipment. ○ = Optional at extra cost.

FEATURES/OPTIONS

INFOTAINMENT CONTINUED

	Option code	Edition	Dynamic	Sportive	Elite	Price (£) exc. VAT	Price (£) inc. VAT
<p>Multimedia Navi Pro – Requires electronic cruise control or adaptive cruise control with speed limiter and intelligent speed adaptation.</p> <p>Onboard features:</p> <ul style="list-style-type: none"> • 8-inch colour touchscreen • AM/FM stereo radio with 25 station presets • DAB Digital radio • RDS with Traffic Programme • 20 watts per channel output • Four speakers <p>Navigation features:</p> <ul style="list-style-type: none"> • Satellite navigation system • 3D street level mapping • European coverage • Structured or one-box destination entry • Points-of-interest search • Eco routing • Map updates via USB <p>Media connections:</p> <ul style="list-style-type: none"> • USB connection with iPod control • Bluetooth® A2DP audio streaming (Advanced Audio Distribution Profile) <p>Mobile phone portal:</p> <ul style="list-style-type: none"> • Bluetooth® connectivity • Handsfree calls via steering wheel controls • Vehicle microphone • Phone book access – Contacts/last calls/missed calls etc. are mirrored on the display and are easily navigated using the touchscreen (features dependent on mobile phone). <p>Smartphone interface:</p> <ul style="list-style-type: none"> • Apple CarPlay™ • Android Auto™ – Smartphone projection that allows operations via voice command, touchscreen and buttons to control apps and music playback. 	IO6	○	○	○	●	750.00 350.00	900.00 420.00
<p>Steering wheel mounted audio controls</p> <p>– Standard on Automatic Edition models.</p>			●	●	●		
<ul style="list-style-type: none"> • 12-volt electrical accessory socket – Centre console. • 12-volt electrical accessory socket – Passenger side. • USB charging point in glovebox • USB charging/infotainment points – Infotainment unit and rear of centre console. 		●	●	●	●		
<p>230-volt electrical accessory socket – In lieu of passenger side 12-volt electrical accessory socket.</p>	KI5			○	○	100.00	120.00
<p>Wireless charger for mobile devices – Inductive wireless charging facility in lower fascia.</p>	K4C			○	○	80.00	96.00
<p>Vauxhall Connect</p>		●	●	●	●		

● = Standard equipment. ○ = Optional at extra cost.



FEATURES/OPTIONS

EXTERIOR STYLING AND CONVENIENCE

	Option code	Edition	Dynamic	Sportive	Elite	Price (£) exc. VAT	Price (£) inc. VAT
Body styling • Nearside sliding side-access door • Twin solid rear doors • Side-protection mouldings		●	●	●	●		
• Body-colour front and rear bumpers				●	●		
• Body-colour side-protection mouldings • Body-colour door handles • Body-colour sliding side-access door rail cover					●		
Windscreen/windows • Solar heat-absorbing windscreen • Two-speed windscreen wipers with variable intermittent wipe • Electrically operated front windows with safety autoreverse and one-touch facility • Tinted windows		●	●	●	●		
Door mirrors • Twin electrically adjustable/heated door mirrors • Manually folding door mirrors		●	●	●	●		
Front fog lights	T3U	○	○	●	●	125.00	150.00
Tow bar – Not available on 4x4 models.	VTO	○	○	○	○	210.00	252.00
Roof rails	E2R			○	○	125.00	150.00
4x4 Plus Pack (4x4 models only) • Rear differential locking • Increased ride height +20 mm (Indicative 205mm ground clearance) • Tyres – Mud & Snow (3PMSF) 215/65 R 16.	XZSW	○				3,166.67	3,800.00

● = Standard equipment. ○ = Optional at extra cost.

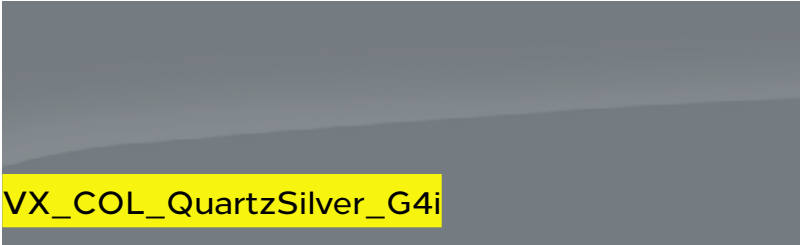

EXTERIOR COLOURS

				Edition	Dynamic	Sportive	Elite	Price (£) exc. VAT	Price (£) inc. VAT	
Solid	 VX_COL_OnyxBlack_G7R	Onyx Black (G7R)	 VX_COL_White_Jade_G2o	Jade White (G2O)	●	●	●	●		
Two-coat	 VX_COL_MoonstoneGrey_G4o	Moonstone Grey metallic (G4O)	 VX_COL_QuartzSilver_G4i	Quartz Silver metallic (G4I)	○	○	N/C	N/C	475.00	570.00

The colours reproduced may vary slightly from the actual paint colour. As a result they should be used as a guide only. Your Vauxhall Retailer has a comprehensive display of our paint samples.

● = Standard equipment. ○ = Optional at extra cost. N/C = No-cost option.

COMBO CARGO WHEELS AND TYRES

	Option code	Edition	Dynamic	Sportive	Elite	Price (£) exc. VAT	Price (£) inc. VAT
15-inch steel spare wheel • 185/65 R 15 tyres • In lieu of emergency tyre inflation kit (2000 models)	RU3	N/C	N/C			No-cost option	
16-inch steel spare wheel • 205/60 R 16 tyres • In lieu of emergency tyre inflation kit (2300/Sportive/Elite models)	RU9	N/C	N/C	N/C	N/C	No-cost option	
 <p>15-inch steel wheels with centre caps (2000 models)</p> <ul style="list-style-type: none"> • 185/65 R 15 tyres • Emergency tyre inflation kit (in lieu of spare wheel) <p>16-inch steel wheels with centre caps (2300 models)</p> <ul style="list-style-type: none"> • 205/60 R 16 tyres • Emergency tyre inflation kit (in lieu of spare wheel) 		●	●				
 <p>16-inch steel wheels with full-diameter wheel trims (2300 models)</p> <ul style="list-style-type: none"> • 205/60 R 16 tyres • Emergency tyre inflation kit (in lieu of spare wheel) 				●			
 <p>16-inch alloy wheels</p> <ul style="list-style-type: none"> • 205/60 R 16 tyres • Emergency tyre inflation kit (in lieu of spare wheel) 					●		

● = Standard equipment. N/C = No-cost option.

COMBO CARGO 4X4 WHEELS AND TYRES

	Option code	Edition	Sportive	Price (£) exc. VAT	Price (£) inc. VAT
 <p>16-inch steel wheels with centre caps</p> <ul style="list-style-type: none">• 215/65 R 16 worksite tyres• Emergency tyre inflation kit (in lieu of spare wheel) <p>VX_COM_28907</p>		●			

● = Standard equipment.

SPECIFICATIONS

Transmission

- Front-wheel drive
- Five-speed manual gearbox 1.5 (75/100PS) Turbo D models
- Six-speed manual gearbox – 1.5 (130PS) Turbo D/1.2 (110PS) Turbo models
- Eight-speed Automatic transmission – available on 1.5 (130PS) Turbo D models

Replacing the traditional lever, the Automatic transmission selection-mode dial/drive wheel is an innovative solution that is both elegant and intuitive. By simply twisting the dial, the following modes can be selected:

- Park, for when the vehicle is stationary and the wheels are locked
- Drive, for Automatic forward motion
- Neutral, for when the vehicle is stationary, wheels are free
- Reverse, for Automatic backward motion

For an extra experience of dynamism, the shift paddles for Automatic transmissions are located behind the steering wheel, offering drivers an extra level of control that is highly ergonomic and intuitive. The shift paddles function in the following way:

- To go up a gear, the driver must pull the right lever towards themselves
- To go down a gear, the driver must pull the left lever towards themselves*

Steering

- Speed-sensitive electric power-assisted system
- Turning circle (kerb-to-kerb) – 11.0m (36 ft) L1 models, 11.8m (38.7 ft) L2 models

Suspension

Front: Independent. MacPherson struts with gas-pressure dampers and linear-rate coil springs. Anti-roll bar

Rear: Torsion beam with gas-pressure dampers and constant-rate coil springs (variable-rate on 2300 models)

Roof Loads

- Combo roof load should not exceed 100kg including the weight of the roof rack/carrier

Fuel Tank Capacity

- 61 litres (13.0 gallons) – Petrol models
- 50 litres (10.9 gallons) – Diesel models

AdBlue® Tank Capacity

- 17 Litres (3.7 gallons)

PETROL ENGINE

Engine	1.2 (110PS) Turbo Start/Stop
Capacity	1199cc
Maximum power	110PS (81kW) @ 5500rpm
Maximum torque	205Nm (151 lb.ft.) @ 1750rpm
Configuration	3 cylinders, 4 valves per cylinder, double overhead camshafts
Fuel/induction system	Turbocharger. Variable Valve Timing. Direct fuel injection
Emission compliance	Euro 6D
Service interval	12,500 miles or 1 year (whichever occurs sooner)

DIESEL ENGINES

Engine	1.5 (75PS) Turbo D BlueInjection	1.5 (100PS) Turbo D BlueInjection	1.5 (130PS) Turbo D Start/Stop BlueInjection
Capacity	1499cc	1499cc	1499cc
Maximum power	75PS (55kW) @ 3500rpm	100PS (75kW) @ 3500rpm	130PS (96kW) @ 3750rpm
Maximum torque	230Nm (170 lb.ft.) @ 1750rpm	250Nm (184 lb.ft.) @ 1750rpm	300Nm (221 lb.ft.) @ 1750rpm
Configuration	4 cylinders, 4 valves per cylinder, double overhead camshafts	4 cylinders, 4 valves per cylinder, double overhead camshafts	4 cylinders, 4 valves per cylinder, double overhead camshafts
Fuel/induction system	Turbocharger with intercooler. Common rail fuel injection	Variable-nozzle turbocharger with electric switching. Common rail direct injection	Variable-nozzle turbocharger with electric switching. Common rail direct injection
Emission compliance	Euro 6d-TEMP with Diesel Particulate Filter	Euro 6d-TEMP with Diesel Particulate Filter	Euro 6d-TEMP with Diesel Particulate Filter
Service interval	25,000 miles or 2 years (whichever occurs sooner)	25,000 miles or 2 years (whichever occurs sooner)	25,000 miles or 2 years (whichever occurs sooner)

DIMENSIONS

Loadspace Dimensions	Panel Van		Crew Van
	L1	L2	L2
Load length	1527 (60.1) – 1817 (71.5)	1877 (73.9) – 2167 (85.3)	1051 (41.4) – 2110 (83.1)
Load length – With ‘load through’	3090 (121.7)	3440 (135.4)	3050 (120.1)
Maximum load height	1236 (48.7)	1243 (48.9)	1243 (48.9)
Load width – With nearside side-access door	1630 (64.2)	-	-
Load width – With nearside and offside side-access doors	1527 (60.1)	1527 (60.1)	1527 (60.1)
Maximum width between wheel arches	1229 (48.4)	1229 (48.4)	1229 (48.4)
Loading height	548 (21.6) – 610 (24.0)	548 (21.6) – 610 (24.0)	620 (24.4)
Maximum rear door aperture width	1241 (48.9)	1241 (48.9)	1241 (48.9)
Maximum rear door aperture height	1196 (47.1)	1196 (47.1)	1196 (47.1)
Maximum side-access aperture width	675 (26.6)	675 (26.6)	759 (29.9)
Maximum side-access aperture height	1072 (42.2)	1072 (42.2)	1072 (42.2)
Loadspace Volumes cu.m (cu.ft.)			
Panel Van	3.3 (116.5)	3.9 (137.7)	-
Panel Van – With ‘load through’	3.8 (134.2)	4.4 (155.4)	-
Crew Van – With seats folded	-	-	4.0 (141.2)
Crew Van – With seats up (to top of seats)	-	-	1.8 (63.6)
Crew Van – With seats up (to roof)	-	-	3.5 (123.6)

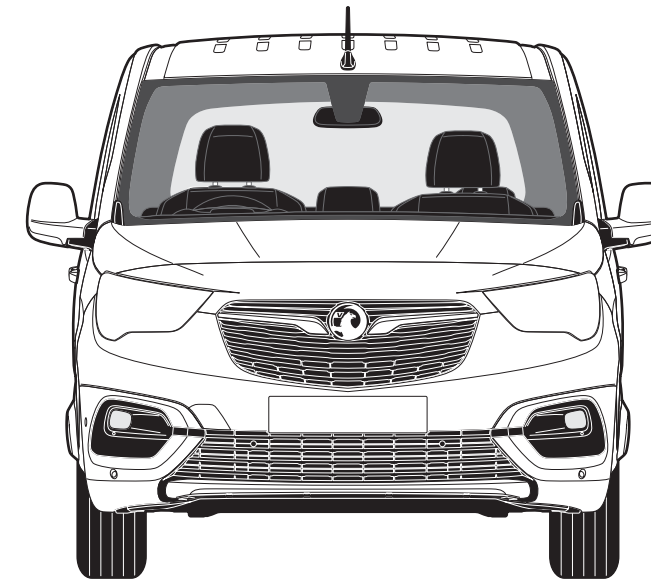

1848 (72.7) excluding door mirrors
2107 (83.0) including door mirrors

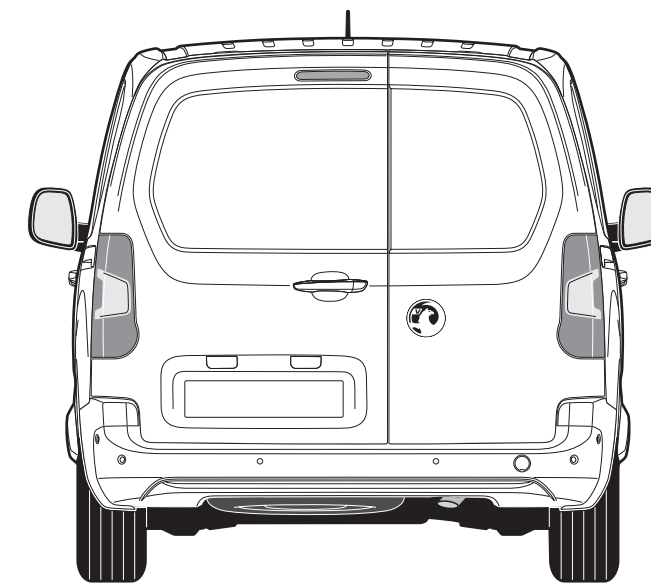

1848 (72.7) excluding door mirrors
2107 (83.0) including door mirrors

1796-1860 (70.7-73.2)

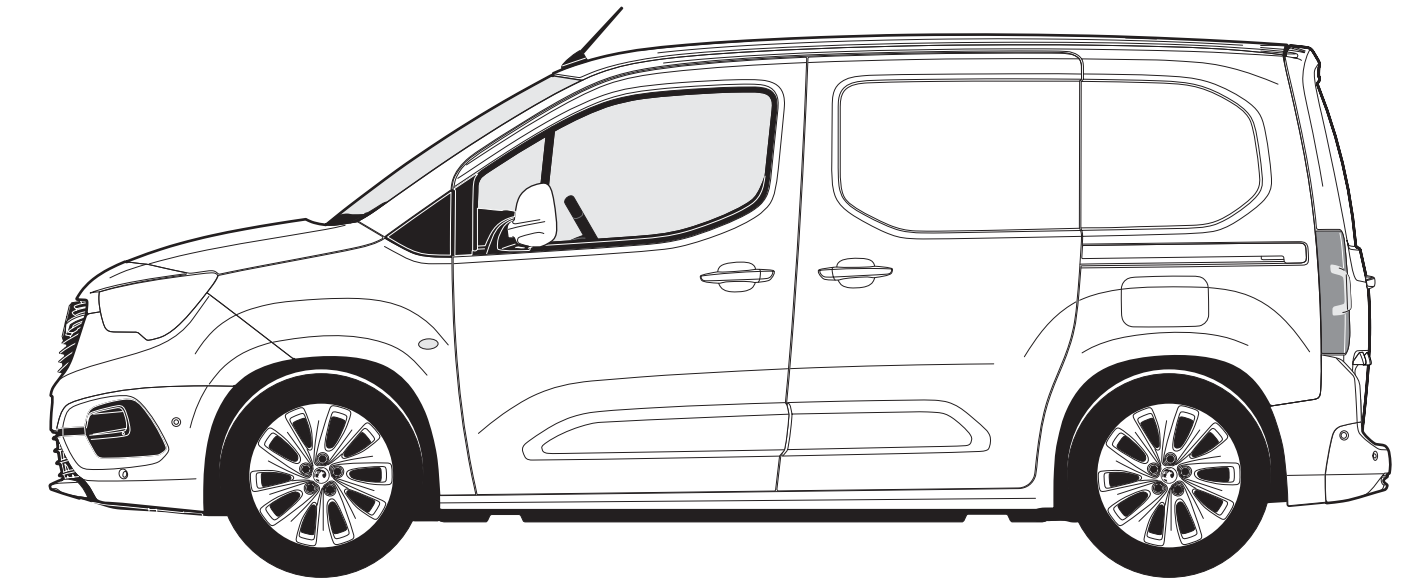

892 (35.1) 2785 (109.6) 726 (28.6)
4403 (173.3)

L1

1812-1860 (71.3-73.2)

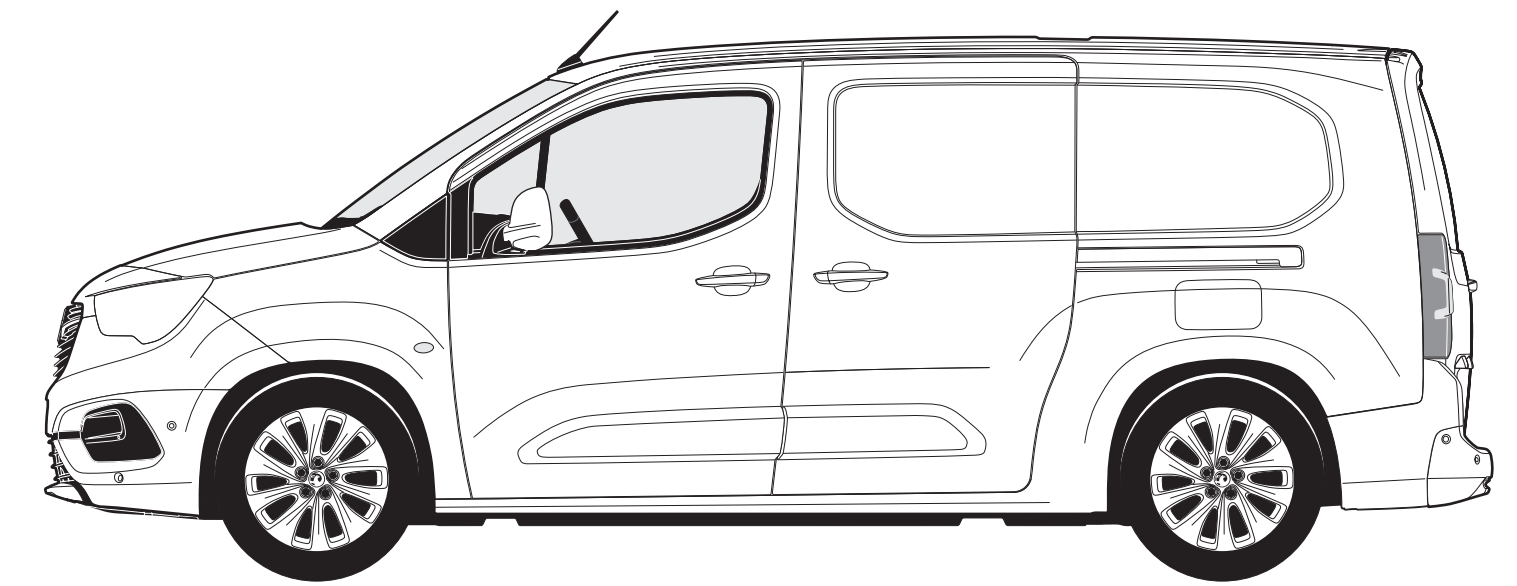

892 (35.1) 2975 (117.1) 886 (34.9)
4753 (187.1)

L2

ACCESSORIES

SAFETY	Total (exc. VAT)
Safety kit (first aid kit, hi-vis vest and warning triangle)	£13
Warning triangle	£7
First aid kit	£12
Hi-vis safety vest – Adult	£3
Emergency seat belt cutter and hammer	£15
Philips ADR620 dash cam	£90
PRACTICAL	
Spare bulb kit	£56
Stretch tow rope – 3 tonne	£28
Smokers pack	£32
PROTECTION	
Carpet mats (set of 2 – front)	£44
Rubber mats (set of 2 – front)	£41
Front parking sensors	£383
Rear parking sensors	£365
Rear window grilles	£143
Splash guards (rear)	£55
Wooden floor protection	
– Except sliding Door – L1	£218
Wooden floor protection – L2	£212
Wooden side panels	
– Except sliding door – L1	£385
Wooden side panels	
– For sliding door – L1	£385
Wooden side panels	
– For sliding door – L2	£416
Plastic floor protection	
– Except sliding door – L1	£238
Plastic floor protection – L2	£300
Plastic side panels	
– Except sliding door – L1	£578
Plastic side panels – For sliding door – L2	£679

TRANSPORT SYSTEMS	Total exc. VAT)
Roof base carrier ¹ (set of 2 bars) for vehicles without roof rails	£146
Roof base carrier (set of 2 bars) for vehicles with roof rails ¹	£173
Additional roof base carrier (1 bar)	£80
Aluminium roof rack (without roof rails)	
– L1	£668
– L2	£720
Steel roof rack (without roof rails)	
– L1	£545
– L2	£623
Roof Carriers	
Thule ladder tilt 311	£498
Thule ladder holder 330	£116
Thule ladder roller 335	£75
Thule front load stop system (side profiles)	£168
Thule front load stop system 321 (front)	£79
Thule ratchet tie down strap	£25
Thule fold down load stop 315	£50
Thule square bar adapter	£37
Roof carriers (requires base carrier)	
Bike roof carrier – Thule FreeRide 532	£65
Bike roof carrier – Thule Expert 298	£109
Surfboard roof carrier – Thule 833	£68
Ski roof carrier (up to 4 pairs) – Thule 7324	£116
Ski roof carrier (up to 6 pairs) – Thule 7326	£210

TRANSPORT SYSTEMS	Total (exc. VAT)
Hard shell roof boxes (requires base carrier)	
Thule Ocean 80	£205
Thule Ocean 200	£312
Thule Touring 200	£357
Thule Touring 700	£410
Thule Motion 800	from £441

Please note: Prices shown are fully fitted and painted, where applicable and exclude VAT. Please check with your local Vauxhall Retailer for details. It is advisable to ensure your insurance policy is adequate to cover additional fitted accessories. Prices correct at time of publication.

¹A dedicated T-Track adapter (Thule 697-4 or Thule 697-6) is required for the installation of specific roof boxes, contact your local Vauxhall Retailer for details.

GLOSSARY OF TERMS

Plated weight

The maximum weight to which a vehicle or an axle may be loaded, determined either by the design of the components or by legislation. All commercial vehicles must carry a manufacturer's 'plate' showing the vehicle and axle gross 'plated weights'. It is an offence to drive a vehicle in a condition where any of these weights are exceeded.

Minimum Mass

Minimum Mass ('Mass in running order' on Certificate of Conformity and 'Mass in Service' on V5C form) is defined according to European Type Approval and include all fluids, tools and 90% fuel load. It is minimum mass for this variant and does not consider local specification/trim or deletable options (specific to Movano). Weights are also subject to manufacturing tolerances (EU Legislation allows 5% tolerance).

Gross Vehicle Weight (GVW)

The total permissible weight of a vehicle including payload and passengers, as shown on the manufacturer's plate.

Gross Combination Weight (GCW)

The maximum permissible weight of a vehicle, including payload and passengers, combined with the total weight of any trailer it is towing. The maximum GCW weight limit is quoted on the vehicle plate and must not be exceeded.

Payload

The total permissible weight that can be carried without exceeding the vehicle's plated weight. Payload do not include driver but do take into consideration specification/trim level:

Weights are also subject to manufacturing tolerances (EU Legislation allows 5% tolerance). Payload does not consider any additional options that a customer may order.

Roof loads

- Combo roof load should not exceed 100kg including the weight of the roof rack/carrier
- Vivaro roof load should not exceed 170kg including the weight of the roof rack/carrier
- Movano roof load should not exceed 200kg (150kg on H1 models) including the weight of the roof rack/carrier. H3 are not permitted to carry roof loads

Maximum towing weight

The maximum weight of any trailer and its load which may be towed within the limit of the vehicle's plated Gross Combination Weight (GCW). It is based on the ability of the vehicle – at full GCW – to restart on a 12% gradient, which is approximately 1 in 8.3, at sea level. At altitudes above 1500 metres, the engine output may drop with a corresponding reduction in towing capability. It is the operator's responsibility to ensure that the trailer noseweight does not cause the rear axle plated weight of the towing vehicle to be exceeded.

Always fit Vauxhall towing attachments and accessories available from your Vauxhall Commercial Vehicle Retailer. They are designed specifically for Vauxhall models and carry a 12-month warranty.

Light Duty and Heavy Duty cycles

For a Light Duty cycle (EC regulation 715/2007 with designation 'Euro 6') the emissions of the whole vehicle are evaluated whereas for Heavy Duty cycle (EC regulation 595/2009 with designation 'Euro VI') only the engine is bench tested. The requirement of which cycle is necessary is determined by the reference mass of the vehicle. In the case of Movano, reference mass calculations dictate that:

- N1 FWD and M1 FWD are approved as Light Duty
- N1 RWD, N2 RWD and M2 FWD are approved as Heavy Duty

Conversions

With Vivaro a new conversion portal is introduced. This significantly improves the transparency and response of all communication with body-builders, and converters:

www.converters-and-groupe-psa.com

This website contains complete technical guidelines necessary to convert Vauxhall commercial vehicles – Combo (K9), Vivaro (K0) and Movano (X62). All vital and fundamental information is now located in one place:

- Conversion Guidelines
- Technical Data
- 3D CAD (coming)
- WLTP guidance
- Body shell ordering

Additionally there is a new Q&A service for technical questions, and the new conversion approval process will also be managed through this portal.

Any converter of Vauxhall product should create an account on this portal including those using IVA as approval process. In fact WLTP will make this necessary.

Commercial Vehicle Categories

Differences between M1/N1 and M2/N2 (Vehicles with GVW above 3500kg)

Category M: Passenger carriers

Category M1: Vehicles designed and constructed for the carriage of passengers and comprising no more than eight seats in addition to the driver's seat.

Category M2: Vehicles designed and constructed for the carriage of passengers, comprising more than eight seats in addition to the driver's seat, and having a maximum mass not exceeding 5 tonnes.

Category N: Goods vehicles

Category N1: Vehicles designed and constructed for the carriage of goods and having a maximum mass not exceeding 3.5 tonnes.

Category N2: Vehicles designed and constructed for the carriage of goods and having a maximum mass exceeding 3.5 tonnes but not exceeding 12 tonnes.

Specific differences, all M2/N2 require the following:

Speed limiter: All M2/N2 vehicles are legally required to be speed limited. M2 to 62mph and N2 to 56mph.

GLOSSARY OF TERMS

Driver licence: Commercial vehicles with GVW greater than 3.5 tonnes have different license requirements. For any new drivers C1 category is necessary. Under some circumstances (social purposes for a non-commercial body) it is possible to drive a minibus without a D1 entitlement (Minibus) however eligibility for this exemption should be confirmed with DVSA.

Driver CPC: Driver Certificate of Professional Competence mandates 35 hours of periodic training every 5 years to maintain licence (from September 2014).

Tachograph: It is a legal requirement to administer the activities of drivers subject to the EU or AETR drivers' hours rules, and also record the vehicle's speed, distance and time. A Smart Card is required for digital tachograph and these are available from the DVLA. The tachograph of a new vehicle must be calibrated within two weeks of first registration.

Operator's Licence: This may also be required to ensure that vehicles are kept safe and in good condition at all times. Specifically for M2, PSV (public service vehicle) operator's licence is required. Exemptions in some circumstances may be permitted but this should always be confirmed with DVSA.

MOT Testing: M2/N2 must be tested each year, and vehicle presented with a completed Certificate of Conformity (CoC). This is available from Vauxhall (regdata@gm.com) or from converter in case of second-stage conversion.

Conversions - WLTP

There is a mandatory CO₂ target that comes into effect in 2020. There are specific targets for both cars and light commercial vehicles. With respect to LCVs, Vauxhall will be responsible for the CO₂ of complete converted vehicle, and defined Maxi-Pollutant Values must be respected.

These values are:

- Mass in Running Order (kg)
- Frontal Surface (m²)
- Rolling Resistance Coefficient of tyres (kg/t)
- Air Inlet Surface to cool the engine (dm²)

Conversion Guidelines; Maxi-Pollutant Values and links to CO₂ calculator can all be found on the converter portal at www.converters-and-groupe-psa.com

Second-stage conversions based on a Euro 6D TEMP engine cannot be registered unless they have passed the CO₂ calculator. If Maxi-Pollutant values are not followed, then CO₂ calculation will fail and converted vehicle cannot be registered. It would be necessary then to change the conversion.

FURTHER INFORMATION

Vauxhall on-the-road recommended retail prices (RRP)

To eliminate uncertainty about hidden costs incurred when buying a new commercial vehicle, Vauxhall publishes on-the-road prices and these are shown in the pricing tables within this price guide. The prices shown are manufacturer's recommended retail prices (RRP) unless otherwise stated, exclusive of VAT (currently at a rate of 20% which may be payable). These prices include the recommended cost of number plates, delivery to a Vauxhall Retailer of £583.33 (£700.00 including VAT), 12 months' Government Vehicle Excise Duty* and the DVLA new vehicle first registration fee of £55.00*.

Please note: The RRP does not include fuel supplied by the Retailer, motor insurance or any other goods or services supplied by agreement between the Retailer and customer.

Price protection for all Vauxhalls

Order a new Vauxhall for build in the current model year (as confirmed by your Retailer) for delivery no more than three months in advance and the price you are quoted is the price you pay. This is irrespective of any subsequent price rises between placing your order and delivery of your new commercial vehicle, but you must take delivery as soon as the commercial vehicle is available. Vauxhall Motors Limited is not liable for price adjustments caused by Government changes in the rate of VAT (currently 20%), Vehicle Excise Duty, DVLA new vehicle first registration fee or by any other applicable legislation or regulations.

In the event of an accident...

Vauxhall Accident Management helps keep you mobile following an accident. Benefits include vehicle recovery, Vauxhall-approved repairs and contacting your insurer. For more details, visit www.vauxhall.co.uk/AccidentManagement

Vehicle Excise Duty

The amount of Vehicle Excise Duty (road fund licence) payable on new commercial vehicles varies depending on gross vehicle weight (GVW) and European standard emissions compliance, as shown below*.

Up to 3500kg GVW	£265.00
Over 3500kg GVW	£165.00

*Correct at time of publication.

Customer Care Commitment

For added peace of mind, Vauxhall has an innovative Customer Care Commitment** that offers the following:

- Three-year vehicle warranty consisting of a one-year/unlimited mileage manufacturer's warranty and a second and third year manufacturer's warranty with a 60,000 miles (Combo) and 100,000 miles (Vivaro and Movano) limitation
- Vauxhall Assistance for 12 months from first registration
- Five years' body panel anti-perforation warranty

**Warranty is only on vehicles sourced from Vauxhall Motors Limited. Terms and conditions apply – please see your Vauxhall Retailer for details.

Vauxhall Assistance

Vauxhall Assistance is provided Automatically with every new Vauxhall Commercial Vehicle for 12 months from first registration and covers everything from accidents, mechanical breakdown to flat tyres. With Vauxhall Assistance help is literally just a free[†] phone call away, 24 hours a day, 365 days a year!

[†]Mobile phone users will be charged at their standard tariff.

Vauxhall Extended Warranty

For complete peace of mind Vauxhall offers an extended warranty that can be purchased on an annual basis following the expiry of the original new vehicle warranty. It covers most mechanical

and electrical components. Terms and conditions apply, for further details please contact your local Vauxhall Retailer.

Protecting the environment

Our products are increasingly winning environmental awards, both through the use of more recycled materials and by becoming cleaner and more efficient. For information on Vauxhall's efforts to achieve an environmentally sustainable future, including information on Design for Recycling, take-back of End-of-Life Vehicles (ELVs), and the recycling of ELVs, see www.vauxhall.co.uk/recycling

Van Business Centres

Keeping your van on the road. We know how important your van is to you, that's why we're geared up to minimise your downtime.

Our nationwide Van Business Centres provide fast, convenient value for money servicing, repairs and MOTs.

- All work is carried out by Vauxhall trained technicians using only genuine parts
- No appointments are required for diagnosis and we offer a 'while you wait' service

We have all the expertise required and will spare no effort to get you back in business as soon as possible.

Vauxhall Service Plan

Vauxhall Retailers offer a great service for owners of all Vauxhall vehicles. Value for money, regular offers and free check-ups, combined with the peace of mind that comes from using Vauxhall-trained technicians and genuine parts, help keep your vehicle in peak condition at all times. Every Vauxhall Retailer supports our customer promise:

We are Vauxhall experts

- Fully Vauxhall-trained technicians
- We use Vauxhall approved diagnostic equipment and specialist tools
- Full access to Vauxhall repair databases and technical centres

We are transparent

- Our invoicing will clearly set out the work at the price agreed with no hidden extras

We are never beaten on price

- We will match any written like for like service/repair quote from a local^{††} competitor using genuine repair methods and parts

We are convenient

- Flexible booking times to suit you
- 'One-stop shop' for every type of Vauxhall service
- While you wait facility on stocked tyres, batteries and exhausts
- Free courtesy vehicle or local collection with annual services and warranty work

We are thorough

- 25 point safety check with any workshop visit
- No obligation advice on essential and non-essential work
- Free check for safety enhancements and upgrades to your vehicle and software
- Free 'Wash and Vac' with every annual service
- Free fitting of wipers and external bulbs with annual services

^{††}A radius of five miles/20 minutes from your Vauxhall Retailer.

For more product information

For further information on the Vauxhall range or location of your nearest Vauxhall Retailer please call 0345 600 1500. Alternatively, details can be found on our website at www.vauxhall.co.uk

For more information call **0345 600 1500**

Discover the full Vauxhall range at **[vauxhall.co.uk](https://www.vauxhall.co.uk)**

Join us online

The invoice price, including delivery to Retailer, factory-fitted options, accessories fitted by the Retailer and number plates, is subject to VAT. Some feature descriptions in this guide may refer to, and some illustrations may show, optional equipment not included in the standard delivery. The information contained in this guide was accurate at the time of publication. We reserve the right to make changes in design and equipment. Please note that Vauxhall Retailers are not the agents of Vauxhall Motors Limited and are not authorised to bind Vauxhall Motors Limited by any specific or implied undertaking or representation. It is advisable to ensure that your motor insurance policy provides adequate cover for additional fitted options and accessories. The colours in this guide are only approximate actual colours. Illustrated optional equipment is available at extra charge. Availability, technical features and equipment provided on our vehicles can vary by model. For precise information on the equipment provided on our vehicles, please contact your local Vauxhall Retailer.

VAUXHALL

Price and Specification Guide
21 January 2021. Model Year 2021.5



Vivaro

Including Vivaro-e Range

CONTENTS

To find the information you want use the links below to navigate around the guide:

[Range Highlights](#)

[Models](#)

[Prices and Weights](#)

[Fuel Economy and Emissions](#)

[Features and Options](#)

[Exterior Colours](#)

[Wheels and Tyres](#)

[Specifications](#)

[Dimensions](#)

[Accessories](#)

[Glossary of Terms](#)

[Further Information](#)

NEW VIVARO-E RANGE HIGHLIGHTS



VX_VIV_30351



VX_VIV_31196

DYNAMIC

OTR from £29,028.33*

Standard features include:

- Automatic transmission with e-toggle shift
- Electric parking brake
- Electronic stability programme
- Traction control
- ABS with electronic brakeforce distribution
- Hill start assist
- Driver and front passengers' airbag
- Remote control central deadlocking
- Selective door locking
- Full-height steel bulkhead (Panel Van only)
- Six-way adjustable driver's seat with lumbar adjustment and armrest
- Dual front passengers' bench seat with underseat storage
- Multi-function trip computer
- 3.5-inch digital instrument cluster
- Cruise control with speed limiter
- Vauxhall Connect box
- Multimedia infotainment unit
- 7-inch colour touchscreen
- Digital radio/AM/FM stereo radio
- Bluetooth® connectivity
- Steering wheel mounted audio and phone controls
- Nearside and offside sliding side-access doors
- Twin solid rear doors
- Electrically operated front windows with one-touch facility
- Electrically adjustable/heated door mirrors
- Remote control security alarm system
- Driver drowsiness alert (based on driving time)
- Cab soundproofing
- Laminated acoustic windscreen
- Front fog lights
- Rear parking distance sensors
- Rain-sensitive windscreen wipers
- Automatic lighting control
- Front cornering lights
- 16-inch steel wheels with full-diameter wheel trims
- Steel spare wheel

ELITE

OTR from £37,378.33*

Features over Dynamic:

- FlexCargo load-through bulkhead (Panel Van only)
- Fold-flat centre seat backrest providing flat work surface
- Multimedia Navi Pro satellite navigation system
- 7-inch colour touchscreen
- 3.5-inch colour information display
- Head-up display
- Panoramic rear-view camera
- Body-colour front bumpers
- Body-colour rear bumpers (L1)
- Body-colour rear corner bumper with black centre section (L2)
- Chrome-effect front grille
- Front fog lights
- Rear parking distance sensors
- Rain-sensitive windscreen wipers
- Automatic lighting control
- LED daytime running lights
- Lane departure warning
- Speed sign recognition with intelligent speed adaptation
- Side blind spot alert
- Semi-adaptive cruise control
- Forward collision alert with Automatic emergency braking and pedestrian detection
- Electrically folding door mirrors
- Front and rear parking distance sensors
- 17-inch silver alloy wheels
- Two-coat metallic paint

Please note: Vivaro-e includes a regulatory sound up to 18mph. Above this speed, road noise is sufficient and it is not necessary to have additional sound to forewarn pedestrians.

*Price shown is after allowing for PiVG (Plug-in Van Grant) and excludes VAT.

VIVARO RANGE HIGHLIGHTS



VX_VIV_31097

EDITION OTR from £24,378.33*

Standard features include:

- Electronic stability programme
- Traction control
- ABS with electronic brakeforce distribution
- Hill start assist
- Driver and front passengers' airbag
- Remote control central deadlocking
- Selective door locking
- Full-height steel bulkhead (Panel Van only)
- Six-way adjustable driver's seat with lumbar adjustment and armrest
- Dual front passengers' bench seat with underseat storage
- Multi-function trip computer
- Cruise control with speed limiter
- Vauxhall Connect box
- Digital radio/AM/FM stereo radio
- Bluetooth® connectivity
- Steering wheel mounted audio and phone controls
- Facia-mounted drinks holders
- Nearside and offside sliding side-access doors
- Twin solid rear doors
- Electrically operated front windows with one-touch facility
- Electrically adjustable/heated door mirrors
- 16-inch steel wheels
- Steel spare wheel



VX_VIV_30351

DYNAMIC OTR from £25,468.33*

Features over Edition:

- Remote control security alarm system
- Driver drowsiness alert (based on driving time)
- Cab soundproofing
- Multimedia infotainment unit
- 7-inch colour touchscreen
- Air conditioning
- Laminated acoustic windscreen
- Front fog lights
- Rear parking distance sensors
- Rain-sensitive windscreen wipers
- Automatic lighting control
- Front cornering lights
- 16-inch steel wheels with full-diameter wheel trims



VX_VIV_29502

SPORTIVE OTR from £26,628.33*

Features over Edition:

- FlexCargo load-through bulkhead (Panel Van only)
- Remote control security alarm system
- Driver drowsiness alert (based on driving time)
- Fold-flat centre seat backrest providing flat work surface
- Cab soundproofing
- Multimedia infotainment unit
- 7-inch colour touchscreen
- Air conditioning
- Laminated acoustic windscreen
- Body-colour front bumpers
- Body-colour rear bumpers (L1)
- Body-colour rear corner bumper with black centre section (L2)
- Chrome-effect front grille
- Front fog lights
- Rear parking distance sensors
- Rain-sensitive windscreen wipers
- Automatic lighting control
- LED daytime running lights
- Front cornering lights
- 16-inch steel wheels with full-diameter wheel trims
- Two-coat metallic paint



VX_VIV_31151

ELITE OTR from £30,518.33*

Features over Sportive:

- Multimedia Navi Pro satellite navigation system
- Lane departure warning
- Speed sign recognition with intelligent speed adaptation
- Side blind spot alert
- Semi-adaptive cruise control
- Forward collision alert with Automatic emergency braking and pedestrian detection
- 3.5-inch colour information display
- Head-up display
- Panoramic rear-view camera
- Electrically folding door mirrors
- Front and rear parking distance sensors
- 17-inch silver alloy wheels

NEW VIVARO-E DYNAMIC



VX_VIV_30351

L1 PANEL VAN ON-THE-ROAD PRICES

	OTR RRP after PiVG exc. VAT*	Insurance Group
3100 100kw (136PS) auto – 50kWh battery	£29,028.33	38E
3100 100kw (136PS) auto – 75kWh battery	£33,528.33	40E

L2 PANEL VAN ON-THE-ROAD PRICES

3100 100kw (136PS) auto – 50kWh battery	£30,178.33	38E
3100 100kw (136PS) auto – 75kWh battery	£34,678.33	41E

L1 PLATFORM CAB ON-THE-ROAD PRICES

3100 100kW (136PS) auto – 50kW battery	tba	–
3100 100kW (136PS) auto – 75kW battery	tba	–

Please note: On-the-road recommended retail prices (RRP) include number plates and delivery to Retailer of £583.33 and new vehicle first registration fee of £55.00. Excludes fuel and insurance.

*Price shown is after allowing for PiVG (Plug-in Van Grant).

FEATURES

Infotainment:

- Multimedia audio system
 - 7-inch colour touchscreen
 - 3.5-inch digital instrument cluster
 - AM/FM/DAB digital radio
 - Bluetooth® audio streaming
 - Bluetooth® mobile phone portal
 - Apple CarPlay™/Android Auto™
 - USB audio connection

Interior convenience/styling:

- Automatic transmission with e-toggle shift
- Electric parking brake
- Air conditioning
- Multi-function trip computer
- Cruise control with speed limiter
- Vauxhall Connect box
- Steering column mounted audio and phone controls
- Six-way adjustable driver's seat with lumbar adjustment and armrest
- Dual front passengers' bench seat with underseat storage

Exterior convenience/styling:

- Rear parking distance sensors
- Laminated acoustic windscreen
- Front fog lights
- Front cornering light
- High beam assist
- Daytime running lights
- Rain-sensitive windscreen wipers
- Electrically adjustable/heated door mirrors
- Electrically operated front windows
- Nearside and offside sliding side-access doors
- Twin solid rear doors
- Side-protection mouldings
- 16-inch steel wheels with full-diameter wheel trims

Safety/security:

- Driver and front passengers' airbags
- Height-adjustable front lap and diagonal inertia-reel seatbelts
- Electronic stability programme with traction control
- Anti-lock braking system
- Full-height steel bulkhead
- Hill start assist
- Remote control central deadlocking
- Selective door locking
- Electronic engine deadlock immobiliser
- Remote control security alarm system

NEW VIVARO-E ELITE



VX_VIV_31196

L1 PANEL VAN ON-THE-ROAD PRICES

	OTR RRP after PiVG exc. VAT*	Insurance Group
3100 100kw (136PS) auto – 75kWh battery	£37,378.33	41E

L2 PANEL VAN ON-THE-ROAD PRICES

3100 100kw (136PS) auto – 75kWh battery	£38,528.33	41E
-----------------------------------------	-------------------	-----

L2 DOUBLECAB ON-THE-ROAD PRICES

3100 100kw (136PS) auto – 75kWh battery	£40,528.33	42E
-----------------------------------------	-------------------	-----

Please note: On-the-road recommended retail prices (RRP) include number plates and delivery to Retailer of £583.33, 12 months' Vehicle Excise Duty (£265.00) and new vehicle first registration fee of £55.00. Excludes fuel and insurance.

*Price shown is after allowing for PiVG (Plug-in Van Grant).

FEATURES

Infotainment:

- Multimedia Navi Pro
 - Fully integrated European sat nav system
 - 7-inch colour touchscreen
 - 3.5-inch digital instrument cluster
 - Voice control
 - AM/FM/DAB digital radio
 - Bluetooth® audio streaming
 - Bluetooth® mobile phone portal
 - USB audio connection
 - Second USB charging connection
 - Four speakers

Interior convenience/styling:

- Automatic transmission with e-toggle shift
- Electric parking brake
- Air conditioning
- FlexCargo load-through bulkhead
- Multi-function trip computer
- Cruise control with speed limiter
- Vauxhall Connect box
- Steering column mounted audio and phone controls
- Six-way adjustable driver's seat with lumbar adjustment and armrest
- Dual front passengers' bench seat with underseat storage
- Three-individually contoured rear seats
 - Doublecab models

Please note: Doublecab rear seating is not equipped with ISOFIX child seat mountings.

Exterior convenience/styling:

- Front and rear parking distance sensors
- Heat-reflective/acoustic windscreen
- Body-colour front bumpers
- Body-colour rear bumpers (L1)
- Body-colour rear corner bumper with black centre section (L2)
- Chrome-effect front grille
- Front fog lights

- Front cornering light
- Rain-sensitive windscreen wipers
- Electrically adjustable/heated door mirrors

Exterior convenience/styling continued:

- Electrically folding door mirrors
- Electrically operated front windows with one-touch facility
- Nearside and offside sliding side-access doors
- Twin solid rear doors
- Side-protection mouldings
- 17-inch silver alloy wheels

Safety/security:

- Lane departure warning
- Speed sign recognition with intelligent speed adaptation
- Side blind spot alert
- Semi-adaptive cruise control
- Forward collision alert with Automatic emergency braking and pedestrian detection
- Head-up display
- Panoramic rear-view camera
- Driver drowsiness system
- Driver and front passengers' airbags
- Driver and front passengers' curtain and side-impact airbags – Doublecab model
- Height-adjustable front lap and diagonal inertia-reel seatbelts
- Electronic stability programme with traction control
- Anti-lock braking system
- Full-height steel bulkhead
- Full-height ABS plastic bulkhead with window
 - Doublecab models
- Hill start assist
- Daytime running lights
- Remote control central deadlocking
- Selective door locking
- Electronic engine deadlock immobiliser
- Remote control security alarm system

VIVARO EDITION



VX_VIV_31097

L1 PANEL VAN ON-THE-ROAD PRICES

	OTR RRP exc. VAT	Insurance Group
2700 1.5 (100PS) Turbo D S/S	£24,378.33	35A
2900 1.5 (100PS) Turbo D S/S	£24,878.33	36A
3100 2.0 (120PS) Turbo D S/S	£25,578.33	40A

L2 PANEL VAN ON-THE-ROAD PRICES

2900 1.5 (100PS) Turbo D S/S	£25,278.33	37A
3100 2.0 (120PS) Turbo D S/S	£26,478.33	40A

L1 DOUBLECAB ON-THE-ROAD PRICES

3100 2.0 (120PS) Turbo D S/S	£28,108.33	40A
------------------------------	-------------------	-----

L2 DOUBLECAB ON-THE-ROAD PRICES

3100 2.0 (120PS) Turbo D S/S	£29,008.33	39A
------------------------------	-------------------	-----

Please note: On-the-road recommended retail prices (RRP) include number plates and delivery to Retailer of £583.33, 12 months' Vehicle Excise Duty (£265.00) and new vehicle first registration fee of £55.00. Excludes fuel and insurance.

S/S = Start/Stop.

FEATURES

Infotainment:

- AM/FM/DAB digital radio
- Bluetooth® audio streaming
- Bluetooth® mobile phone portal
- USB audio connection

Interior convenience/styling:

- Multi-function trip computer
- Cruise control with speed limiter
- Vauxhall Connect box
- Steering column mounted audio and phone controls
- Six-way adjustable driver's seat with lumbar adjustment and armrest
- Dual front passengers' bench seat with underseat storage
- Three-individually contoured rear seats – Doublecab models

Please note: Doublecab rear seating is not equipped with ISOFIX child seat mountings.

Exterior convenience/styling:

- Electrically adjustable/heated door mirrors
- Electrically operated front windows
- Nearside and offside sliding side-access doors
- Twin solid rear doors
- Side-protection mouldings

Safety/security:

- Driver and front passengers' airbags
- Driver and front passengers' curtain and side-impact airbags – Doublecab models
- Height-adjustable front lap and diagonal inertia-reel seatbelts
- Electronic stability programme with traction control
- Anti-lock braking system
- Full-height steel bulkhead – Panel Van
- Folding bulkhead with integrated steel-framed mesh – Doublecab models
- Hill start assist
- Daytime running lights
- Remote control central deadlocking
- Selective door locking
- Electronic engine deadlock immobiliser

VIVARO DYNAMIC



VX_VIV_30351

L1 PANEL VAN ON-THE-ROAD PRICES

	OTR RRP exc. VAT	Insurance Group
2700 1.5 (100PS) Turbo D S/S	£25,468.33	34E
2700 1.5 (120PS) Turbo D S/S	£26,168.33	35E
2900 1.5 (100PS) Turbo D S/S	£25,968.33	35E
3100 2.0 (120PS) Turbo D S/S	£26,668.33	39E

L2 PANEL VAN ON-THE-ROAD PRICES

2900 1.5 (100PS) Turbo D S/S	£26,368.33	36E
3100 2.0 (120PS) Turbo D S/S	£27,568.33	39E
3100 2.0 (120PS) Turbo D S/S auto	£29,368.33	40E

Please note: On-the-road recommended retail prices (RRP) include number plates and delivery to Retailer of £583.33, 12 months' Vehicle Excise Duty (£265.00) and new vehicle first registration fee of £55.00. Excludes fuel and insurance.

S/S = Start/Stop.

FEATURES

Infotainment:

- Multimedia audio system
 - 7-inch colour touchscreen
 - AM/FM/DAB digital radio
 - Bluetooth® audio streaming
 - Bluetooth® mobile phone portal
 - Apple CarPlay™/Android Auto™
 - USB audio connection

Interior convenience/styling:

- Air conditioning
- Multi-function trip computer
- Cruise control with speed limiter
- Vauxhall Connect box
- Steering column mounted audio and phone controls
- Six-way adjustable driver's seat with lumbar adjustment and armrest
- Dual front passengers' bench seat with underseat storage

Exterior convenience/styling:

- Rear parking distance sensors
- Laminated acoustic windscreen
- Front fog lights
- Front cornering light
- High beam assist
- Daytime running lights
- Rain-sensitive windscreen wipers
- Electrically adjustable/heated door mirrors
- Electrically operated front windows
- Nearside and offside sliding side-access doors
- Twin solid rear doors
- Side-protection mouldings
- 16-inch steel wheels with full-diameter wheel trims

Safety/security:

- Driver and front passengers' airbags
- Height-adjustable front lap and diagonal inertia-reel seatbelts
- Electronic stability programme with traction control
- Anti-lock braking system
- Full-height steel bulkhead
- Hill start assist
- Remote control central deadlocking
- Selective door locking
- Electronic engine deadlock immobiliser
- Remote control security alarm system

VIVARO SPORTIVE



VX_VIV_29502

L1 PANEL VAN ON-THE-ROAD PRICES

	OTR RRP exc. VAT	Insurance Group
2700 1.5 (100PS) Turbo D S/S	£26,628.33	35E
2700 1.5 (120PS) Turbo D S/S	£27,328.33	36E
3100 2.0 (120PS) Turbo D S/S	£27,828.33	39E

L2 PANEL VAN ON-THE-ROAD PRICES

2900 1.5 (100PS) Turbo D S/S	£27,528.33	36E
3100 2.0 (120PS) Turbo D S/S	£28,728.33	39E
3100 2.0 (120PS) Turbo D S/S auto	£30,528.33	40E
3100 2.0 (150PS) Turbo D S/S	£29,828.33	40E

L2 DOUBLECAB ON-THE-ROAD PRICES

3100 2.0 (120PS) Turbo D S/S	£30,728.33	38E
3100 2.0 (120PS) Turbo D S/S auto	£32,528.33	39E

Please note: On-the-road recommended retail prices (RRP) include number plates and delivery to Retailer of £583.33, 12 months' Vehicle Excise Duty (£265.00) and new vehicle first registration fee of £55.00. Excludes fuel and insurance.

S/S = Start/Stop.

FEATURES

Infotainment:

- Multimedia audio system
 - 7-inch colour touchscreen
 - AM/FM/DAB digital radio
 - Bluetooth® audio streaming
 - Bluetooth® mobile phone portal
 - Apple CarPlay™/Android Auto™
 - Bluetooth® mobile phone portal
 - USB audio connection

Interior convenience/styling:

- Air conditioning
- FlexCargo load-through bulkhead
- Multi-function trip computer
- Cruise control with speed limiter
- Vauxhall Connect box
- Steering column mounted audio and phone controls
- Six-way adjustable driver's seat with lumbar adjustment and armrest
- Dual front passengers' bench seat with underseat storage
- Three-individually contoured rear seats
 - Doublecab models

Please note: Doublecab rear seating is not equipped with ISOFIX child seat mountings.

Exterior convenience/styling:

- Rear parking distance sensors
- Laminated acoustic windscreen
- Body-colour front bumpers
- Body-colour rear bumpers (L1)
- Body-colour rear corner bumper with black centre section (L2)
- Body-colour side-protection mouldings
- Body-colour door handles and mirror housings
- Chrome-effect front grille
- Front fog lights
- Front cornering light
- High beam assist
- LED daytime running lights
- Rain-sensitive windscreen wipers
- Electrically adjustable/heated door mirrors
- Electrically operated front windows
- Nearside and offside sliding side-access doors
- Twin solid rear doors
- Side-protection mouldings
- 16-inch steel wheels with full-diameter wheel trims

Safety/security:

- Driver and front passengers' airbags
- Driver and front passengers' curtain and side-impact airbags – Doublecab models
- Height-adjustable front lap and diagonal inertia-reel seatbelts
- Electronic stability programme with traction control
- Anti-lock braking system
- Full-height steel bulkhead – Panel Van
- Full-height ABS plastic bulkhead with window
 - Doublecab only
- Hill start assist
- Remote control central deadlocking
- Selective door locking
- Electronic engine deadlock immobiliser
- Remote control security alarm system

VIVARO ELITE



VX_VIV_31151

L1 PANEL VAN ON-THE-ROAD PRICES

	OTR RRP exc. VAT	Insurance Group
3100 2.0 (120PS) Turbo D S/S	£30,518.33	40E
3100 2.0 (180PS) Turbo D S/S auto	£34,018.33	42E

L2 PANEL VAN ON-THE-ROAD PRICES

3100 2.0 (120PS) Turbo D S/S	£31,418.33	40E
3100 2.0 (150PS) Turbo D S/S	£32,518.33	41E
3100 2.0 (180PS) Turbo D S/S auto	£34,918.33	42E

L2 DOUBLECAB ON-THE-ROAD PRICES

3100 2.0 (120PS) Turbo D S/S	£33,418.33	39E
3100 2.0 (150PS) Turbo D S/S	£34,518.33	40E
3100 2.0 (180PS) Turbo D S/S auto	£36,918.33	42E

Please note: On-the-road recommended retail prices (RRP) include number plates and delivery to Retailer of £583.33, 12 months' Vehicle Excise Duty (£265.00) and new vehicle first registration fee of £55.00. Excludes fuel and insurance.

S/S = Start/Stop.

FEATURES

Infotainment:

- Multimedia Navi Pro
 - Fully integrated European sat nav system
 - 7-inch colour touchscreen
- Voice control
- AM/FM/DAB digital radio
- Bluetooth® audio streaming
- Bluetooth® mobile phone portal
- USB audio connection
- Second USB charging connection
- Four speakers

Interior convenience/styling:

- Air conditioning
- FlexCargo load-through bulkhead
- Multi-function trip computer
- Cruise control with speed limiter
- Vauxhall Connect box
- Steering column mounted audio and phone controls
- Six-way adjustable driver's seat with lumbar adjustment and armrest
- Dual front passengers' bench seat with underseat storage
- Three-individually contoured rear seats
 - Doublecab models

Please note: Doublecab rear seating is not equipped with ISOFIX child seat mountings.

Exterior convenience/styling:

- Front and rear parking distance sensors
- Heat-reflective/acoustic windscreen
- Body-colour front bumpers
- Body-colour rear bumpers (L1)
- Body-colour rear corner bumper with black centre section (L2)
- Chrome-effect front grille
- Front fog lights
- Front cornering light
- Rain-sensitive windscreen wipers
- Electrically adjustable/heated door mirrors

Exterior convenience/styling continued:

- Electrically folding door mirrors
- Electrically operated front windows with one-touch facility
- Nearside and offside sliding side-access doors
- Twin solid rear doors
- Side-protection mouldings
- 17-inch silver alloy wheels

Safety/security:

- Lane departure warning
- Speed sign recognition with intelligent speed adaptation
- Side blind spot alert
- Semi-adaptive cruise control
- Forward collision alert with Automatic emergency braking and pedestrian detection
- 3.5-inch colour information display
- Head-up display
- Panoramic rear-view camera
- Driver drowsiness system
- Driver and front passengers' airbags
- Driver and front passengers' curtain and side-impact airbags - Doublecab model
- Height-adjustable front lap and diagonal inertia-reel seatbelts
- Electronic stability programme with traction control
- Anti-lock braking system
- Full-height steel bulkhead
- Full-height ABS plastic bulkhead with window
 - Doublecab models
- Hill start assist
- Daytime running lights
- Remote control central deadlocking
- Selective door locking
- Electronic engine deadlock immobiliser
- Remote control security alarm system

NEW VIVARO-E PANEL VAN PRICES/WEIGHTS

	Pack Code	Minimum Mass (kg)*	Maximum indicative payload (kg)*	Gross Vehicle Weights (GVW) (kg)	Plated weights (kg)		Towing weights (kg) Braked	Plated Gross Combination Weights (GCW) (kg)	Price (£) exc. VAT	On-the-road RRP before PiVG (£) exc. VAT	On-the-road RRP after PiVG (£) exc. VAT
					Front axle	Rear axle					
L1 DYNAMIC PANEL VAN											
3100 100kw (136PS) auto – 50kWh battery	8G05 9CQW	1874	1226	3100	1500	1800	1000	4100	34,390.00	35,028.33	29,028.33
3100 100kw (136PS) auto – 75kWh battery	8G05 9DQW	2100	1000	3100	1500	1800	1000	4100	38,890.00	39,528.33	33,528.33
L2 DYNAMIC PANEL VAN											
3100 100kw (136PS) auto – 50kWh battery	8G05 9CQ1	1902	1198	3100	1500	1800	1000	4100	35,540.00	36,178.33	30,178.33
3100 100kw (136PS) auto – 75kWh battery	8G05 9DQ1	2053	1002	3055	1500	1500	1000	4055	40,040.00	40,678.33	34,678.33
L1 ELITE PANEL VAN											
3100 100kw (136PS) auto – 75kWh battery	8H05 9DQW	2100	1000	3100	1500	1800	1000	4100	42,740.00	43,378.33	37,378.33
L2 ELITE PANEL VAN											
3100 100kw (136PS) auto – 75kWh battery	8H05 9DQ1	2053	1002	3055	1500	1800	1000	4055	43,890.00	44,528.33	38,528.33
L2 ELITE DOUBLECAB											
3100 100kw (136PS) auto – 75kWh battery**	8HC5 9DQ1	2113	987	3100	1500	1800	1000	4100	45,890.00	46,528.33	40,528.33
L1 DYNAMIC PLATFORM CAB											
3100 100kW (136PS) auto – 50kW battery	8F03 9CQW	tba	tba	tba	tba	tba	tba	tba	33,325.00	33,963.33	tba
3100 100kW (136PS) auto – 75kW battery	8F03 9DQW	tba	tba	tba	tba	tba	tba	tba	37,825.00	38,463.33	tba

Please note: On-the-road recommended retail prices (RRP) include number plates and delivery to Retailer of £583.33 exc. VAT (£700.00 inc. VAT) and new vehicle first registration fee of £55.00 (correct at time of publication). Excludes fuel and insurance. Price has been calculated using manufacturer estimates and includes an OZEV grant of up to £6,000.00 which has been deducted from the price of the vehicle (OZEV Grant not available in the Isle of Man). The grant is a government incentive and is subject to withdrawal prior to delivery of your vehicle. Retailers may be required to carry out more than one credit check during the course of the order process. You may be required to place a deposit when placing your order with your supplying Retailer. In the event of a price change, deposit refunds will be governed by your supplying Retailer's policy and as such must be discussed with the supplying Retailer.

Gross plated weights (including axle weights) quoted on the vehicle plate are to UK plated weight specification and must never be exceeded. Unbraked towing weight 750kg – all models.

*Minimum Mass for standard vehicles will vary according to the vehicle specification (including trim, options and accessories) with a corresponding variation in payload.

**VAT reclaimable status requires a minimum 1-tonne payload for Doublecabs in accordance with HMRC guidance. Doublecabs with a payload of less than 1-tonne may be eligible for VAT reclaimable status, subject to further HMRC assessment. Customers are advised to consult their local HMRC office or visit <https://www.gov.uk/government/organisations/hm-revenue-customs> for further details in relation to VAT reclaimable status. Payload calculations should take into consideration local UK Specification and Trim Level. Ordered options may also impact payload.

VIVARO PANEL VAN PRICES/WEIGHTS

	Pack Code	Minimum Mass (kg)*	Maximum indicative payload (kg)*	Gross Vehicle Weights (GVW) (kg)	Plated weights (kg)		Towing weights (kg) Braked	Plated Gross Combination Weights (GCW) (kg)	Price (£) exc. VAT	On-the-road RRP (£) exc. VAT
					Front axle	Rear axle				
L1 EDITION PANEL VAN EURO 6D TEMP (6.2)										
2700 1.5 (100PS) Turbo D S/S	8C05 iILW	1660	975	2635	1500	1500	1400	4035	23,475.00	24,378.33
2900 1.5 (100PS) Turbo D S/S	8C05 iILZ	1660	1170	2830	1500	1800	1400	4230	23,975.00	24,878.33
3100 2.0 (120PS) Turbo D S/S	8C05 MKPW	1642	1458	3100	1500	1800	2500	5000	24,675.00	25,578.33
L1 DYNAMIC PANEL VAN EURO 6D TEMP (6.2)										
2700 1.5 (100PS) Turbo D S/S	8D05 iILW	1660	975	2635	1500	1500	1400	4035	24,565.00	25,468.33
2700 1.5 (120PS) Turbo D S/S	8D05 iNLW	1581	1079	2660	1500	1500	1800	4460	25,265.00	26,168.33
2900 1.5 (100PS) Turbo D S/S	8D05 iILZ	1660	1170	2830	1500	1800	1400	4230	25,065.00	25,968.33
3100 2.0 (120PS) Turbo D S/S	8D05 MKPW	1642	1458	3100	1500	1800	2500	5000	25,765.00	26,668.33
L1 SPORTIVE PANEL VAN EURO 6D TEMP (6.2)										
2700 1.5 (100PS) Turbo D S/S	8D05 iILY	1660	975	2635	1500	1500	1400	4035	25,725.00	26,628.33
2700 1.5 (120PS) Turbo D S/S	8D05 iNLY	1581	1079	2660	1500	1500	1800	4460	26,425.00	27,328.33
3100 2.0 (120PS) Turbo D S/S	8D05 MKPY	1642	1458	3100	1500	1800	2500	5000	26,925.00	27,828.33
L1 ELITE PANEL VAN EURO 6D TEMP (6.2)										
3100 2.0 (120PS) Turbo D S/S	8E05 MKPW	1642	1458	3100	1500	1800	2500	5000	29,615.00	30,518.33
3100 2.0 (180PS) Turbo D S/S auto	8E05 MG8W	1682	1418	3100	1500	1800	2500	4900	33,115.00	34,018.33

S/S = Start/Stop.

Please note: On-the-road recommended retail prices (RRP) include number plates and delivery to Retailer of £583.33 exc. VAT (£700.00 inc. VAT), 12 months' Vehicle Excise Duty (£265.00) and new vehicle first registration fee of £55.00 (correct at time of publication). Excludes fuel and insurance.

All Vivaro models include BlueInjection. Vehicles with BlueInjection technology will need regular AdBlue® top-ups also between servicing requirements. An indicator integrated into the on-board computer will warn you when you need to top up. More information under www.vauxhall.co.uk/blueinjection. In accordance with regulations R (EC) No. 715/2007 and R (EC) No. 692/2008 (in the versions respectively applicable).

Gross plated weights (including axle weights) quoted on the vehicle plate are to UK plated weight specification and must never be exceeded. Unbraked towing weight 750kg – all models.

*Minimum Mass for standard vehicles include coolant, oil and 90% full fuel tank. They will vary according to the vehicle specification (including trim, options and accessories) with a corresponding variation in payload.

VIVARO PANEL VAN PRICES/WEIGHTS

	Pack Code	Minimum Mass (kg)*	Maximum indicative payload (kg)*	Gross Vehicle Weights (GVW) (kg)	Plated weights (kg)		Towing weights (kg) Braked	Plated Gross Combination Weights (GCW) (kg)	Price (£) exc. VAT	On-the-road RRP (£) exc. VAT
					Front axle	Rear axle				
L2 EDITION PANEL VAN EURO 6D TEMP (6.2)										
2900 1.5 (100PS) Turbo D S/S	8C05 i1L1	1770	1060	2830	1500	1800	1400	4230	24,375.00	25,278.33
3100 2.0 (120PS) Turbo D S/S	8C05 MKP1	1685	1415	3100	1500	1800	2500	5000	25,575.00	26,478.33
L2 DYNAMIC PANEL VAN EURO 6D TEMP (6.2)										
2900 1.5 (100PS) Turbo D S/S	8D05 i1L1	1770	1060	2830	1500	1800	1400	4230	25,465.00	26,368.33
3100 2.0 (120PS) Turbo D S/S	8D05 MKP1	1685	1415	3100	1500	1800	2500	5000	26,665.00	27,568.33
3100 2.0 (120PS) Turbo D S/S auto	8D05 MH81	1695	1405	3100	1500	1800	1800	4900	28,465.00	29,368.33
L2 SPORTIVE PANEL VAN EURO 6D TEMP (6.2)										
2900 1.5 (100PS) Turbo D S/S	8D05 i1LX	1770	1060	2830	1500	1800	1400	4230	26,625.00	27,528.33
3100 2.0 (120PS) Turbo D S/S	8D05 MKPX	1685	1415	3100	1500	1800	2500	5000	27,825.00	28,728.33
3100 2.0 (120PS) Turbo D S/S auto	8D05 MH8X	1695	1405	3100	1500	1800	1800	4900	29,625.00	30,528.33
3100 2.0 (150PS) Turbo D S/S	8D05 MLPX	1685	1415	3100	1500	1800	2500	5000	28,925.00	29,828.33
L2 ELITE PANEL VAN EURO 6D TEMP (6.2)										
3100 2.0 (120PS) Turbo D S/S	8E05 MKP1	1685	1415	3100	1500	1800	2500	5000	30,515.00	31,418.33
3100 2.0 (150PS) Turbo D S/S	8E05 MLP1	1685	1415	3100	1500	1800	2500	5000	31,615.00	32,518.33
3100 2.0 (180PS) Turbo D S/S auto	8E05 MG81	1650	1450	3100	1500	1800	2000	4900	34,015.00	34,918.33

S/S = Start/Stop.

Please note: On-the-road recommended retail prices (RRP) include number plates and delivery to Retailer of £583.33 exc. VAT (£700.00 inc. VAT), 12 months' Vehicle Excise Duty (£265.00) and new vehicle first registration fee of £55.00 (correct at time of publication). Excludes fuel and insurance.

All Vivaro models include BlueInjection. Vehicles with BlueInjection technology will need regular AdBlue® top-ups also between servicing requirements. An indicator integrated into the on-board computer will warn you when you need to top up. More information under www.vauxhall.co.uk/blueinjection. In accordance with regulations R (EC) No. 715/2007 and R (EC) No. 692/2008 (in the versions respectively applicable).

Gross plated weights (including axle weights) quoted on the vehicle plate are to UK plated weight specification and must never be exceeded. Unbraked towing weight 750kg – all models.

*Minimum Mass for standard vehicles include coolant, oil and 90% full fuel tank. They will vary according to the vehicle specification (including trim, options and accessories) with a corresponding variation in payload.

VIVARO DOUBLECAB PRICES/WEIGHTS

	Pack Code	Minimum Mass (kg)*	Maximum indicative payload (kg)*	Gross Vehicle Weights (GVW) (kg)	Plated weights (kg)		Towing weights (kg) Braked	Plated Gross Combination Weights (GCW) (kg)	Price (£) exc. VAT	On-the-road RRP (£) exc. VAT
					Front axle	Rear axle				
L1 EDITION DOUBLECAB EURO 6D TEMP (6.2)										
3100 2.0 (120PS) Turbo D S/S	8CF5 MKPW	1752	1308	3060	1500	1800	2500	5000	27,205.00	28,108.33
L2 EDITION DOUBLECAB EURO 6D TEMP (6.2)										
3100 2.0 (120PS) Turbo D S/S	8CF5 MKP1	1770	1170	2940	1500	1800	2500	5000	28,105.00	29,008.33
L2 SPORTIVE DOUBLECAB EURO 6D TEMP (6.2)										
3100 2.0 (120PS) Turbo D S/S	8DC5 MKPX	1770	1170	2940	1500	1800	2500	5000	29,825.00	30,728.33
3100 2.0 (120PS) Turbo D S/S auto	8DC5 MH8X	1805	1215	3020	1500	1800	1800	4820	31,625.00	32,528.33
L2 ELITE DOUBLECAB EURO 6D TEMP (6.2)										
3100 2.0 (120PS) Turbo D S/S	8EC5 MKP1	1770	1170	2940	1500	1800	2500	5000	32,515.00	33,418.33
3100 2.0 (150PS) Turbo D S/S	8EC5 MLP1	1695	1245	2940	1500	1800	2500	5000	33,615.00	34,518.33
3100 2.0 (180PS) Turbo D S/S auto	8EC5 MG81	1741	1259	3000	1500	1800	2000	4900	36,015.00	36,918.33

S/S = Start/Stop.

Please note: On-the-road recommended retail prices (RRP) include number plates and delivery to Retailer of £583.33 exc. VAT (£700.00 inc. VAT), 12 months' Vehicle Excise Duty (£265.00) and new vehicle first registration fee of £55.00 (correct at time of publication). Excludes fuel and insurance.

All Vivaro models include BlueInjection. Vehicles with BlueInjection technology will need regular AdBlue® top-ups also between servicing requirements. An indicator integrated into the on-board computer will warn you when you need to top up. More information under www.vauxhall.co.uk/blueinjection. In accordance with regulations R (EC) No. 715/2007 and R (EC) No. 692/2008 (in the versions respectively applicable).

Gross plated weights (including axle weights) quoted on the vehicle plate are to UK plated weight specification and must never be exceeded. Unbraked towing weight 750kg – all models.

*Minimum Mass for standard vehicles include coolant, oil and 90% full fuel tank. They will vary according to the vehicle specification (including trim, options and accessories) with a corresponding variation in payload.

VIVARO FUEL ECONOMY/EMISSIONS

	NEDC mpg (litres/100km) [#]		WLTP Fuel economy mpg (litres/100km) ^{##}		CO ₂ (g/km) ^{##}	
	Combined	CO ₂ (g/km) [#]	Combined Low	Combined High	High	Low
L1 EDITION PANEL VAN EURO 6D TEMP (6.2)						
2700 1.5 (100PS) Turbo D S/S	57.6 (4.9)	130	38.1 (7.4)	44.8 (6.3)	194	165
2900 1.5 (100PS) Turbo D S/S	56.5 (5.0)	131	38.1 (7.4)	44.8 (6.3)	194	165
3100 2.0 (120PS) Turbo D S/S	52.3 (5.4)	142	35.3 (8.0)	40.3 (7.0)	211	183
L1 DYNAMIC PANEL VAN EURO 6D TEMP (6.2)						
2700 1.5 (100PS) Turbo D S/S	57.6 (4.9)	130	38.1 (7.4)	44.8 (6.3)	194	165
2700 1.5 (120PS) Turbo D S/S	60.1 (4.7)	125	36.5 (7.7)	39.9 (7.1)	177	159
2900 1.5 (100PS) Turbo D S/S	56.5 (5.0)	131	38.1 (7.4)	44.8 (6.3)	194	165
3100 2.0 (120PS) Turbo D S/S	52.3 (5.4)	142	35.3 (8.0)	40.3 (7.0)	211	183
L1 SPORTIVE PANEL VAN EURO 6D TEMP (6.2)						
2700 1.5 (100PS) Turbo D S/S	57.6 (4.9)	130	38.1 (7.4)	44.8 (6.3)	194	165
2700 1.5 (120PS) Turbo D S/S	60.1 (4.7)	125	36.5 (7.7)	39.9 (7.1)	177	159
3100 2.0 (120PS) Turbo D S/S	52.3 (5.4)	142	35.3 (8.0)	40.3 (7.0)	211	183
L1 ELITE PANEL VAN EURO 6D TEMP (6.2)						
3100 2.0 (120PS) Turbo D S/S	52.3 (5.4)	142	35.3 (8.0)	40.3 (7.0)	211	183
3100 2.0 (180PS) Turbo D S/S auto	51.3 (5.5)	145	35.3 (8.0)	40.9 (6.9)	209	183

S/S = Start/Stop.

For fuel economy and CO₂ two sets of data are provided. All engines are validated to emissions standard Euro 6D Temp (6.2) which uses the newer WLTP cycle. This cycle is intended to be a closer representation to economy achieved in the real world and is included for this transparency. NEDC figures are not from the older cycle but in fact are a derived back-correlation calculation from the WLTP test data. Some systems and protocols such as the 2020 CO₂ target will use this figure, and hence it is included for this, and also to enable comparison to outgoing models.

[#]Fuel consumption and CO₂ emission data are determined using the Worldwide harmonised Light vehicles Test Procedure (WLTP), and the relevant values are translated back to allow the comparability into NEDC, according to regulations R (EC) No. 715/2007, R (EU) No. 2017/1153 and R (EU) No. 2017/1151. The values do not take into account in particular use and driving conditions, equipment or options and may vary depending on the format of tyres. For more information on official fuel consumption and CO₂ emission values, please read the guidelines at <http://vanfueldata.dft.gov.uk/>

^{##}Fuel consumption and CO₂ emission data are determined according to the WLTP test cycle. Full data relating to WLTP test cycles can be found at: www.vauxhall.co.uk/wltp

VIVARO FUEL ECONOMY/EMISSIONS

	NEDC mpg (litres/100km) [#]		WLTP Fuel economy mpg (litres/100km) ^{##}		CO ₂ (g/km) ^{##}	
	Combined	CO ₂ (g/km) [#]	Combined Low	Combined High	High	Low
L2 EDITION PANEL VAN EURO 6D TEMP (6.2)						
2900 1.5 (100PS) Turbo D S/S	55.3 (5.1)	135	38.1 (7.4)	44.8 (6.3)	194	165
3100 2.0 (120PS) Turbo D S/S	50.4 (5.6)	148	35.3 (8.0)	40.3 (7.0)	211	183
L2 DYNAMIC PANEL VAN EURO 6D TEMP (6.2)						
2900 1.5 (100PS) Turbo D S/S	55.3 (5.1)	135	38.1 (7.4)	44.8 (6.3)	194	165
3100 2.0 (120PS) Turbo D S/S	50.4 (5.6)	148	35.3 (8.0)	40.3 (7.0)	211	183
3100 2.0 (120PS) Turbo D S/S auto	51.4 (5.5)	144	35.2 (8.0)	39.8 (7.1)	210	186
L2 SPORTIVE PANEL VAN EURO 6D TEMP (6.2)						
2900 1.5 (100PS) Turbo D S/S	55.3 (5.1)	135	38.1 (7.4)	44.8 (6.3)	194	165
3100 2.0 (120PS) Turbo D S/S	50.4 (5.6)	148	35.3 (8.0)	40.3 (7.0)	211	183
3100 2.0 (120PS) Turbo D S/S auto	51.3 (5.5)	146	35.2 (8.0)	39.8 (7.1)	210	186
3100 2.0 (150PS) Turbo D S/S	50.4 (5.6)	147	36.2 (7.8)	41.5 (6.8)	206	180
L2 ELITE PANEL VAN EURO 6D TEMP (6.2)						
3100 2.0 (120PS) Turbo D S/S	50.4 (5.6)	148	35.3 (8.0)	40.3 (7.0)	211	183
3100 2.0 (150PS) Turbo D S/S	50.4 (5.6)	147	36.2 (7.8)	41.5 (6.8)	206	180
3100 2.0 (180PS) Turbo D S/S auto	50.4 (5.6)	147	35.3 (8.0)	40.9 (6.9)	209	183

S/S = Start/Stop.

For fuel economy and CO₂ two sets of data are provided. All engines are validated to emissions standard Euro 6D Temp (6.2) which uses the newer WLTP cycle. This cycle is intended to be a closer representation to economy achieved in the real world and is included for this transparency. NEDC figures are not from the older cycle but in fact are a derived back-correlation calculation from the WLTP test data. Some systems and protocols such as the 2020 CO₂ target will use this figure, and hence it is included for this, and also to enable comparison to outgoing models.

[#]Fuel consumption and CO₂ emission data are determined using the Worldwide harmonised Light vehicles Test Procedure (WLTP), and the relevant values are translated back to allow the comparability into NEDC, according to regulations R (EC) No. 715/2007, R (EU) No. 2017/1153 and R (EU) No. 2017/1151. The values do not take into account in particular use and driving conditions, equipment or options and may vary depending on the format of tyres. For more information on official fuel consumption and CO₂ emission values, please read the guidelines at <http://vanfueldata.dft.gov.uk/>

^{##}Fuel consumption and CO₂ emission data are determined according to the WLTP test cycle. Full data relating to WLTP test cycles can be found at: www.vauxhall.co.uk/wltp

VIVARO FUEL ECONOMY/EMISSIONS

	NEDC mpg (litres/100km) [#]		WLTP Fuel economy mpg (litres/100km) ^{##}		CO ₂ (g/km) ^{##}	
	Combined	CO ₂ (g/km) [#]	Combined Low	Combined High	High	Low
L1 EDITION DOUBLECAB EURO 6D TEMP (6.2)						
3100 2.0 (120PS) Turbo D S/S	52.3 (5.4)	142	35.3 (8.0)	40.3 (7.0)	211	183
L2 EDITION DOUBLECAB EURO 6D TEMP (6.2)						
3100 2.0 (120PS) Turbo D S/S	50.4 (5.6)	148	35.3 (8.0)	40.3 (7.0)	211	183
L2 SPORTIVE DOUBLECAB EURO 6D TEMP (6.2)						
3100 2.0 (120PS) Turbo D S/S	50.4 (5.6)	148	35.3 (8.0)	40.3 (7.0)	211	183
3100 2.0 (120PS) Turbo D S/S auto	49.5 (5.7)	149	35.2 (8.0)	39.8 (7.1)	210	186
L2 ELITE DOUBLECAB EURO 6D TEMP (6.2)						
3100 2.0 (120PS) Turbo D S/S	50.4 (5.6)	148	35.3 (8.0)	40.3 (7.0)	211	183
3100 2.0 (150PS) Turbo D S/S	52.3 (5.4)	143	36.2 (7.8)	41.5 (6.8)	206	180
3100 2.0 (180PS) Turbo D S/S auto	49.5 (5.7)	149	35.3 (8.0)	40.9 (6.9)	209	183

S/S = Start/Stop.

For fuel economy and CO₂ two sets of data are provided. All engines are validated to emissions standard Euro 6D Temp (6.2) which uses the newer WLTP cycle. This cycle is intended to be a closer representation to economy achieved in the real world and is included for this transparency. NEDC figures are not from the older cycle but in fact are a derived back-correlation calculation from the WLTP test data. Some systems and protocols such as the 2020 CO₂ target will use this figure, and hence it is included for this, and also to enable comparison to outgoing models.

[#]Fuel consumption and CO₂ emission data are determined using the Worldwide harmonised Light vehicles Test Procedure (WLTP), and the relevant values are translated back to allow the comparability into NEDC, according to regulations R (EC) No. 715/2007, R (EU) No. 2017/1153 and R (EU) No. 2017/1151. The values do not take into account in particular use and driving conditions, equipment or options and may vary depending on the format of tyres. For more information on official fuel consumption and CO₂ emission values, please read the guidelines at <http://vanfueldata.dft.gov.uk/>

^{##}Fuel consumption and CO₂ emission data are determined according to the WLTP test cycle. Full data relating to WLTP test cycles can be found at: www.vauxhall.co.uk/wltp

FEATURES/OPTIONS

SAFETY

	Option code	Edition	Dynamic	Sportive	Elite	Vivaro-e Dynamic	Vivaro-e Elite	Price (£) exc. VAT	Price (£) inc. VAT
Driver Safety Pack <ul style="list-style-type: none"> • Semi-adaptive cruise control • Forward collision alert with Automatic emergency braking and pedestrian detection • 3.5-inch colour information display • Head-up display (Elite models only) – If ordered on Dynamic and Sportive models in combination with Multimedia Navi Pro, will also include head-up display. 	B26		○	○	●	○	●	990.00	1,188.00
Airbag Driver and front passengers' airbag: <ul style="list-style-type: none"> • Front passengers' airbag with deactivation switch 		●	●	●	●	●	●		
<ul style="list-style-type: none"> • Driver and front passengers' curtain and side-impact airbags, front passenger's airbag with deactivation switch – Standard on Doublecab models. 	AYO	○	○	○	○	○	○	150.00	180.00
Stability Electronic Stability Programme-plus (ESP-plus) with traction control – Works in conjunction with the vehicle's electronic braking and engine systems to keep the vehicle stable in many different situations. ESP monitors a variety of inputs to determine when the vehicle starts to lose traction, it can then immediately respond by varying the brake pressure between up to three wheels and adjust the engine output to help correct the loss of traction and improve stability.		●	●	●	●	●	●		
Tyre pressure <ul style="list-style-type: none"> • Tyre pressure monitoring system 	UJO	○	○	○	○	○	○	50.00	60.00
Braking Four-channel Anti-lock Braking System (ABS) – Prevents the vehicle's wheels from locking up under heavy braking by momentarily reducing brake pressure at the appropriate wheel, ensuring that you can maintain control of the steering. Emergency brake assist – When emergency braking is detected the vehicle Automatically applies the maximum possible braking assistance. Electronic brakeforce distribution – Automatically apportions the optimum braking force to each wheel. Hill start assist – Briefly maintains rear brake pressure to stop the vehicle rolling back on an incline.		●	●	●	●	●	●		

● = Standard equipment. ○ = Optional at extra cost.

FEATURES/OPTIONS

SAFETY CONTINUED

	Option code	Edition	Dynamic	Sportive	Elite	Vivaro-e Dynamic	Vivaro-e Elite	Price (£) exc. VAT	Price (£) inc. VAT
Bulkhead • Full-height steel bulkhead without window – Standard on Panel Van.		●	●			●			
• Full-height ABS plastic bulkhead with window – Doublecab only.				●	●		●		
• Folding bulkhead with integrated steel-framed mesh – Doublecab only.		●							
• Full-height steel bulkhead with window – Panel Van.	AX9	○	○	○	○	○	○	150.00	180.00
FlexCargo load-through bulkhead – Panel Van only • Dual front passengers' seat • Load-through bulkhead	ATM	○	○	●	●	○	●	425.00	510.00

SECURITY

Features • Electronic engine deadlock immobiliser • Steering column lock • Lockable fuel filler cap • Anti-theft spare wheel cradle		●	●	●	●	●	●		
Remote control door locking (features depending on body type) • Remote control door locking • Two keys with integral remote • Door deadlocks • Selective door locking		●	●	●	●	●	●		
Security alarm system • System monitors doors, tailgate, bonnet and the passenger compartment	PS6	○	●	●	●	●	●	170.00	204.00
Keyless open and start • Keyless open and start	ATH		○	○	○	○	○	200.00	240.00

● = Standard equipment. ○ = Optional at extra cost.

FEATURES/OPTIONS

DRIVER ASSISTANCE

	Option code	Edition	Dynamic	Sportive	Elite	Vivaro-e Dynamic	Vivaro-e Elite	Price (£) exc. VAT	Price (£) inc. VAT
Visibility Pack <ul style="list-style-type: none"> Laminated acoustic windscreen Rain-sensitive windscreen wipers Automatic lighting control 	Y74	○	●	●	●	●	●	200.00	240.00
Driver Assistance Pack <ul style="list-style-type: none"> Lane keep assist with lane departure warning Speed sign recognition with intelligent speed adaptation High beam assist Driver drowsiness system White text Instrument panel 	E9A		○	○	●	○	●	320.00	384.00
Multi-function trip computer <ul style="list-style-type: none"> Trip odometer Vehicle range based on remaining fuel Average speed Average fuel economy Instantaneous fuel economy Driving time 		●	●	●	●	●	●		
Parking assistance <ul style="list-style-type: none"> Rear parking distance sensors 	UD7	○	●	●		●		200.00	240.00
<ul style="list-style-type: none"> Front and rear parking distance sensors Side blind spot alert Front fog lights Electrically folding door mirrors 	UD5	○	○	○	●	○	●	400.00	480.00
<ul style="list-style-type: none"> Panoramic rear-view camera – On Edition models, requires rear parking distance sensors (UD7) and Multimedia audio unit (i05) 	UL3	○	○	○	●	○	●	700.00	840.00
Cruise control, speed limiter		●	●	●	●	●	●		
Instrumentation <ul style="list-style-type: none"> Speedometer Rev counter Fuel gauge with low fuel warning light Fuel economy gauge Coolant temperature warning light 		●	●	●	●				
3.5-inch digital instrument cluster						●	●		
Electric parking brake						●	●		
7.4kW single-phase on-board charger with 6m mode-3 22kW cable (added at POE)						●	●		
11kW three-phase on-board charger with mode-3 22kW cable (added at POE)	K29					○	○	300.00	360.00

● = Standard equipment. ○ = Optional at extra cost.

FEATURES/OPTIONS

DRIVER ASSISTANCE CONTINUED

	Option code	Edition	Dynamic	Sportive	Elite	Vivaro-e Dynamic	Vivaro-e Elite	Price (£) exc. VAT	Price (£) inc. VAT
<p>IntelliGrip Pack</p> <p>For those drivers who regularly take their vehicle off-road, this pack helps the driver cope with whatever conditions they encounter. IntelliGrip traction control is designed to increase grip in difficult conditions without the additional weight of a conventional four-wheel drive system.</p> <p>It's an innovative grip control system that provides improved traction on certain terrain and conditions through a combination of optimised torque distribution and limited wheel spin, managed through the electronic stability programme.</p> <ul style="list-style-type: none"> • IntelliGrip: A choice of five selectable modes to suit the driving conditions: ESP on, ESP off, snow, mud, sand - Only available when 17-inch wheels are specified for Edition/Dynamic/Sportive models. 	H4H	○	○	○	○	○	○	660.00	792.00
<p>Worksite Pack</p> <ul style="list-style-type: none"> • Underride protection • Increased ground clearance (+25mm) - Not available on 2700 models or 1.5 (120PS) Turbo D models 	HMG	○	○	○				375.00	450.00

COMFORT

<p>Comfort</p> <ul style="list-style-type: none"> • Reach and rake-adjustable steering wheel • Facia-mounted gear lever • Floor-mounted handbrake lever • Inertia-reel lap and diagonal seatbelts • Height-adjustable outer front seatbelts • Cab headliner – Excludes Doublecab Edition models 		●	●	●	●	●	●		
--------------------------------------------------------------------------------------------------------------------------------------------------------------------------------------------------------------------------------------------------------------------------------------------------------------------------------	--	---	---	---	---	---	---	--	--

FEATURES/OPTIONS

SEATING

	Option code	Edition	Dynamic	Sportive	Elite	Vivaro-e Dynamic	Vivaro-e Elite	Price (£) exc. VAT	Price (£) inc. VAT
Driver's seat • Height • Reach • Backrest recline • Lumbar adjustment • Driver's seat armrest • Padded head restraint		●	●	●	●	●	●		
Dual front passengers' seat with underseat storage • Fixed position bench seat and backrest • Height-adjustable front padded head restraints		●	●	●	●	●	●		
Single front passenger's seat • Reach • Backrest recline • Padded head restraint • Folding backrest • Passenger's seat armrest	AQR		N/C*		N/C	N/C*	N/C	No-cost option	
Seat trim • Curitiba Tritone Grey cloth inert with Carla black vinyl side bolsters – Panel Van.		●	●	●	●	●	●		
• Curitiba Tritone Grey cloth – Doublecab.		●		●	●		●		

REAR SEATING – DOUBLECAB

Doublecab second-row seating • Three-individually contoured rear seats – Not equipped with ISOFIX child seat mountings. • Inertia-reel lap and diagonal seatbelts • Folding seat/upper mesh bulkhead • Padded head restraints		●							
• Three-individually contoured rear seats – Not equipped with ISOFIX child seat mountings. • Inertia-reel lap and diagonal seatbelts • Underseat storage • 12-volt accessory socket • Padded head restraints				●	●		●		

*Special build only, please consult your Retailer for details.

● = Standard equipment. N/C = No-cost option.

FEATURES/OPTIONS

CABIN STORAGE

	Option code	Edition	Dynamic	Sportive	Elite	Vivaro-e Dynamic	Vivaro-e Elite	Price (£) exc. VAT	Price (£) inc. VAT
Facia storage <ul style="list-style-type: none"> • Upper glovebox • Open lower glovebox with 12v socket and aux-in facility • Lower shelf • A4 storage compartment on top of facia • Open storage compartments in facia • Two drinks holders on top of facia • Storage pocket in front of gear lever 		●	●	●	●	●	●		
Front door pockets <ul style="list-style-type: none"> • Three separate compartments in each door 		●	●	●	●	●	●		

INFOTAINMENT

Radio BT Onboard features: <ul style="list-style-type: none"> • AM/FM stereo radio • DAB Digital radio • RDS with Traffic Programme • 20 watts per channel output • Four speakers (eight on Doublecab models) Media connections: <ul style="list-style-type: none"> • USB connection with iPod control • Bluetooth® A2DP audio streaming (Advanced Audio Distribution Profile) Mobile phone portal: <ul style="list-style-type: none"> • Bluetooth® connectivity • Handsfree calls via steering wheel controls • Vehicle microphone 		●							
Multimedia Onboard features: <ul style="list-style-type: none"> • 7-inch colour touchscreen • AM/FM stereo radio with 25 Station presets • DAB Digital radio • RDS with Traffic Programme • 20 watts per channel output • Four speakers (eight on Doublecab models) Media connections: <ul style="list-style-type: none"> • USB connection with iPod control • Bluetooth® A2DP audio streaming (Advanced Audio Distribution Profile) Mobile phone portal: <ul style="list-style-type: none"> • Bluetooth® connectivity • Handsfree calls via steering wheel controls • Vehicle microphone • Phone book access – Contacts/last calls/missed calls etc. are mirrored on the display and are easily navigated using the touchscreen (features dependent on mobile phone) • Bluetooth® connectivity • Handsfree calls via steering wheel controls • Vehicle microphone Smartphone interface: <ul style="list-style-type: none"> • Apple CarPlay™ • Android Auto™ – Smartphone projection that allows operations via voice command, touchscreen and buttons to control apps and music playback. 	i05	○	●	●		●		400.00	480.00

● = Standard equipment. ○ = Optional at extra cost.

FEATURES/OPTIONS

INFOTAINMENT CONTINUED

	Option code	Edition	Dynamic	Sportive	Elite	Vivaro-e Dynamic	Vivaro-e Elite	Price (£) exc. VAT	Price (£) inc. VAT
<p>Multimedia Navi Pro</p> <p>Onboard features:</p> <ul style="list-style-type: none"> • 7-inch colour touchscreen • AM/FM stereo radio with 15 Station presets • DAB Digital radio • RDS with Traffic Programme • 20 watts per channel output • Four speakers (eight on Doublecab models) <p>Navigation features:</p> <ul style="list-style-type: none"> • Satellite navigation system • 3D street level mapping • European coverage • Structured or one-box destination entry • Points-of-interest search • Eco routing • Map updates via USB <p>Wi-fi enabled connected navigation features:</p> <ul style="list-style-type: none"> • Three years subscription to TomTom Live* • On-line navigation services provided by TomTom® include: • TomTom® live traffic updates • Local weather information • Nearby fuel station display • Local address search and contact info for points of interest <p>Media connections:</p> <ul style="list-style-type: none"> • USB connection with iPod control • Bluetooth® A2DP audio streaming (Advanced Audio Distribution Profile) <p>Mobile phone portal:</p> <ul style="list-style-type: none"> • Bluetooth® connectivity • Handsfree calls via steering wheel controls • Vehicle microphone • Phone book access – Contacts/last calls/missed calls etc. are mirrored on the display and are easily navigated using the touchscreen (features dependent on mobile phone). <p>Smartphone interface:</p> <ul style="list-style-type: none"> • Apple CarPlay™ • Android Auto™ – Smartphone projection that allows operations via voice command, touchscreen and buttons to control apps and music playback. <p>Vivaro-e shortcut key:</p> <p>Provides dedicated shortcut key for LEV-specific pages:</p> <ul style="list-style-type: none"> • Energy flow visualization • Energy stats visualization • Deferred charging options • Thermal pre-conditioning • Battery/range check 	i06		○	○	●	○	●	250.00	300.00
<p>Additional features</p> <ul style="list-style-type: none"> • Steering column mounted audio controls • Flexible roof-mounted aerial 		●	●	●	●	●	●		
<p>Vauxhall Connect</p>		●	●	●	●	●	●		

*Additional terms and conditions apply to connected services, including customer acceptance of location sharing prior to activation.

● = Standard equipment. ○ = Optional at extra cost.

FEATURES/OPTIONS

INFOTAINMENT CONTINUED

	Option code	Edition	Dynamic	Sportive	Elite	Vivaro-e Dynamic	Vivaro-e Elite	Price (£) exc. VAT	Price (£) inc. VAT
<p>e-Call and b-Call: Help when you need it, 24/7, 365 days a year, that's what you get with new Vauxhall Connect. In an emergency or breakdown, you'll be put in touch with a trained advisor, with just the touch of a button.</p> <p>Live navigation and more: You can also access live navigation services, receive regular vehicle diagnostic info plus there's a host of remote convenience features available through the MyVauxhall app.**</p> <p>Peace of mind:</p> <ul style="list-style-type: none"> • Emergency call, breakdown call and regular vehicle status and information • Convenience: remote functions (e.g. lock/unlock the door) • Our additional services for Vivaro-e: trip planning, remote settings or public charging solutions – we keep you going! <p>Smart driving:</p> <ul style="list-style-type: none"> • Enjoy a relaxed ride thanks to live navigation** and trip management 		●	●	●	●	●	●		

**Services may require a subscription/fee and are subject to mobile network coverage and availability. Live navigation services are included for 3 years and thereafter are subject to an additional subscription fee.

● = Standard equipment.

FEATURES/OPTIONS

HEATING AND VENTILATION

	Option code	Edition	Dynamic	Sportive	Elite	Vivaro-e Dynamic	Vivaro-e Elite	Price (£) exc. VAT	Price (£) inc. VAT
Air conditioning • Air recirculation facility • Pollen filter • Illuminated controls • Chilled glovebox facility	C60	○	●	●	●	●	●	800.00	960.00
Electronic climate control • LCD temperature display • Automatic air direction and fan speed with manual override • Illuminated controls • Pollen filter • Chilled glovebox facility	CJ2		○	○	○	○	○	500.00	600.00

LOAD ACCESS

Side access – Panel Van only Nearside and offside side-access door: • Nearside sliding side-access door • Offside sliding side-access door • Unglazed		●	●	●	●	●	●		
Nearside and offside access Nearside and offside side-access door with fixed windows – Standard on Doublecab: • Fixed window to nearside side-access door • Fixed window to offside side-access door	8P9	○	○	○	○	○	○	100.00	120.00
Nearside and offside side-access door with sliding windows – Doublecab only: • Sliding window to nearside side-access door • Sliding window to offside side-access door	5B0	○						650.00	780.00
Handsfree electrically operated sliding side-access doors – Panel Van only. • Keyless open and start • Auto anti-dazzle rear-view mirror	DFO		○	○	○	○	○	1,125.00	1,350.00
Rear access Rear solid doors: • Twin rear doors • 90°/180° opening		●	●	●	●	●	●		
Rear glazed doors: • Glazed rear doors • 90°/180° opening • Heated rear windows with wash/wipe facility	J1X	○	○	○	○	○	○	200.00	240.00
Tailgate: • Glazed tailgate • Heated rear windows with wash/wipe facility	J1U	○	○	○	○	○	○	200.00	240.00

● = Standard equipment. ○ = Optional at extra cost.

FEATURES/OPTIONS

LOAD RESTRAINT

	Option code	Edition	Dynamic	Sportive	Elite	Vivaro-e Dynamic	Vivaro-e Elite	Price (£) exc. VAT	Price (£) inc. VAT
Load anchorage • Fixed floor-mounted load restraint lashing eyes – Six on L1 and 8 on L2 models.		●	●	●	●	●	●		
Load lining • 9mm untreated wooden load floor – Panel Van only. Not available when tailgate option(s) are specified.	CRJ	○	○	○	○	○	○	180.00	216.00
• 6mm untreated wooden load side and wheel arch lining – Panel Van only. Not available when tailgate option(s) are specified. Includes 9mm wooden load floor (CRJ).	ERK	○	○	○	○	○	○	480.00	576.00
• 9mm coated anti-slip wooden load floor with aluminium rails – Standard on Edition Doublecab models.	CR1	○	○	○	○	○	○	225.00	270.00
• 6mm coated wooden load side and wheel arch lining – Not available on Edition Doublecab models. Includes 9mm coated wooden load floor (CR1).	ERO	○	○	○	○	○	○	625.00	750.00

EXTERIOR LIGHTING

Standard lighting • Lights-on audible warning • Reversing lights • Hazard warning lights • Rear fog lights • High-level brake light • Side-repeat indicators • Daytime running lights – LED on Sportive/Elite models.		●	●	●	●	●	●		
Front fog lights			●	●	●	●	●		

EXTERIOR CONVENIENCE/STYLING

Appearance Pack • Body-colour front bumper • Body-colour rear bumper (L1 models only) • Body-colour rear corner bumper with black centre section (L2) • Body-colour mirror housings and door handles • Body-colour side-protection mouldings • Chrome-effect front grille • LED daytime running lights				●	●		●		
Windows • Electrically operated front windows with one-touch up/down facility		●	●	●	●	●	●		
Door mirrors • Foldable electrically adjustable/heated door mirrors		●	●	●	●	●	●		

● = Standard equipment. ○ = Optional at extra cost.

FEATURES/OPTIONS



MECHANICAL

	Option code	Edition	Dynamic	Sportive	Elite	Vivaro-e Dynamic	Vivaro-e Elite	Price (£) exc. VAT	Price (£) inc. VAT				
Transmission Six-speed manual gearbox: • Front-wheel drive • Transverse engine/gearbox		●	●	●	●								
Eight-speed Automatic transmission • Front-wheel drive • Transverse engine/gearbox Replacing the traditional lever, the Automatic transmission selection-mode dial/drive wheel is an innovation solution that is both elegant and intuitive. By simply twisting the dial, the following modes can be selected: • Park, for when the vehicle is stationary and the wheels are locked • Drive, for Automatic forward motion • Neutral, for when the vehicle is stationary, wheels are free • Reverse, for Automatic backward motion For an extra experience of dynamism, the shift paddles for Automatic transmissions are located behind the steering wheel, offering drivers an extra level of control that is highly ergonomic and intuitive. The shift paddles function in the following way: • To go up a gear, the driver must pull the right lever towards themselves • To go down a gear, the driver must pull the left lever towards themselves – Please note: only consecutive gear changes are possible.		▲	▲	▲	▲								
Steering • Hydraulic power-assisted rack and pinion system • Energy absorbing steering column		●	●	●	●								
Turning circles <table border="1" style="display: inline-table; margin-left: 20px;"> <thead> <tr> <th></th> <th>Kerb-to-kerb</th> </tr> </thead> <tbody> <tr> <td>L1/L2</td> <td>12.4m (40.7ft.)</td> </tr> </tbody> </table>		Kerb-to-kerb	L1/L2	12.4m (40.7ft.)		●	●	●	●				
	Kerb-to-kerb												
L1/L2	12.4m (40.7ft.)												
Brakes Front ventilated disc brakes: • 304mm x 28mm Rear disc brakes: • 290mm x 12mm		●	●	●	●								
Fuel tank • 70 litres (15.4 gallons) capacity		●	●	●	●								

● = Standard equipment. ▲ = See price page for details.

FEATURES/OPTIONS

MECHANICAL CONTINUED

	Option code	Edition	Dynamic	Sportive	Elite	Vivaro-e Dynamic	Vivaro-e Elite	Price (£) exc. VAT	Price (£) inc. VAT
AdBlue® tank • 22.5 litres (4.95 gallons) capacity		●	●	●	●				
CANbus interface	WRF	○	○	○	○			90.00	108.00
 Tow bar (Retailer-fit for Vivaro-e) • Heavy duty removable towing hook with tool (ball and hook) • Provision for tow bar • Towing connector	8PI	○	○	○	○			400.00	480.00
 Tow bar (Retailer-fit for Vivaro-e) • Removable monoblock towing ball with tool (ball) • Provision for tow bar • Towing connector	V76	○	○	○	○			300.00	360.00
 Tow bar (Retailer-fit for Vivaro-e) • Removable monoblock towing ball without tool • Provision for tow bar • Towing connector	VQ9	○	○	○	○			400.00	480.00

● = Standard equipment. ○ = Optional at extra cost.

NEW VIVARO-E SPECIFICATIONS

TRANSMISSION

	Vivaro-e Dynamic	Vivaro-e Elite
<p>Single-speed electronic drive selector</p> <p>All-electric single speed drive means there is no need for multiple gears. Instead the e-toggle enables the driver to select from the following:</p> <ul style="list-style-type: none"> • Park • Reverse • Neutral • Drive • Braking – for increased regenerative braking 	●	●
<p>Drive mode selector</p> <p>The driver can determine the driving style through selecting one of the following modes:</p> <ul style="list-style-type: none"> • Power (136PS) – increased performance for use when transporting heavier loads • Normal (107PS) – optimised performance for normal daily use • Eco – (80PS) tailored to provide the lowest energy consumption 	●	●
<p>Energy recuperation</p> <p>The regenerative braking system works when the van is in motion, energy created by the resistance of the brakes against the drivetrain is converted into DC voltage to partially recharge the battery. The driver can also engage braking mode through the drive selector to increase the level of energy recuperation.</p> <p>Single foot driving experience</p> <p>The system not only utilises the energy when the brakes are being used, but also engages when the vehicle is coasting, recovering more energy and enabling single foot driving as the brakes automatically engage when the throttle pedal is released.</p>	●	●











EXTERIOR COLOURS

Solid		Jade White (G2o)	●	●	●	●	●	●	●				
	VX_COL_White_Jade_G2o												
Two-coat		Moonstone Grey metallic (G4o)											
	VX_COL_MoonstoneGrey_G4o												
		Quartz Silver metallic (G4i)	○	○	N/C	N/C	○	N/C	500.00	600.00			
VX_COL_QuartzSilver_G4i													
	Diamond Black metallic (G7o)												
VX_COL_DiamondBlack_G7o													

The colours reproduced may vary slightly from the actual paint colour. As a result they should be used as a guide only. Your Vauxhall Retailer has a comprehensive display of our paint samples.

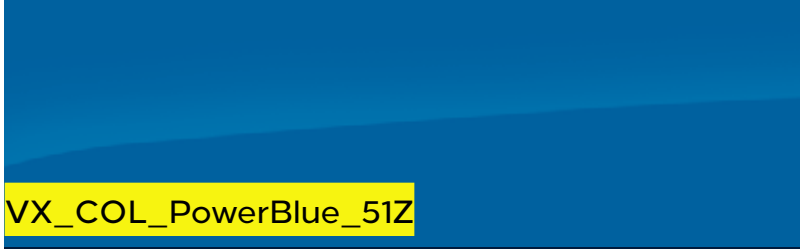
● = Standard equipment. ○ = Optional at extra cost. N/C = No-cost option.

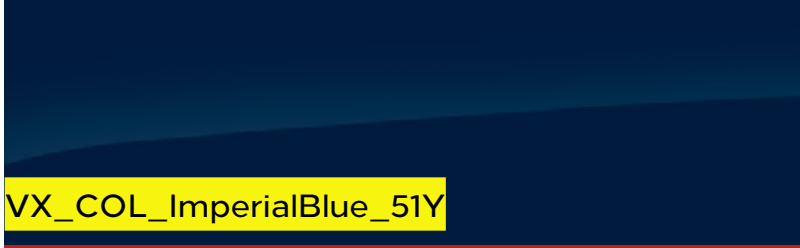
SPECIAL COLOURS



				Edition	Dynamic	Sportive	Elite	Vivaro-e Dynamic	Vivaro-e Elite	Price (£) exc. VAT	Price (£) inc. VAT	
Special Colours		Post Yellow (GV4) VX_COL_PostYellow_51P		Golden Yellow (GRU/RAL 1004) VX_COL_GoldenYellow(RAL1004)_51A								
		Post Red (GHU) VX_COL_PostRed_51T		Flaming Red (GEO) VX_COL_FlameRed_79U								
		Genet Yellow (GRT/RAL 1032) VX_COL_GenetYellow(RAL1032)_51B		Beige Tropic (GCL/RAL 1015) VX_COL_Beige Tropic _GCL								
		Power Blue (GRP) VX_COL_PowerBlue_51Z		Sky Blue Centrica (GRV) VX_COL_Centrica_Blue_GRV	○	○			○		800.00	960.00
		Imperial Blue (GIB) VX_COL_ImperialBlue_51Y		Squid Ink Grey (23U) VX_COL_Squid_Ink_Grey_23U								
		Fire Red (GRR/RAL 3000) VX_COL_FireRed(RAL3000)_51Q										

Additional lead-time for special paint will be confirmed at order placement (event 25). Consult Retailer for details.

The colours reproduced may vary slightly from the actual paint colour. As a result they should be used as a guide only. Your Vauxhall Retailer has a comprehensive display of our paint samples.



○ = **Optional at extra cost.**

WHEELS AND TYRES

	Option code	Edition	Dynamic	Sportive	Elite	Vivaro-e Dynamic	Vivaro-e Elite	Price (£) exc. VAT	Price (£) inc. VAT
Full-size spare wheel		●	●	●	●	●	●		
All-season tyres • 215/65 R 17 – Only available when 17-inch wheels are specified.	Q40	○	○	○	○			200.00	240.00
Tyre inflation kit in lieu of spare wheel	KTi	N/C	N/C	N/C	N/C	N/C	N/C	No-cost option	
 16-inch steel wheels with centre cap • 215/65 R 16 tyres		●							
 16-inch steel wheels with full-diameter wheel trims • 215/65 R 16 tyres			●	●		●			
 17-inch silver alloy wheels • 215/60 R 17 tyres • Locking wheel bolts	RVF		○	○	●		●	400.00	480.00

● = Standard equipment. ○ = Optional at extra cost. N/C = No-cost option.

WHEELS AND TYRES

	Option code	Edition	Dynamic	Sportive	Elite	Vivaro-e Dynamic	Vivaro-e Elite	Price (£) exc. VAT	Price (£) inc. VAT
 <p>17-inch steel wheels with centre cap • 215/60 R 17 tyres</p> <p>VX_VIV_29656</p>	RS9	○						120.00	144.00
 <p>17-inch steel wheels with full-diameter wheel trims • 215/60 R 17 tyres</p> <p>VX_VIV_29657</p>	RVE		○	○				200.00	240.00

○ = Optional at extra cost.

DIESEL ENGINES

Engine	1.5 (100PS) Turbo D Start/Stop BlueInjection	1.5 (120PS) Turbo D Start/Stop BlueInjection	2.0 (120PS) Turbo D Start/Stop BlueInjection
Capacity	1499cc	1499cc	1997cc
Maximum power	100PS (75kW) @ 3500rpm	120PS (88kW) @ 3500rpm	120PS (88kW) @ 3500rpm
Maximum torque	270Nm (184 lb.ft.) @ 1600rpm	300Nm (221 lb.ft.) @ 1750rpm	340Nm (251 lb.ft.) @ 2000rpm
Configuration	4 cylinders, 4 valves per cylinder, double overhead camshafts	4 cylinders, 4 valves per cylinder, double overhead camshafts	4 cylinders, 4 valves per cylinder, double overhead camshafts
Emission compliance	Euro 6D TEMP (6.2)	Euro 6D TEMP (6.2)	Euro 6D TEMP (6.2)
Service interval	25,000 miles or 2 years (whichever occurs sooner)	25,000 miles or 2 years (whichever occurs sooner)	30,000 miles or 2 years (whichever occurs sooner)

Engine	2.0 (150PS) Turbo D Start/Stop BlueInjection	2.0 (180PS) Turbo D Start/Stop BlueInjection
Capacity	1997cc	1997cc
Maximum power	150PS (110kW) @ 3500rpm	180PS (130kW) @ 3500rpm
Maximum torque	370Nm (273 lb.ft.) @ 2000rpm	400Nm (295 lb.ft.) @ 2000rpm
Configuration	4 cylinders, 4 valves per cylinder, double overhead camshafts	4 cylinders, 4 valves per cylinder, double overhead camshafts
Emission compliance	Euro 6D TEMP (6.2)	Euro 6D TEMP (6.2)
Service interval	30,000 miles or 2 years (whichever occurs sooner)	30,000 miles or 2 years (whichever occurs sooner)

NEW VIVARO-E DRIVETRAIN

DRIVETRAIN

BATTERY ENERGY KWH	50	75
location	under load floor – no impact to loading volume	
CO ₂ emissions	0g/km	0g/km
EV range (WLTP Combined) miles*	143	205
Maximum power PS/kW	136/100	136/100
Maximum torque Nm/lb.ft	260/192	260/192
Maximum speed mph	81	81
Acceleration 0-62mph seconds	13.1	14.3
Battery warranty	8 years 100,000 miles/70% capacity	
Service interval	Initial inspection at 12,500 miles/1 year (whichever comes sooner). Main service at 25,000 miles/2 year (whichever comes sooner)	

Please note, EV range assumes that vehicle has been pre-conditioned prior to journey. This function can be accessed either via MyVauxhall App (standard with all Vivaro-e) or by using the Multimedia Navi Pro infotainment system (standard on Elite and optional on Dynamic).

CHARGING**

Supply	AC Current		DC Current	
	Domestic 8amp	Wallbox 32amp Single-phase	Wallbox 16amp Three-phase	Rapid charge [†] 0-80%
	1.8kWh	7.4kWh	11.kWh ^{††}	100kWh
50kWh battery	28h	7h 30m	4h 45m	30m
75kWh battery	42h	11h 20m	7h	45m

The Vivaro-e is fitted with a 7.4kW on-board charger as standard together with a Mode 3 7kW 6m charging cable. An 11kW on-board charger is available as an extra cost option.

The charging flap's Padlock LED lights up when the cable is correctly plugged in and locked and then acts as a user interface to show the charging status via coloured LED lights:

- White – welcome light that helps to light up the area, especially useful in dark conditions
- Flashing green – charging in progress
- Solid green – charging complete
- Solid blue – delayed charging toggled; changes to flashing green when charging commences
- Solid red – malfunction

The driver may also choose from two settings:

- Immediate charging (the standard setting) – starts charging as soon as the vehicle is docked for charging
- Delayed charging – this is especially useful for when cheaper electric rates are desired, e.g. charging at night. Simply enter a charging start time

The Vivaro-e is a battery electric vehicle requiring mains electricity for charging. Range data given has been determined according to WLTP test procedure methodology. The figures shown are intended for comparability purposes only and should only be compared other cars tested to the same technical standard. The range you achieve under real world driving conditions will depend upon a number of factors, including but not limited to: the accessories fitted (pre and post registration); charging frequency; personal driving style; vehicle payload and route characteristics; variations in weather; heating/air conditioning; pre-conditioning and battery condition. For more information, contact your local Vauxhall Retailer.

*WLTP figure includes 50% payload. Please note, EV range is achieved in 'normal' mode. 'Power' mode will decrease range and 'Eco' mode will extend range although power, torque and climate control are limited.

**Provisional data.

[†]You can obtain 0-80% of the vehicle charge in as low as 32 minutes from a 100kW rapid charging station. Rapid charging stations are widely available across the UK at various locations and their power rating varies, typically from 50kW and sometimes up to 350kW. The charging time may vary according to the type and power of the charging station, the outside temperature at the charging point and the battery temperature.

^{††}With optional 11kWh on-board charger.

DIMENSIONS

Loadspace Dimensions	L1	L2
Maximum length at load floor – Panel Van	2512 (98.9)	2862 (112.7)
Mid-height load length – Panel Van	2185 (86.0)	2535 (99.8)
Maximum length with load-through facility maximum length to front footwell – Panel Van	3674 (144.6)	4024 (158.4)
Maximum length at load floor – Doublecab	2017 (79.4)	2365 (93.1)
Mid-height load length behind rear seats – Doublecab	1352 (53.3)	1700 (66.9)
Maximum length at load floor – Doublecab with folding bulkhead (bench seat down)	2018 (79.5)	2367 (93.2)
Maximum length at load floor – Doublecab with folding bulkhead (bench seat folded up)	2029 (79.9)	2376 (93.5)
Maximum width	1636 (64.4)	1636 (64.4)
Width between wheel arches	1258 (49.5)	1258 (49.5)
Maximum height	1397 (55.0)	1397 (55.0)

Loadspace Access millimetres (inches)	L1	L2
Side door aperture height	1241 (48.8)	1241 (48.8)
Side door aperture width	935 (36.8)	935 (36.8)
Rear door aperture height	1220 (48.0)	1220 (48.0)
Rear door aperture width	1282 (50.5)	1282 (50.5)
Loading height – Maximum	613 (24.1)	633 (24.9)
Loading height – Minimum	544 (21.4)	600 (23.6)
Loadspace Volumes cu.m (cu.ft.)		
Panel Van	5.3 (187.2)	6.1 (215.4)
Panel Van with load-through facility	5.8 (204.8)	6.6 (233.1)
Doublecab	3.2 (113.0)	4.0 (141.3)
Doublecab with folding bulkhead	4.7 (166.0)	5.5 (194.2)

EXTERIOR DIMENSIONS

All measurements are in mm (inches) unless stated otherwise.

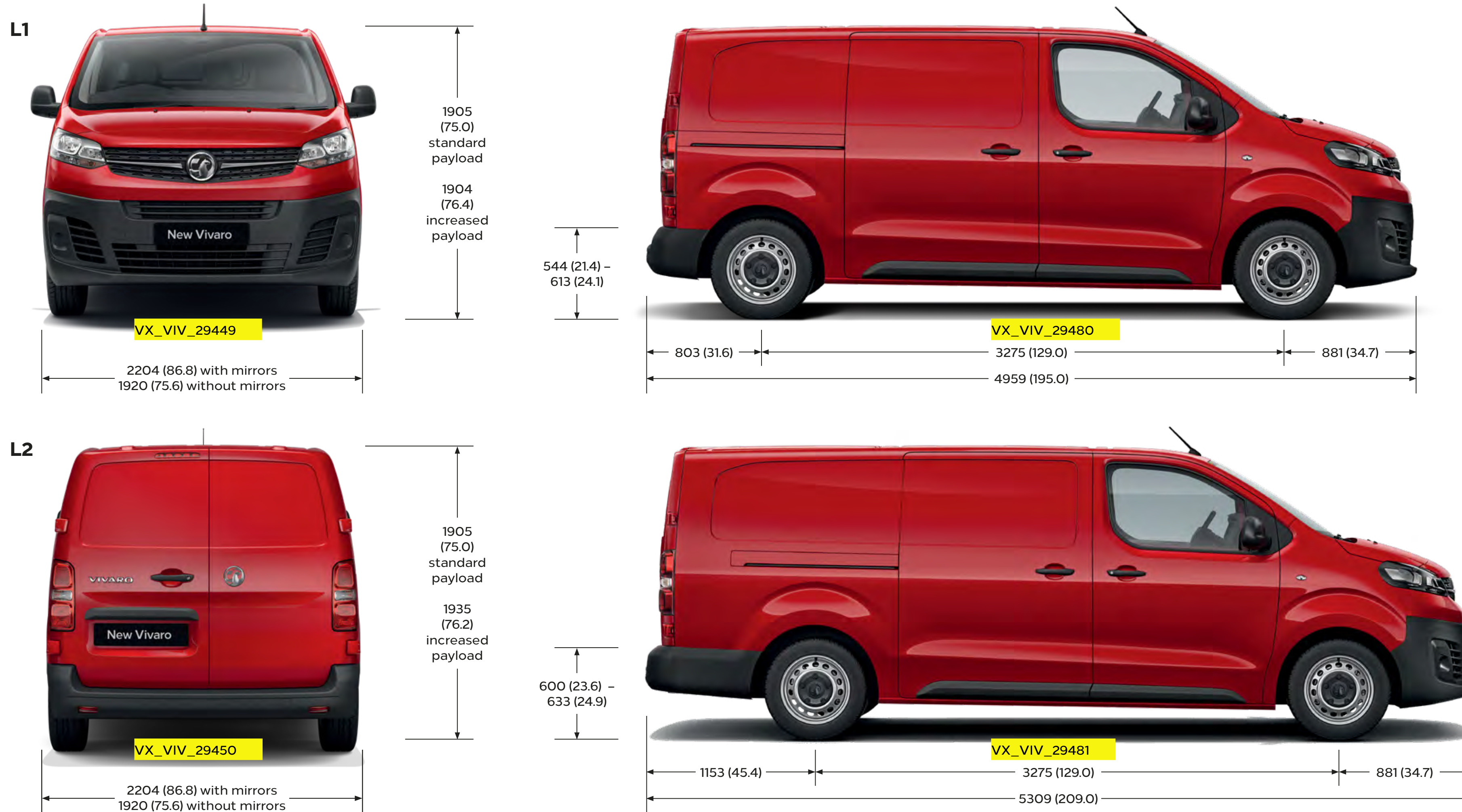

Vivaro-e is the same dimensions as Vivaro with following differences only:

- Ground clearance + 20 mm versus diesel models
- Loading sill height @ kerbweight is similar to diesel models
- Loading sill height @ GVW + 20 mm versus diesel models

ACCESSORIES

SAFETY	Total (exc. VAT)	INTERIOR PROTECTION	Total (exc. VAT)	TRANSPORT SYSTEMS	Total (exc. VAT)	CHARGING	Total (exc. VAT)
Safety kit (first aid kit, hi-vis vest and warning triangle)	£13	Wooden floor protection – 2 sliding doors		Aluminium roof bar single (2 or 3 needed)	£107	Mode 2 emergency charging cable – Type G	£487
Warning triangle	£7	– L1	£288	Steel roof rack		Mode 3 charging cable 7.4kW	£276
First aid kit	£12	– L2	£299	– L1	£1,078	Mode 3 charging cable 11kW	£309
Hi-vis safety vest – Adult	£3	– L3	£322	– L2	£1,160	Mode 3 charging cable 22kW	£365
Emergency seat belt cutter and hammer	£15	Wooden interior side protection – 2 sliding doors		– L3	£1,244	Cable bag – Mode 2/3	£41
Philips ADR620 dash cam	£90	– L1	£324	Aluminium roof rack		Mode 2 universal charger UK kit 22kW	£1,296
Front Foglamps Kit	£443	– L2	£369	– L1	£1,522	Universal charger – Wall bracket	£88
		– L3	£382	– L2	£1,693	Universal charger bag	£54
PRACTICAL		Wooden wheel arch protection		– L3	£1,792	Universal charger – Safety lock	£17
Wind deflectors	£65	– L1/L2/L3	£86	Rear door aluminium ladder	£258	Universal charger – Adapter type 2	£265
Smokers pack	£42	Premium wooden floor protection – 2 sliding doors		Roof Carriers		Universal charger – Adapter type 3c	£298
Fragrance diffuser	£19	– L1	£304	Thule ladder tilt 311	£498	Universal charger – Adapter (various)	£100
Fragrance cartridge	£14	– L2	£333	Thule ladder holder 330	£116		
USB charger – 2 front and 2 rear ports	£22	– L3	£371	Thule ladder roller 335	£75		
		Premium wooden interior side protection – 2 sliding doors		Thule front load stop system (side profiles)	£168	TOWING	
SECURITY		– L1	£376	Thule front load stop system 321 (front)	£79	Tow bar with removable tow ball ³	£375
Alarm system ¹	£361	– L2	£388	Thule ratchet tie down strap	£25	Tow bar with removable swan's neck tow ball ³	£266
Anti-lift module for alarm system	£115	– L3	£452	Thule fold down load stop 315	£50	Tow bar without tow ball ³	£266
VHF volumetric sensor for alarm system	£133	Premium wooden wheel arch protection		Thule square bar adapter	£37		
		– L1/L2/L3	£98				
PROTECTION		Polypro floor protection – 2 sliding doors					
Rubber front floor mat	£67	– L1	£362				
Seat covers		– L2	£391				
– Driver seat and single passenger seat	£139	– L3	£429				
Splash guards – Front	£51	Polypro Interior side protection – 2 sliding doors					
Splash guards – Rear ²	£53	– L1	£376				
Rear bumper protector ²	£30	– L2	£388				
Front parking sensors ²	£313	– L3	£452				
Rear parking sensors	£327	Polypro wheel arch protection					
		– L1/L2/L3	£98				

Please note: Prices shown are fully fitted and painted, where applicable and exclude VAT. Please check with your local Vauxhall Retailer for details. It is advisable to ensure your insurance policy is adequate to cover additional fitted accessories. Prices correct at time of publication.

¹Additional parts may be required for fitting alarm system dependent on model. Please consult your local Vauxhall Retailer for details. ²Excludes L1. ³Additional fixing kit required for platform cab vehicles.

GLOSSARY OF TERMS

Plated weight

The maximum weight to which a vehicle or an axle may be loaded, determined either by the design of the components or by legislation. All commercial vehicles must carry a manufacturer's 'plate' showing the vehicle and axle gross 'plated weights'. It is an offence to drive a vehicle in a condition where any of these weights are exceeded.

Minimum Mass

Minimum Mass ('Mass in running order' on Certificate of Conformity and 'Mass in Service' on V5C form) is defined according to European Type Approval and include all fluids, tools and 90% fuel load. It is minimum mass for this variant and does not consider local specification/trim or deletable options (specific to Movano). Weights are also subject to manufacturing tolerances (EU Legislation allows 5% tolerance).

Gross Vehicle Weight (GVW)

The total permissible weight of a vehicle including payload and passengers, as shown on the manufacturer's plate.

Gross Combination Weight (GCW)

The maximum permissible weight of a vehicle, including payload and passengers, combined with the total weight of any trailer it is towing. The maximum GCW weight limit is quoted on the vehicle plate and must not be exceeded.

Payload

The total permissible weight that can be carried without exceeding the vehicle's plated weight. Payload do not include driver but do take into consideration specification/trim level:

Weights are also subject to manufacturing tolerances (EU Legislation allows 5% tolerance). Payload does not consider any additional options that a customer may order.

Roof loads

- Combo roof load should not exceed 100kg including the weight of the roof rack/carrier
- Vivaro roof load should not exceed 170kg including the weight of the roof rack/carrier
- Movano roof load should not exceed 200kg (150kg on H1 models) including the weight of the roof rack/carrier. H3 are not permitted to carry roof loads

Maximum towing weight

The maximum weight of any trailer and its load which may be towed within the limit of the vehicle's plated Gross Combination Weight (GCW). It is based on the ability of the vehicle – at full GCW – to restart on a 12% gradient, which is approximately 1 in 8.3, at sea level. At altitudes above 1500 metres, the engine output may drop with a corresponding reduction in towing capability. It is the operator's responsibility to ensure that the trailer noseweight does not cause the rear axle plated weight of the towing vehicle to be exceeded.

Always fit Vauxhall towing attachments and accessories available from your Vauxhall Commercial Vehicle Retailer. They are designed specifically for Vauxhall models and carry a 12-month warranty.

Light Duty and Heavy Duty cycles

For a Light Duty cycle (EC regulation 715/2007 with designation 'Euro 6') the emissions of the whole vehicle are evaluated whereas for Heavy Duty cycle (EC regulation 595/2009 with designation 'Euro VI') only the engine is bench tested. The requirement of which cycle is necessary is determined by the reference mass of the vehicle. In the case of Movano, reference mass calculations dictate that:

- N1 FWD and M1 FWD are approved as Light Duty
- N1 RWD, N2 RWD and M2 FWD are approved as Heavy Duty

Conversions

With Vivaro a new conversion portal is introduced. This significantly improves the transparency and response of all communication with body-builders, and converters:

www.converters-and-groupe-psa.com

This website contains complete technical guidelines necessary to convert Vauxhall commercial vehicles – Combo (K9), Vivaro (K0) and Movano (X62). All vital and fundamental information is now located in one place:

- Conversion Guidelines
- Technical Data
- 3D CAD (coming)
- WLTP guidance
- Body shell ordering

Additionally there is a new Q&A service for technical questions, and the new conversion approval process will also be managed through this portal.

Any converter of Vauxhall product should create an account on this portal including those using IVA as approval process. In fact WLTP will make this necessary.

Commercial Vehicle Categories

Differences between M1/N1 and M2/N2 (Vehicles with GVW above 3500kg)

Category M: Passenger carriers

Category M1: Vehicles designed and constructed for the carriage of passengers and comprising no more than eight seats in addition to the driver's seat.

Category M2: Vehicles designed and constructed for the carriage of passengers, comprising more than eight seats in addition to the driver's seat, and having a maximum mass not exceeding 5 tonnes.

Category N: Goods vehicles

Category N1: Vehicles designed and constructed for the carriage of goods and having a maximum mass not exceeding 3.5 tonnes.

Category N2: Vehicles designed and constructed for the carriage of goods and having a maximum mass exceeding 3.5 tonnes but not exceeding 12 tonnes.

Specific differences, all M2/N2 require the following:

Speed limiter: All M2/N2 vehicles are legally required to be speed limited. M2 to 62mph and N2 to 56mph.

GLOSSARY OF TERMS

Driver licence: Commercial vehicles with GVW greater than 3.5 tonnes have different license requirements. For any new drivers C1 category is necessary. Under some circumstances (social purposes for a non-commercial body) it is possible to drive a minibus without a D1 entitlement (Minibus) however eligibility for this exemption should be confirmed with DVSA.

Driver CPC: Driver Certificate of Professional Competence mandates 35 hours of periodic training every 5 years to maintain licence (from September 2014).

Tachograph: It is a legal requirement to administer the activities of drivers subject to the EU or AETR drivers' hours rules, and also record the vehicle's speed, distance and time. A Smart Card is required for digital tachograph and these are available from the DVLA. The tachograph of a new vehicle must be calibrated within two weeks of first registration.

Operator's Licence: This may also be required to ensure that vehicles are kept safe and in good condition at all times. Specifically for M2, PSV (public service vehicle) operator's licence is required. Exemptions in some circumstances may be permitted but this should always be confirmed with DVSA.

MOT Testing: M2/N2 must be tested each year, and vehicle presented with a completed Certificate of Conformity (CoC). This is available from Vauxhall (regdata@gm.com) or from converter in case of second-stage conversion.

Conversions - WLTP

There is a mandatory CO₂ target that comes into effect in 2020. There are specific targets for both cars and light commercial vehicles. With respect to LCVs, Vauxhall will be responsible for the CO₂ of complete converted vehicle, and defined Maxi-Pollutant Values must be respected.

These values are:

- Mass in Running Order (kg)
- Frontal Surface (m²)
- Rolling Resistance Coefficient of tyres (kg/t)
- Air Inlet Surface to cool the engine (dm²)

Conversion Guidelines; Maxi-Pollutant Values and links to CO₂ calculator can all be found on the converter portal at www.converters-and-groupe-psa.com

Second-stage conversions based on a Euro 6D TEMP engine cannot be registered unless they have passed the CO₂ calculator. If Maxi-Pollutant values are not followed, then CO₂ calculation will fail and converted vehicle cannot be registered. It would be necessary then to change the conversion.

FURTHER INFORMATION

Vauxhall on-the-road recommended retail prices (RRP)

To eliminate uncertainty about hidden costs incurred when buying a new commercial vehicle, Vauxhall publishes on-the-road prices and these are shown in the pricing tables within this price guide. The prices shown are manufacturer's recommended retail prices (RRP) unless otherwise stated, exclusive of VAT (currently at a rate of 20% which may be payable). These prices include the recommended cost of number plates, delivery to a Vauxhall Retailer of £583.33 (£700.00 including VAT), 12 months' Government Vehicle Excise Duty* and the DVLA new vehicle first registration fee of £55.00*.

Please note: The RRP does not include fuel supplied by the Retailer, motor insurance or any other goods or services supplied by agreement between the Retailer and customer.

Price protection for all Vauxhalls

Order a new Vauxhall for build in the current model year (as confirmed by your Retailer) for delivery no more than three months in advance and the price you are quoted is the price you pay. This is irrespective of any subsequent price rises between placing your order and delivery of your new commercial vehicle, but you must take delivery as soon as the commercial vehicle is available. Vauxhall Motors Limited is not liable for price adjustments caused by Government changes in the rate of VAT (currently 20%), Vehicle Excise Duty, DVLA new vehicle first registration fee or by any other applicable legislation or regulations.

In the event of an accident...

Vauxhall Accident Management helps keep you mobile following an accident. Benefits include vehicle recovery, Vauxhall-approved repairs and contacting your insurer. For more details, visit www.vauxhall.co.uk/AccidentManagement

Vehicle Excise Duty

The amount of Vehicle Excise Duty (road fund licence) payable on new commercial vehicles varies depending on gross vehicle weight (GVW) and European standard emissions compliance, as shown below*.

Up to 3500kg GVW	£265.00
Over 3500kg GVW	£165.00

*Correct at time of publication.

Customer Care Commitment

For added peace of mind, Vauxhall has an innovative Customer Care Commitment** that offers the following:

- Three-year vehicle warranty consisting of a one-year/unlimited mileage manufacturer's warranty and a second and third year manufacturer's warranty with a 60,000 miles (Combo) and 100,000 miles (Vivaro and Movano) limitation
- Vauxhall Assistance for 12 months from first registration
- Five years' body panel anti-perforation warranty

**Warranty is only on vehicles sourced from Vauxhall Motors Limited. Terms and conditions apply – please see your Vauxhall Retailer for details.

Vauxhall Assistance

Vauxhall Assistance is provided Automatically with every new Vauxhall Commercial Vehicle for 12 months from first registration and covers everything from accidents, mechanical breakdown to flat tyres. With Vauxhall Assistance help is literally just a free[†] phone call away, 24 hours a day, 365 days a year!

[†]Mobile phone users will be charged at their standard tariff.

Vauxhall Extended Warranty

For complete peace of mind Vauxhall offers an extended warranty that can be purchased on an annual basis following the expiry of the original new vehicle warranty. It covers most mechanical

and electrical components. Terms and conditions apply, for further details please contact your local Vauxhall Retailer.

Protecting the environment

Our products are increasingly winning environmental awards, both through the use of more recycled materials and by becoming cleaner and more efficient. For information on Vauxhall's efforts to achieve an environmentally sustainable future, including information on Design for Recycling, take-back of End-of-Life Vehicles (ELVs), and the recycling of ELVs, see www.vauxhall.co.uk/recycling

Van Business Centres

Keeping your van on the road. We know how important your van is to you, that's why we're geared up to minimise your downtime.

Our nationwide Van Business Centres provide fast, convenient value for money servicing, repairs and MOTs.

- All work is carried out by Vauxhall trained technicians using only genuine parts
- No appointments are required for diagnosis and we offer a 'while you wait' service

We have all the expertise required and will spare no effort to get you back in business as soon as possible.

Vauxhall Service Plan

Vauxhall Retailers offer a great service for owners of all Vauxhall vehicles. Value for money, regular offers and free check-ups, combined with the peace of mind that comes from using Vauxhall-trained technicians and genuine parts, help keep your vehicle in peak condition at all times. Every Vauxhall Retailer supports our customer promise:

We are Vauxhall experts

- Fully Vauxhall-trained technicians
- We use Vauxhall approved diagnostic equipment and specialist tools
- Full access to Vauxhall repair databases and technical centres

We are transparent

- Our invoicing will clearly set out the work at the price agreed with no hidden extras

We are never beaten on price

- We will match any written like for like service/repair quote from a local^{††} competitor using genuine repair methods and parts

We are convenient

- Flexible booking times to suit you
- 'One-stop shop' for every type of Vauxhall service
- While you wait facility on stocked tyres, batteries and exhausts
- Free courtesy vehicle or local collection with annual services and warranty work

We are thorough

- 25 point safety check with any workshop visit
- No obligation advice on essential and non-essential work
- Free check for safety enhancements and upgrades to your vehicle and software
- Free 'Wash and Vac' with every annual service
- Free fitting of wipers and external bulbs with annual services

^{††}A radius of five miles/20 minutes from your Vauxhall Retailer.

For more product information

For further information on the Vauxhall range or location of your nearest Vauxhall Retailer please call 0345 600 1500. Alternatively, details can be found on our website at www.vauxhall.co.uk

For more information call **0345 600 1500**

Discover the full Vauxhall range at **[vauxhall.co.uk](https://www.vauxhall.co.uk)**

Join us online

The invoice price, including delivery to Retailer, factory-fitted options, accessories fitted by the Retailer and number plates, is subject to VAT. Some feature descriptions in this guide may refer to, and some illustrations may show, optional equipment not included in the standard delivery. The information contained in this guide was accurate at the time of publication. We reserve the right to make changes in design and equipment. Please note that Vauxhall Retailers are not the agents of Vauxhall Motors Limited and are not authorised to bind Vauxhall Motors Limited by any specific or implied undertaking or representation. It is advisable to ensure that your motor insurance policy provides adequate cover for additional fitted options and accessories. The colours in this guide are only approximate actual colours. Illustrated optional equipment is available at extra charge. Availability, technical features and equipment provided on our vehicles can vary by model. For precise information on the equipment provided on our vehicles, please contact your local Vauxhall Retailer.

VAUXHALL

Price and Specification Guide
21 January 2021. Model Year 2021.5



Movano

CONTENTS

To find the information you want use the links below to navigate around the guide:

[Range Highlights](#)

[Prices and Weights](#)

[Fuel Economy and Emissions](#)

[Features and Options](#)

[Exterior Colours](#)

[Wheels and Tyres](#)

[Specifications](#)

[Dimensions](#)

[Accessories](#)

[Glossary of Terms](#)

[Further Information](#)

NEW MOVANO RANGE HIGHLIGHTS



EDITION PANEL VAN

Standard features include:

Infotainment:

- AM/FM/DAB digital radio • CD/MP3 Player
- Bluetooth® connectivity
- USB audio connection with iPod control
- Two 15-watt speakers
- RDS with Traffic Programme

Safety/security:

- Driver's airbag
- Height-adjustable outer front seatbelts
- Nearside blind spot/junction mirror (in front passenger sunvisor)
- Wide-angle mirror on driver's side
- Electronic stability programme with traction control
- Side wind assist
- Anti-lock braking system
- Full-height steel bulkhead
- Electronic engine deadlock immobiliser
- Remote control central door deadlocking with selective door locking
- Automatic lighting control with tunnel detection
- Internal lockable cargo doors
- Under-floor spare wheel storage – Wind down only when rear doors opened

Interior convenience/styling:

- Height-adjustable steering wheel
- Adjustable driver's seat with armrest
- Dual front passengers' bench seat
- 12-volt accessory socket
- Overhead storage shelf and 11L lidded glovebox
- Floor-mounted, load-securing eyes

Exterior convenience/styling:

- Rain-sensitive windscreen wipers
- Electrically operated front windows
- Foldable electrically adjustable/heated mirrors
- Easy access nearside sliding side-access door
- Unglazed rear doors

Mechanical:

- 80-litre fuel tank
- 26-litre AdBlue® tank
- 95Ah maintenance-free battery (105Ah on Tecshift models)
- 185A alternator



DOUBLECAB

Features over Panel Van:

- Fixed windows to standard nearside sliding side-access door and opposite body panel
- Dual front passengers' multi-function office bench seat, featuring flat-folding backrest with twin drinks holders, flat work surface, swivelling tray and underseat storage
- Four-individually contoured rear seats
- Inertia-reel lap and diagonal seatbelts
- Padded head restraints
- Full-length tray under rear seat cushion
- Full-height ABS plastic bulkhead with window



CHASSIS/CREW/ PLATFORM CAB MODELS

Chassis Cab, Crew Cab and Platform Cab models provide the perfect base for one of three factory-built conversions: Tipper, Dropside or Box Van. They also provide an excellent base for a wide variety of specialist body conversions.

Chassis/Crew Cab:

- Box section chassis rails
- Wide top sections with built-in mounting points
- Rear under-run bar (4500 models only)
- Crew Cab models additionally feature a four passenger rear bench seat with underseat storage

Platform Cab:

Ideal for those conversions requiring a low floor and walk-through access from the cab.

NEW MOVANO PANEL VAN PRICES/WEIGHTS

	Pack Code	Minimum Mass (kg)*	Maximum indicative payload (kg)*	Gross Vehicle Weights (GVW) (kg)	Plated weights (kg)		Towing weights (kg) Braked	Plated Gross Combination Weights (GCW) (kg)	Price (£) exc. VAT	On-the-road RRP (£) exc. VAT
					Front axle	Rear axle				
L1 H1 FWD EDITION PANEL VAN EURO 6D TEMP										
2800 2.3 (135PS) Turbo D	5D05 QJIB	1880	920	2800	1550	1650	2500	5300	28,695.00	29,598.33
3300 2.3 (135PS) Turbo D	5D05 QJIC	1880	1420	3300	1650	1900	2500	5800	29,945.00	30,848.33
3500 2.3 (135PS) Turbo D	5D05 QJID	1880	1620	3500	1850	2100	2500	6000	30,595.00	31,498.33
L1 H2 FWD EDITION PANEL VAN EURO 6D TEMP										
2800 2.3 (135PS) Turbo D	5D05 QJIE	1902	898	2800	1550	1650	2500	5300	29,295.00	30,198.33
3300 2.3 (135PS) Turbo D	5D05 QJIF	1902	1398	3300	1650	1900	2500	5800	30,545.00	31,448.33
3500 2.3 (135PS) Turbo D	5D05 QJIG	1902	1598	3500	1850	2100	2500	6000	31,195.00	32,098.33
3500 2.3 (150PS) Turbo D S/S	5D05 Q96G	1902	1598	3500	1850	2100	2500	6000	32,305.00	33,208.33
L1 H2 FWD EDITION PANEL VAN EURO V1d										
3500 2.3 (145PS) Turbo D S/S**	5D05 QXIG	1880	1620	3500	1850	2100	2500	6000	31,705.00	32,608.33
L2 H2 FWD EDITION PANEL VAN EURO 6D TEMP										
3300 2.3 (135PS) Turbo D	5D05 QJIH	1971	1329	3300	1700	1900	2500	5800	31,900.00	32,803.33
3500 2.3 (135PS) Turbo D	5D05 QJIJ	1971	1529	3500	1850	2100	2500	6000	32,550.00	33,453.33
3500 2.3 (135PS) Turbo D**	5D05 QMIJ	1971	1529	3500	1850	2100	2500	6000	32,550.00	33,453.33
3500 2.3 (150PS) Turbo D S/S	5D05 Q96J	1971	1529	3500	1850	2100	2500	6000	33,660.00	34,563.33
3500 2.3 (180PS) Turbo D S/S Tecshift	5D05 QBFJ	1974	1526	3500	1850	2100	2500	6000	35,785.00	36,688.33

S/S = Start/Stop.

Please note: On-the-road recommended retail prices (RRP) include number plates and delivery to Retailer of £583.33, 12 months' Vehicle Excise Duty (£265.00) and new vehicle first registration fee of £55.00. Excludes fuel and insurance.

All Movanos include BlueInjection. Vehicles with BlueInjection technology will need regular AdBlue® top-ups also between servicing requirements. An indicator integrated into the on-board computer will warn you when you need to top up. More information under www.vauxhall.co.uk/adblue. In accordance with regulations R (EC) No. 715/2007 and R (EC) No. 692/2008 (in the versions respectively applicable).

Gross plated weights (including axle weights) quoted on the vehicle plate are to UK plated weight specification and must never be exceeded. Unbraked towing weight 750kg – all models.

*For definitions please refer to Glossary of Terms. **Special build only (refer to Glossary of Terms), contact your Retailer for details.

NEW MOVANO PANEL VAN PRICES/WEIGHTS

	Pack Code	Minimum Mass (kg)*	Maximum indicative payload (kg)*	Gross Vehicle Weights (GVW) (kg)	Plated weights (kg)		Towing weights (kg) Braked	Plated Gross Combination Weights (GCW) (kg)	Price (£) exc. VAT	On-the-road RRP (£) exc. VAT
					Front axle	Rear axle				
L2 H3 FWD EDITION PANEL VAN EURO 6D TEMP										
3500 2.3 (135PS) Turbo D	5D05 QJIK	2000	1500	3500	1850	2100	2500	6000	33,250.00	34,153.33
3500 2.3 (150PS) Turbo D S/S	5D05 Q96K	2000	1500	3500	1850	2100	2500	6000	34,360.00	35,263.33
L3 H2 FWD EDITION PANEL VAN EURO 6D TEMP										
3500 2.3 (135PS) Turbo D	5D05 QJIL	2069	1431	3500	1850	2100	2500	6000	33,250.00	34,153.33
3500 2.3 (135PS) Turbo D**	5D05 QMIL	2069	1431	3500	1850	2100	2500	6000	33,250.00	34,153.33
3500 2.3 (150PS) Turbo D S/S	5D05 Q96L	2069	1431	3500	1850	2100	2500	6000	34,360.00	35,263.33
L3 H3 FWD EDITION PANEL VAN EURO 6D TEMP										
3500 2.3 (135PS) Turbo D	5D05 QJIQ	2076	1424	3500	1850	2100	2500	6000	33,950.00	34,853.33
3500 2.3 (150PS) Turbo D S/S	5D05 Q96Q	2076	1424	3500	1850	2100	2500	6000	35,060.00	35,963.33
L3 H2 RWD EDITION PANEL VAN EURO Vid										
3500 2.3 (130PS) Turbo D	5D05 QWIM	2297	1203	3500	1850	2300	2500	6000	34,550.00	35,453.33
3500 DRW 2.3 (130PS) Turbo D	5D05 QWIN	2352	1148	3500	1850	2800	3000	6500	35,150.00	36,053.33
4500 DRW 2.3 (130PS) Turbo D Tacho	5D05 QWIP	2352	2148	4500	1850	3200	3000	7500	36,805.00	37,608.33
L3 H3 RWD EDITION PANEL VAN EURO Vid										
3500 2.3 (130PS) Turbo D	5D05 QWIR	2315	1185	3500	1850	2300	2500	6000	35,250.00	36,153.33
3500 DRW 2.3 (130PS) Turbo D	5D05 QWIS	2375	1125	3500	1850	2800	3000	6500	35,850.00	36,753.33

S/S = Start/Stop. DRW = Dual Rear Wheels.

Please note: On-the-road recommended retail prices (RRP) include number plates and delivery to Retailer of £583.33, 12 months' Vehicle Excise Duty (£265.00) and new vehicle first registration fee of £55.00. Excludes fuel and insurance.

All Movanos include BlueInjection. Vehicles with BlueInjection technology will need regular AdBlue® top-ups also between servicing requirements. An indicator integrated into the on-board computer will warn you when you need to top up. More information under www.vauxhall.co.uk/adblue. In accordance with regulations R (EC) No. 715/2007 and R (EC) No. 692/2008 (in the versions respectively applicable).

Gross plated weights (including axle weights) quoted on the vehicle plate are to UK plated weight specification and must never be exceeded. Unbraked towing weight 750kg – all models.

*For definitions please refer to Glossary of Terms. **Special build only (refer to Glossary of Terms), contact your Retailer for details.

NEW MOVANO PANEL VAN PRICES/WEIGHTS

	Pack Code	Minimum Mass (kg)*	Maximum indicative payload (kg)*	Gross Vehicle Weights (GVW) (kg)	Plated weights (kg)		Towing weights (kg) Braked	Plated Gross Combination Weights (GCW) (kg)	Price (£) exc. VAT	On-the-road RRP (£) exc. VAT
					Front axle	Rear axle				
L4 H2 RWD EDITION PANEL VAN EURO VI d										
3500 2.3 (130PS) Turbo D	5D05 QWIY	2296	1204	3500	1850	2300	2500	6000	35,450.00	36,353.33
3500 DRW 2.3 (130PS) Turbo D	5D05 QWIU	2392	1108	3500	1850	2800	3000	6500	36,050.00	36,953.33
4500 DRW 2.3 (165PS) Turbo D S/S Tacho	5D05 QYIV	2392	2108	4500	1850	3200	3000	7500	40,065.00	40,868.33
L4 H3 RWD EDITION PANEL VAN EURO VI d										
3500 2.3 (130PS) Turbo D	5D05 QWIZ	2343	1157	3500	1850	2300	2500	6000	36,150.00	37,053.33
3500 2.3 (145PS) Turbo D S/S	5D05 QXIZ	2343	1157	3500	1850	2300	2500	6000	37,260.00	38,163.33
3500 DRW 2.3 (130PS) Turbo D	5D05 QWIW	2463	1037	3500	1850	2800	3000	6500	36,750.00	37,653.33
4500 DRW 2.3 (165PS) Turbo D S/S Tacho	5D05 QYIX	2463	2037	4500	1850	3200	3000	7500	40,765.00	41,568.33

S/S = Start/Stop. DRW = Dual Rear Wheels.

Please note: On-the-road recommended retail prices (RRP) include number plates and delivery to Retailer of £583.33, 12 months' Vehicle Excise Duty at £265.00 (£165.00 on 4500kg models) and new vehicle first registration fee of £55.00. Excludes fuel and insurance.

All Movanos include BlueInjection. Vehicles with BlueInjection technology will need regular AdBlue® top-ups also between servicing requirements. An indicator integrated into the on-board computer will warn you when you need to top up. More information under www.vauxhall.co.uk/adblue. In accordance with regulations R (EC) No. 715/2007 and R (EC) No. 692/2008 (in the versions respectively applicable).

Gross plated weights (including axle weights) quoted on the vehicle plate are to UK plated weight specification and must never be exceeded. Unbraked towing weight 750kg – all models.

*For definitions please refer to Glossary of Terms.

NEW MOVANO DOUBLECAB PRICES/WEIGHTS

	Pack Code	Minimum Mass (kg)*	Maximum indicative payload (kg)*	Gross Vehicle Weights (GVW) (kg)	Plated weights (kg)		Towing weights (kg) Braked	Plated Gross Combination Weights (GCW) (kg)	Price (£) exc. VAT	On-the-road RRP (£) exc. VAT
					Front axle	Rear axle				
L2 H2 FWD EDITION DOUBLECAB EURO 6D TEMP										
3500 2.3 (135PS) Turbo D	5DC5 QJIJ	2167	1333	3500	1850	2100	2500	6000	34,200.00	35,103.33
L3 H2 FWD EDITION DOUBLECAB EURO 6D TEMP										
3500 2.3 (135PS) Turbo D	5DC5 QJIL	2262	1238	3500	1850	2100	2500	6000	34,900.00	35,803.33

Please note: On-the-road recommended retail prices (RRP) include number plates and delivery to Retailer of £583.33, 12 months' Vehicle Excise Duty (£265.00) and new vehicle first registration fee of £55.00. Excludes fuel and insurance.

All Movanos include BlueInjection. Vehicles with BlueInjection technology will need regular AdBlue® top-ups also between servicing requirements. An indicator integrated into the on-board computer will warn you when you need to top up. More information under www.vauxhall.co.uk/adblue. In accordance with regulations R (EC) No. 715/2007 and R (EC) No. 692/2008 (in the versions respectively applicable).

Gross plated weights (including axle weights) quoted on the vehicle plate are to UK plated weight specification and must never be exceeded. Unbraked towing weight 750kg – all models.

*For definitions please refer to Glossary of Terms.

NEW MOVANO CHASSIS CAB PRICES/WEIGHTS

	Pack Code	Minimum Mass (kg)*	Maximum indicative payload (kg)*	Gross Vehicle Weights (GVW) (kg)	Plated weights (kg)		Towing weights (kg) Braked	Plated Gross Combination Weights (GCW) (kg)	Price (£) exc. VAT	On-the-road RRP (£) exc. VAT
					Front axle	Rear axle				
L2 H1 FWD CHASSIS CAB EURO 6D TEMP										
3500 2.3 (135PS) Turbo D	5D03 QMIE	1765	1735	3500	1850	2100	2500	6000	30,850.00	31,753.33
L3 H1 FWD CHASSIS CAB EURO 6D TEMP										
3500 2.3 (135PS) Turbo D	5D03 QMIL	1786	1714	3500	1850	2100	2500	6000	31,350.00	32,253.33
3500 2.3 (150PS) Turbo D S/S	5D03 QZIL	1786	1714	3500	1850	2100	2500	6000	32,460.00	33,363.33
L2 H1 RWD CHASSIS CAB EURO 6D TEMP										
3500 2.3 (130PS) Turbo D	5D03 QWIF	1878	1622	3500	1850	2300	2500	6000	32,150.00	33,053.33
3500 DRW 2.3 (130PS) Turbo D	5D03 QWIG	2058	1442	3500	1850	2800	3500	7000	32,765.00	33,668.33
4500 DRW 2.3 (165PS) Turbo D S/S Tacho	5D03 QYIH	2058	2442	4500	1850	3200	3000	7500	36,780.00	37,583.33
L3 H1 RWD CHASSIS CAB EURO V1d										
3500 2.3 (130PS) Turbo D	5D03 QWIM	1928	1572	3500	1850	2300	2500	6000	32,650.00	33,553.33
3500 2.3 (145PS) Turbo D S/S	5D03 QXIM	1928	1572	3500	1850	2300	2500	6000	33,760.00	34,663.33
3500 DRW 2.3 (130PS) Turbo D	5D03 QWIN	2069	1431	3500	1850	2800	3500	7000	33,250.00	34,153.33
4500 DRW 2.3 (165PS) Turbo D S/S Tacho	5D03 QYIP	2069	2431	4500	1850	3200	3000	7500	37,265.00	38,068.33

S/S = Start/Stop. DRW = Dual Rear Wheels.

Please note: On-the-road recommended retail prices (RRP) include number plates and delivery to Retailer of £583.33 (exc. VAT), 12 months' Vehicle Excise Duty at £265.00 (£165.00 on 4500kg models) and new vehicle first registration fee of £55.00. Excludes fuel and insurance.

All Movanos include BlueInjection. Vehicles with BlueInjection technology will need regular AdBlue® top-ups also between servicing requirements. An indicator integrated into the on-board computer will warn you when you need to top up.

More information under www.vauxhall.co.uk/adblue. In accordance with regulations R (EC) No. 715/2007 and R (EC) No. 692/2008 (in the versions respectively applicable).

All conversions must follow 'Vauxhall Converter Requirements' including recommended dimensional data, detailed within Part 1, available at: www.converters-and-groupe-psa.com. The weight of any fitted conversion body will have to be deducted from these figures to establish actual payload and is subject to correct weight distribution. Variations from the recommended dimensions or weights may affect the vehicle's overall centre of gravity and stability. From 29 April 2013 conversion of N1 vehicles was affected by changes to type approval - for further information refer to the VCA website (N2 vehicles were affected from 29 October 2014). For further information please contact conversions@vauxhall.co.uk

Gross plated weights (including axle weights) quoted on the vehicle plate are to UK plated weight specification and must never be exceeded. Unbraked towing weight 750kg - all models.

*For definitions please refer to Glossary of Terms.

NEW MOVANO CHASSIS CAB PRICES/WEIGHTS

	Pack Code	Minimum Mass (kg)*	Maximum indicative payload (kg)*	Gross Vehicle Weights (GVW) (kg)	Plated weights (kg)			Plated Gross Combination Weights (GCW) (kg)	Price (£) exc. VAT	On-the-road RRP (£) exc. VAT
					Front axle	Rear axle	Towing weights (kg) Braked			
L4 H1 RWD CHASSIS CAB EURO VI d										
3500 DRW 2.3 (130PS) Turbo D	5D03 QWIU	2074	1426	3500	1850	2800	3500	7000	33,950.00	34,853.33
3500 DRW 2.3 (145PS) Turbo D S/S	5D03 QXIU	2074	1426	3500	1850	2800	3500	7000	35,060.00	35,963.33
4500 DRW 2.3 (165PS) Turbo D S/S Tacho	5D03 QYIV	2074	2426	4500	1850	3200	3000	7500	37,965.00	38,768.33

S/S = Start/Stop. DRW = Dual Rear Wheels.

Please note: On-the-road recommended retail prices (RRP) include number plates and delivery to Retailer of £583.33 (exc. VAT), 12 months' Vehicle Excise Duty at £265.00 (£165.00 on 4500kg models) and new vehicle first registration fee of £55.00. Excludes fuel and insurance.

All Movanos include BlueInjection. Vehicles with BlueInjection technology will need regular AdBlue® top-ups also between servicing requirements. An indicator integrated into the on-board computer will warn you when you need to top up.

More information under www.vauxhall.co.uk/adblue. In accordance with regulations R (EC) No. 715/2007 and R (EC) No. 692/2008 (in the versions respectively applicable).

All conversions must follow 'Vauxhall Converter Requirements' including recommended dimensional data, detailed within Part 1, available at: www.converters-and-groupe-psa.com. The weight of any fitted conversion body will have to be deducted from these figures to establish actual payload and is subject to correct weight distribution. Variations from the recommended dimensions or weights may affect the vehicle's overall centre of gravity and stability. From 29 April 2013 conversion of N1 vehicles was affected by changes to type approval – for further information refer to the VCA website (N2 vehicles were affected from 29 October 2014). For further information please contact conversions@vauxhall.co.uk

Gross plated weights (including axle weights) quoted on the vehicle plate are to UK plated weight specification and must never be exceeded. Unbraked towing weight 750kg – all models.

*For definitions please refer to Glossary of Terms.

NEW MOVANO CREW CAB PRICES/WEIGHTS

	Pack Code	Minimum Mass (kg)*	Maximum indicative payload (kg)*	Gross Vehicle Weights (GVW) (kg)	Plated weights (kg)			Plated Gross Combination Weights (GCW) (kg)	Price (£) exc. VAT	On-the-road RRP (£) exc. VAT
					Front axle	Rear axle	Towing weights (kg) Braked			
L2 H1 FWD CREW CAB EURO 6D TEMP										
3500 2.3 (135PS) Turbo D	5D43 QMIE	1949	1551	3500	1850	2100	2500	6000	31,750.00	32,653.33
L3 H1 FWD CREW CAB EURO 6D TEMP										
3500 2.3 (135PS) Turbo D	5D43 QMIL	1958	1542	3500	1850	2100	2500	6000	32,250.00	33,153.33
L3 H1 RWD CREW CAB EURO Vid										
3500 2.3 (130PS) Turbo D	5D43 QWIM	2099	1401	3500	1850	2300	2500	6000	33,550.00	34,453.33
3500 DRW 2.3 (130PS) Turbo D	5D43 QWIN	2224	1276	3500	1850	2800	3500	7000	34,150.00	35,053.33
L4 H1 RWD CREW CAB EURO Vid										
3500 2.3 (130PS) Turbo D	5D43 QWIU	2273	1227	3500	1850	2800	3500	7000	34,850.00	35,753.33

DRW = Dual Rear Wheels.

Please note: On-the-road recommended retail prices (RRP) include number plates and delivery to Retailer of £583.33 (exc. VAT), 12 months' Vehicle Excise Duty at £265.00 (£165.00 on 4500kg models) and new vehicle first registration fee of £55.00. Excludes fuel and insurance.

All Movanos include BlueInjection. Vehicles with BlueInjection technology will need regular AdBlue® top-ups also between servicing requirements. An indicator integrated into the on-board computer will warn you when you need to top up.

More information under www.vauxhall.co.uk/adblue. In accordance with regulations R (EC) No. 715/2007 and R (EC) No. 692/2008 (in the versions respectively applicable).

All conversions must follow 'Vauxhall Convertor Requirements' including recommended dimensional data, detailed within Part 1, available at: www.converters-and-groupe-psa.com. The weight of any fitted conversion body will have to be deducted from these figures to establish actual payload and is subject to correct weight distribution. Variations from the recommended dimensions or weights may affect the vehicle's overall centre of gravity and stability. From 29 April 2013 conversion of N1 vehicles was affected by changes to type approval - for further information refer to the VCA website (N2 vehicles were affected from 29 October 2014). For further information please contact conversions@vauxhall.co.uk

Gross plated weights (including axle weights) quoted on the vehicle plate are to UK plated weight specification and must never be exceeded. Unbraked towing weight 750kg - all models.

*For definitions please refer to Glossary of Terms.

NEW MOVANO PLATFORM CAB PRICES/WEIGHTS

	Pack Code	Minimum Mass (kg)*	Maximum indicative payload (kg)*	Gross Vehicle Weights (GVW) (kg)	Plated weights (kg)		Towing weights (kg) Braked	Plated Gross Combination Weights (GCW) (kg)	Price (£) exc. VAT	On-the-road RRP (£) exc. VAT
					Front axle	Rear axle				
L3 H1 FWD PLATFORM CAB EURO 6D TEMP										
3500 2.3 (135PS) Turbo D	5D32 QMIL	1679	1821	3500	1850	2100	2500	6000	31,350.00	32,253.33
3500 2.3 (150PS) Turbo D S/S	5D32 QZIL	1679	1821	3500	1850	2100	2500	6000	32,460.00	33,363.33
L3 H2 FWD PLATFORM CAB EURO 6D TEMP										
3500 2.3 (150PS) Turbo D S/S	5D32 QZIP	1698	1802	3500	1850	2100	2500	6000	33,060.00	33,963.33

S/S = Start/Stop.

Please note: On-the-road recommended retail prices (RRP) include number plates and delivery to Retailer of £583.33 (exc. VAT), 12 months' Vehicle Excise Duty at £265.00 and new vehicle first registration fee of £55.00. Excludes fuel and insurance.

All Movanos include BlueInjection. Vehicles with BlueInjection technology will need regular AdBlue® top-ups also between servicing requirements. An indicator integrated into the on-board computer will warn you when you need to top up.

More information under www.vauxhall.co.uk/adblue. In accordance with regulations R (EC) No. 715/2007 and R (EC) No. 692/2008 (in the versions respectively applicable).

All conversions must follow 'Vauxhall Convertor Requirements' including recommended dimensional data, detailed within Part 1, available at: www.converters-and-groupe-psa.com. The weight of any fitted conversion body will have to be deducted from these figures to establish actual payload and is subject to correct weight distribution. Variations from the recommended dimensions or weights may affect the vehicle's overall centre of gravity and stability. From 29 April 2013 conversion of N1 vehicles was affected by changes to type approval – for further information refer to the VCA website (N2 vehicles were affected from 29 October 2014). For further information please contact conversions@vauxhall.co.uk

Gross plated weights (including axle weights) quoted on the vehicle plate are to UK plated weight specification and must never be exceeded. Unbraked towing weight 750kg – all models.

*For definitions please refer to Glossary of Terms.

NEW MOVANO TIPPER PRICES/WEIGHTS

	Pack Code	Minimum Mass (kg)*	Maximum indicative payload (kg)*	Gross Vehicle Weights (GVW) (kg)	Plated weights (kg)		Towing weights (kg) Braked	Plated Gross Combination Weights (GCW) (kg)	Price (£) exc. VAT	On-the-road RRP (£) exc. VAT
					Front axle	Rear axle				
L2 H1 FWD CHASSIS CAB TIPPER EURO 6D TEMP										
3500 2.3 (135PS) Turbo D	5DT1 QMIE	2262	1238	3500	1850	2100	2500	6000	37,750.00	38,653.33
L2 H1 RWD CHASSIS CAB TIPPER EURO Vid										
3500 DRW 2.3 (130PS) Turbo D	5DT1 QWIG	2544	956	3500	1850	2800	3500	7000	39,665.00	40,568.33
3500 DRW 2.3 (145PS) Turbo D S/S	5DT1 QXIG	2544	956	3500	1850	2800	3500	7000	40,775.00	41,678.33
L3 H1 RWD CHASSIS CAB TIPPER EURO Vid										
3500 DRW 2.3 (130PS) Turbo D	5DT1 QWIN	2658	842	3500	1850	2800	3500	7000	40,150.00	41,053.33
L3 H1 FWD CREW CAB TIPPER EURO 6D TEMP (6-seater)										
3500 2.3 (145PS) Turbo D S/S	5DTC QXIL	2446	1054	3500	1850	2100	2500	6000	40,260.00	41,163.33

S/S = Start/Stop. DRW = Dual Rear Wheels.

Please note: On-the-road recommended retail prices (RRP) include number plates and delivery to Retailer of £583.33 (exc. VAT), 12 months' Vehicle Excise Duty at £265.00 (£165.00 on 4500kg models) and new vehicle first registration fee of £55.00. Excludes fuel and insurance.

All Movanos include BlueInjection. Vehicles with BlueInjection technology will need regular AdBlue® top-ups also between servicing requirements. An indicator integrated into the on-board computer will warn you when you need to top up. More information under www.vauxhall.co.uk/adblue. In accordance with regulations R (EC) No. 715/2007 and R (EC) No. 692/2008 (in the versions respectively applicable).

Gross plated weights (including axle weights) quoted on the vehicle plate are to UK plated weight specification and must never be exceeded. Unbraked towing weight 750kg – all models.

*For definitions please refer to Glossary of Terms.

NEW MOVANO DROPSIDE PRICES/WEIGHTS

	Pack Code	Minimum Mass (kg)*	Maximum indicative payload (kg)*	Gross Vehicle Weights (GVW) (kg)	Plated weights (kg)		Towing weights (kg) Braked	Plated Gross Combination Weights (GCW) (kg)	Price (£) exc. VAT	On-the-road RRP (£) exc. VAT
					Front axle	Rear axle				
L2 H1 FWD CHASSIS CAB DROPSIDE EURO 6D TEMP										
3500 2.3 (135PS) Turbo D	5DD1 QMIE	2077	1423	3500	1850	2100	2500	6000	32,800.00	33,703.33
L3 H1 FWD CHASSIS CAB DROPSIDE EURO 6D TEMP										
3500 2.3 (135PS) Turbo D	5DD1 QMIL	2151	1349	3500	1850	2100	2500	6000	33,800.00	34,703.33
L2 H1 RWD CHASSIS CAB DROPSIDE EURO Vid										
3500 2.3 (130PS) Turbo D	5DD1 QWIF	2288	1212	3500	1850	2300	2500	6000	34,100.00	35,003.33
3500 DRW 2.3 (130PS) Turbo D	5DD1 QWIG	2391	1109	3500	1850	2800	3500	7000	34,715.00	35,618.33
L3 H1 RWD CHASSIS CAB DROPSIDE EURO Vid										
3500 DRW 2.3 (145PS) Turbo D S/S	5DD1 QXIN	2442	1058	3500	1850	2800	3500	7000	36,810.00	37,713.33
L4 H1 RWD CHASSIS CAB DROPSIDE EURO Vid										
3500 DRW 2.3 (145PS) Turbo D S/S	5DD1 QXIU	2483	1017	3500	1850	2800	3500	7000	37,510.00	38,413.33
L3 H1 FWD CREW CAB DROPSIDE EURO 6D TEMP										
3500 2.3 (135PS) Turbo D	5DDC QMIL	2271	1229	3500	1850	2100	2500	6000	34,200.00	35,103.33
L4 H1 RWD CREW CAB DROPSIDE EURO Vid										
3500 2.3 (130PS) Turbo D	5DDC QWIV	2627	1873	4500	1850	3200	3000	7500	37,300.00	38,203.33

S/S = Start/Stop. DRW = Dual Rear Wheels.

Please note: On-the-road recommended retail prices (RRP) include number plates and delivery to Retailer of £583.33 (exc. VAT), 12 months' Vehicle Excise Duty at £265.00 (£165.00 on 4500kg models) and new vehicle first registration fee of £55.00. Excludes fuel and insurance.

All Movanos include BlueInjection. Vehicles with BlueInjection technology will need regular AdBlue® top-ups also between servicing requirements. An indicator integrated into the on-board computer will warn you when you need to top up. More information under www.vauxhall.co.uk/adblue. In accordance with regulations R (EC) No. 715/2007 and R (EC) No. 692/2008 (in the versions respectively applicable).

*For definitions please refer to Glossary of Terms.

NEW MOVANO BOX VAN PRICES/WEIGHTS

	Pack Code	Minimum Mass (kg)*	Maximum indicative payload (kg)*	Gross Vehicle Weights (GVW) (kg)	Plated weights (kg)		Towing weights (kg) Braked	Plated Gross Combination Weights (GCW) (kg)	Price (£) exc. VAT	On-the-road RRP (£) exc. VAT
					Front axle	Rear axle				
L3 H1 FWD CHASSIS CAB BOX VAN 20 cu.m EURO VI d										
3500 2.3 (145PS) Turbo D S/S	5DB1 QXIL	2367	1133	3500	1850	2100	2500	6000	38,140.00	39,043.33

S/S = Start/Stop.

Please note: On-the-road recommended retail prices (RRP) include number plates and delivery to Retailer of £583.33 (exc. VAT), 12 months' Vehicle Excise Duty £265.00 and new vehicle first registration fee of £55.00. Excludes fuel and insurance.

All Movanos include BlueInjection. Vehicles with BlueInjection technology will need regular AdBlue® top-ups also between servicing requirements. An indicator integrated into the on-board computer will warn you when you need to top up. More information under www.vauxhall.co.uk/adblue. In accordance with regulations R (EC) No. 715/2007 and R (EC) No. 692/2008 (in the versions respectively applicable).

*For definitions please refer to Glossary of Terms.

NEW MOVANO FUEL ECONOMY/EMISSIONS

	NEDC mpg (litres/100km) [#]		WLTP Fuel economy mpg (litres/100km) ^{##}			CO ₂ (g/km) ^{##}	
	Combined	CO ₂ (g/km) [#]	Combined Low	Combined High	High	Low	
L1 H1 FWD EDITION PANEL VAN EURO 6D TEMP							
2800 2.3 (135PS) Turbo D	41.6 (6.8)	181	24.9 (9.6)	31.0 (9.1)	251	240	
3300 2.3 (135PS) Turbo D	41.6 (6.8)	180	28.8 (9.8)	30.4 (9.3)	257	244	
3500 2.3 (135PS) Turbo D	41.6 (6.8)	180	28.8 (9.8)	30.1 (9.4)	259	247	
3500 2.3 (150PS) Turbo D S/S	47.0 (6.0)	158	27.4 (10.3)	30.7 (9.2)	270	241	
L1 H2 FWD EDITION PANEL VAN EURO 6D TEMP							
2800 2.3 (135PS) Turbo D	39.2 (7.2)	191	28.8 (9.8)	30.1 (9.4)	258	246	
3300 2.3 (135PS) Turbo D	39.2 (7.2)	190	28.2 (10.0)	29.7 (9.5)	263	251	
3500 2.3 (135PS) Turbo D	39.2 (7.2)	190	28.0 (10.1)	29.4 (9.6)	265	253	
3500 2.3 (150PS) Turbo D S/S	46.3 (6.1)	161	27.4 (10.3)	30.1 (9.4)	270	247	
L2 H2 FWD EDITION PANEL VAN EURO 6D TEMP							
3300 2.3 (135PS) Turbo D	39.2 (7.2)	191	28.0 (10.1)	29.4 (9.6)	265	252	
3500 2.3 (135PS) Turbo D	39.2 (7.2)	191	27.7 (10.2)	29.1 (9.7)	267	254	
3500 2.3 (150PS) Turbo D S/S	46.3 (6.1)	162	27.4 (10.3)	30.1 (9.4)	270	248	
3500 2.3 (180PS) Turbo D S/S Tecshift	38.2 (7.4)	194	28.0 (10.1)	29.4 (9.6)	264	251	
L2 H3 FWD EDITION PANEL VAN EURO 6D TEMP							
3500 2.3 (135PS) Turbo D	37.7 (7.5)	198	27.2 (10.4)	28.5 (9.9)	273	261	
3500 2.3 (150PS) Turbo D S/S	45.6 (6.2)	164	27.4 (10.3)	29.1 (9.7)	270	254	
3500 2.3 (180PS) Turbo D S/S Tecshift	37.6 (7.5)	198	26.9 (10.5)	28.5 (9.9)	275	259	

S/S = Start/Stop.

For fuel economy and CO₂ two sets of data are provided. All engines are validated to emissions standard Euro 6D Temp (6.2) which uses the newer WLTP cycle. This cycle is intended to be a closer representation to economy achieved in the real world and is included for this transparency. NEDC figures are not from the older cycle but in fact are a derived back-correlation calculation from the WLTP test data. Some systems and protocols such as the 2020 CO₂ target will use this figure, and hence it is included for this, and also to enable comparison to outgoing models.

[#]Fuel consumption data and CO₂ emission data are determined using the Worldwide harmonized Light vehicles Test Procedure (WLTP), and the relevant values are translated back to allow the comparability into NEDC, according to regulations R (EC) No. 715/2007, R (EU) No. 2017/1153 and R (EU) No. 2017/1151. The values do not take into account in particular use and driving conditions, equipment or options and may vary depending on the format of tyres. For more information on official fuel consumption and CO₂ emission values, please read the guidelines at <http://vanfueldata.dft.gov.uk/>

^{##}Fuel consumption and CO₂ emission data are determined according to the WLTP test cycle. Full data relating to WLTP test cycles can be found at: www.vauxhall.co.uk/wltp

NEW MOVANO FUEL ECONOMY/EMISSIONS

	NEDC mpg (litres/100km) [#]		WLTP Fuel economy mpg (litres/100km) ^{##}			CO ₂ (g/km) ^{##}	
	Combined	CO ₂ (g/km) [#]	Combined Low	Combined High	High	Low	
L3 H2 FWD EDITION PANEL VAN EURO 6D TEMP							
3500 2.3 (135PS) Turbo D	38.2 (7.4)	196	27.4 (10.3)	28.8 (9.8)	270	256	
3500 2.3 (150PS) Turbo D S/S	45.6 (6.2)	163	27.4 (10.3)	29.7 (9.5)	270	250	
3500 2.3 (180PS) Turbo D S/S	40.3 (7.0)	185	26.9 (10.5)	29.1 (9.7)	277	256	
3500 2.3 (180PS) Turbo D S/S Tecshift	37.6 (7.5)	197	26.9 (10.5)	29.1 (9.7)	275	254	
L3 H3 FWD EDITION PANEL VAN EURO 6D TEMP							
3500 2.3 (135PS) Turbo D	36.7 (7.7)	203	27.2 (10.4)	28.2 (10.0)	274	263	
3500 2.3 (150PS) Turbo D S/S	44.8 (6.3)	165	27.4 (10.3)	29.1 (9.7)	270	256	
L3 H2 RWD EDITION PANEL VAN EURO Vid							
3500 2.3 (130PS) Turbo D	32.9 (8.6)	224	-	-	-	-	
3500 DRW 2.3 (130PS) Turbo D	32.9 (8.6)	224	-	-	-	-	
4500 DRW 2.3 (130PS) Turbo D	32.9 (8.6)	224	-	-	-	-	
L3 H3 RWD EDITION PANEL VAN EURO Vid							
3500 2.3 (130PS) Turbo D	32.9 (8.6)	224	-	-	-	-	
3500 DRW 2.3 (130PS) Turbo D	32.9 (8.6)	224	-	-	-	-	
L4 H2 RWD EDITION PANEL VAN EURO Vid							
3500 2.3 (130PS) Turbo D	32.9 (8.6)	224	-	-	-	-	
3500 DRW 2.3 (130PS) Turbo D	32.9 (8.6)	224	-	-	-	-	
4500 DRW 2.3 (165PS) Turbo D S/S	34.9 (8.1)	211	-	-	-	-	

S/S = Start/Stop. DRW = Dual Rear Wheels.

For fuel economy and CO₂ two sets of data are provided. All engines are validated to emissions standard Euro 6D Temp (6.2) which uses the newer WLTP cycle. This cycle is intended to be a closer representation to economy achieved in the real world and is included for this transparency. NEDC figures are not from the older cycle but in fact are a derived back-correlation calculation from the WLTP test data. Some systems and protocols such as the 2020 CO₂ target will use this figure, and hence it is included for this, and also to enable comparison to outgoing models.

[#]Fuel consumption data and CO₂ emission data are determined using the Worldwide harmonized Light vehicles Test Procedure (WLTP), and the relevant values are translated back to allow the comparability into NEDC, according to regulations R (EC) No. 715/2007, R (EU) No. 2017/1153 and R (EU) No. 2017/1151. The values do not take into account in particular use and driving conditions, equipment or options and may vary depending on the format of tyres. For more information on official fuel consumption and CO₂ emission values, please read the guidelines at <http://vanfueldata.dft.gov.uk/>

^{##}Fuel consumption and CO₂ emission data are determined according to the WLTP test cycle. Full data relating to WLTP test cycles can be found at: www.vauxhall.co.uk/wltp

NEW MOVANO FUEL ECONOMY/EMISSIONS

	NEDC mpg (litres/100km) [#]		WLTP Fuel economy mpg (litres/100km) ^{##}			CO ₂ (g/km) ^{##}	
	Combined	CO ₂ (g/km) [#]	Combined Low	Combined High	High	Low	
L4 H3 RWD EDITION PANEL VAN EURO VI^d							
3500 2.3 (130PS) Turbo D	32.9 (8.6)	224	-	-	-	-	
3500 2.3 (145PS) Turbo D S/S	38.7 (7.3)	191	-	-	-	-	
3500 DRW 2.3 (130PS) Turbo D	32.9 (8.6)	224	-	-	-	-	
4500 DRW 2.3 (165PS) Turbo D S/S	34.9 (8.1)	211	-	-	-	-	
L2 H2 FWD EDITION DOUBLECAB EURO 6D TEMP							
3500 2.3 (135PS) Turbo D	36.7 (7.7)	202	27.7 (10.2)	28.8 (9.8)	267	258	
L3 H2 FWD EDITION DOUBLECAB EURO 6D TEMP							
3500 2.3 (135PS) Turbo D	36.7 (7.7)	204	27.7 (10.2)	28.5 (9.9)	269	261	
L2 H1 FWD CHASSIS CAB EURO 6D TEMP							
3500 2.3 (135PS) Turbo D	39.2 (7.2)	191	22.8 (12.4)	22.8 (12.4)	327	327	
L3 H1 FWD CHASSIS CAB EURO 6D TEMP							
3500 2.3 (135PS) Turbo D	39.2 (7.2)	191	22.8 (12.4)	22.8 (12.4)	327	327	
3500 2.3 (150PS) Turbo D S/S	42.8 (6.6)	175	23.0 (12.3)	22.9 (12.3)	323	323	
L2 H1 RWD CHASSIS CAB EURO 6D TEMP							
3500 2.3 (130PS) Turbo D	39.2 (7.2)	224	-	-	-	-	
3500 DRW 2.3 (130PS) Turbo D	39.2 (7.2)	224	-	-	-	-	
4500 DRW 2.3 (165PS) Turbo D S/S	34.9 (8.1)	211	-	-	-	-	

S/S = Start/Stop. DRW = Dual Rear Wheels.

For fuel economy and CO₂ two sets of data are provided. All engines are validated to emissions standard Euro 6D Temp (6.2) which uses the newer WLTP cycle. This cycle is intended to be a closer representation to economy achieved in the real world and is included for this transparency. NEDC figures are not from the older cycle but in fact are a derived back-correlation calculation from the WLTP test data. Some systems and protocols such as the 2020 CO₂ target will use this figure, and hence it is included for this, and also to enable comparison to outgoing models.

[#]Fuel consumption data and CO₂ emission data are determined using the Worldwide harmonized Light vehicles Test Procedure (WLTP), and the relevant values are translated back to allow the comparability into NEDC, according to regulations R (EC) No. 715/2007, R (EU) No. 2017/1153 and R (EU) No. 2017/1151. The values do not take into account in particular use and driving conditions, equipment or options and may vary depending on the format of tyres. For more information on official fuel consumption and CO₂ emission values, please read the guidelines at <http://vanfueldata.dft.gov.uk/>

^{##}Fuel consumption and CO₂ emission data are determined according to the WLTP test cycle. Full data relating to WLTP test cycles can be found at: www.vauxhall.co.uk/wltp

NEW MOVANO FUEL ECONOMY/EMISSIONS

	NEDC mpg (litres/100km) [#]		WLTP Fuel economy mpg (litres/100km) ^{##}		CO ₂ (g/km) ^{##}	
	Combined	CO ₂ (g/km) [#]	Combined Low	Combined High	High	Low
L3 H1 RWD CHASSIS CAB EURO VI_d						
3500 2.3 (130PS) Turbo D	32.9 (8.6)	224	-	-	-	-
3500 2.3 (145PS) Turbo D S/S	38.7 (7.3)	191	-	-	-	-
3500 DRW 2.3 (130PS) Turbo D	32.9 (8.6)	224	-	-	-	-
4500 DRW 2.3 (165PS) Turbo D S/S	34.9 (8.1)	211	-	-	-	-
L4 H1 RWD CHASSIS CAB EURO VI_d						
3500 DRW 2.3 (130PS) Turbo D	32.9 (8.6)	224	-	-	-	-
3500 DRW 2.3 (145PS) Turbo D S/S	38.7 (7.3)	191	-	-	-	-
4500 DRW 2.3 (165PS) Turbo D S/S	34.9 (8.1)	211	-	-	-	-
L2 H1 FWD CREW CAB EURO 6D TEMP						
3500 2.3 (135PS) Turbo D	39.2 (7.2)	191	22.8 (12.4)	22.8 (12.4)	327	327
L3 H1 FWD CREW CAB EURO 6D TEMP						
3500 2.3 (135PS) Turbo D	39.2 (7.2)	191	22.8 (12.4)	22.8 (12.4)	327	327
L3 H1 RWD CREW CAB EURO VI_d						
3500 2.3 (130PS) Turbo D	39.2 (7.2)	224	-	-	-	-
3500 DRW 2.3 (130PS) Turbo D	39.2 (7.2)	224	-	-	-	-
L4 H1 RWD CREW CAB EURO VI_d						
3500 DRW 2.3 (130PS) Turbo D	39.2 (7.2)	224	-	-	-	-

S/S = Start/Stop. DRW = Dual Rear Wheels.

For fuel economy and CO₂ two sets of data are provided. All engines are validated to emissions standard Euro 6D Temp (6.2) which uses the newer WLTP cycle. This cycle is intended to be a closer representation to economy achieved in the real world and is included for this transparency. NEDC figures are not from the older cycle but in fact are a derived back-correlation calculation from the WLTP test data. Some systems and protocols such as the 2020 CO₂ target will use this figure, and hence it is included for this, and also to enable comparison to outgoing models.

[#]Fuel consumption data and CO₂ emission data are determined using the Worldwide harmonized Light vehicles Test Procedure (WLTP), and the relevant values are translated back to allow the comparability into NEDC, according to regulations R (EC) No. 715/2007, R (EU) No. 2017/1153 and R (EU) No. 2017/1151. The values do not take into account in particular use and driving conditions, equipment or options and may vary depending on the format of tyres. For more information on official fuel consumption and CO₂ emission values, please read the guidelines at <http://vanfueldata.dft.gov.uk/>

^{##}Fuel consumption and CO₂ emission data are determined according to the WLTP test cycle. Full data relating to WLTP test cycles can be found at: www.vauxhall.co.uk/wltp

NEW MOVANO FUEL ECONOMY/EMISSIONS

	NEDC mpg (litres/100km) [#]		WLTP Fuel economy mpg (litres/100km) ^{##}			CO ₂ (g/km) ^{##}	
	Combined	CO ₂ (g/km) [#]	Combined Low	Combined High	High	Low	
L3 H1 FWD PLATFORM CAB EURO 6D TEMP							
3500 2.3 (135PS) Turbo D	39.2 (7.2)	191	22.8 (12.4)	22.8 (12.4)	327	327	
3500 2.3 (150PS) Turbo D S/S	42.8 (6.6)	175	23.0 (12.3)	23.0 (12.3)	323	323	
L3 H2 FWD PLATFORM CAB EURO 6D TEMP							
3500 2.3 (150PS) Turbo D S/S	42.8 (6.6)	175	23.0 (12.3)	23.0 (12.3)	323	323	
L2 H1 FWD CHASSIS CAB TIPPER EURO 6D TEMP							
3500 2.3 (135PS) Turbo D	39.2 (7.2)	191	22.8 (12.4)	22.8 (12.4)	327	327	
L2 H1 RWD CHASSIS CAB TIPPER EURO Vid							
3500 DRW 2.3 (130PS) Turbo D	32.9 (8.6)	224	-	-	-	-	
3500 DRW 2.3 (145PS) Turbo D S/S	38.7 (7.3)	191	-	-	-	-	
L3 H1 RWD CHASSIS CAB TIPPER EURO Vid							
3500 DRW 2.3 (130PS) Turbo D	32.9 (8.6)	224	-	-	-	-	
L3 H1 FWD CREW CAB TIPPER EURO 6D TEMP (6-seater)							
3500 2.3 (150PS) Turbo D S/S	38.7 (7.3)	191	-	-	-	-	
L2 H1 FWD CHASSIS CAB DROPSIDE EURO 6D TEMP							
3500 2.3 (135PS) Turbo D	39.2 (7.2)	191	22.8 (12.4)	22.8 (12.4)	327	327	
L3 H1 FWD CHASSIS CAB DROPSIDE EURO 6D TEMP							
3500 2.3 (135PS) Turbo D	39.2 (7.2)	191	22.8 (12.4)	22.8 (12.4)	327	327	

S/S = Start/Stop. DRW = Dual Rear Wheels.

For fuel economy and CO₂ two sets of data are provided. All engines are validated to emissions standard Euro 6D Temp (6.2) which uses the newer WLTP cycle. This cycle is intended to be a closer representation to economy achieved in the real world and is included for this transparency. NEDC figures are not from the older cycle but in fact are a derived back-correlation calculation from the WLTP test data. Some systems and protocols such as the 2020 CO₂ target will use this figure, and hence it is included for this, and also to enable comparison to outgoing models.

[#]Fuel consumption data and CO₂ emission data are determined using the Worldwide harmonized Light vehicles Test Procedure (WLTP), and the relevant values are translated back to allow the comparability into NEDC, according to regulations R (EC) No. 715/2007, R (EU) No. 2017/1153 and R (EU) No. 2017/1151. The values do not take into account in particular use and driving conditions, equipment or options and may vary depending on the format of tyres. For more information on official fuel consumption and CO₂ emission values, please read the guidelines at <http://vanfueldata.dft.gov.uk/>

^{##}Fuel consumption and CO₂ emission data are determined according to the WLTP test cycle. Full data relating to WLTP test cycles can be found at: www.vauxhall.co.uk/wltp

NEW MOVANO FUEL ECONOMY/EMISSIONS

	NEDC mpg (litres/100km) [#]		WLTP Fuel economy mpg (litres/100km) ^{##}		CO ₂ (g/km) ^{##}	
	Combined	CO ₂ (g/km) [#]	Combined Low	Combined High	High	Low
L2 H1 RWD CHASSIS CAB DROPSIDE EURO VId						
3500 2.3 (130PS) Turbo D	32.9 (8.6)	224	-	-	-	-
3500 DRW 2.3 (130PS) Turbo D	32.9 (8.6)	224	-	-	-	-
L3 H1 RWD CHASSIS CAB DROPSIDE EURO VId						
3500 DRW 2.3 (145PS) Turbo D S/S	38.7 (7.3)	191	-	-	-	-
L4 H1 RWD CHASSIS CAB DROPSIDE EURO VId						
3500 DRW 2.3 (145PS) Turbo D S/S	38.7 (7.3)	191	-	-	-	-
L3 H1 FWD CREW CAB DROPSIDE EURO 6D TEMP						
3500 2.3 (135PS) Turbo D	39.2 (7.2)	191	22.8 (12.4)	22.8 (12.4)	327	327
L4 H1 RWD CREW CAB DROPSIDE EURO VId						
3500 2.3 (130PS) Turbo D	tba	tba	-	-	-	-
L3 H1 FWD CHASSIS CAB BOX VAN 20 cu.m EURO VId						
3500 DRW 2.3 (145PS) Turbo D	38.7 (7.3)	191	-	-	-	-

S/S = Start/Stop. DRW = Dual Rear Wheels.

For fuel economy and CO₂ two sets of data are provided. All engines are validated to emissions standard Euro 6D Temp (6.2) which uses the newer WLTP cycle. This cycle is intended to be a closer representation to economy achieved in the real world and is included for this transparency. NEDC figures are not from the older cycle but in fact are a derived back-correlation calculation from the WLTP test data. Some systems and protocols such as the 2020 CO₂ target will use this figure, and hence it is included for this, and also to enable comparison to outgoing models.

[#]Fuel consumption data and CO₂ emission data are determined using the Worldwide harmonized Light vehicles Test Procedure (WLTP), and the relevant values are translated back to allow the comparability into NEDC, according to regulations R (EC) No. 715/2007, R (EU) No. 2017/1153 and R (EU) No. 2017/1151. The values do not take into account in particular use and driving conditions, equipment or options and may vary depending on the format of tyres. For more information on official fuel consumption and CO₂ emission values, please read the guidelines at <http://vanfueldata.dft.gov.uk/>

^{##}Fuel consumption and CO₂ emission data are determined according to the WLTP test cycle. Full data relating to WLTP test cycles can be found at: www.vauxhall.co.uk/wltp

FEATURES/OPTIONS

SAFETY

	Option code	Edition	Price (£) exc. VAT	Price (£) inc. VAT
Driver/passenger airbags		●		
• Driver's airbag				
• Front passengers' airbag with deactivation switch – Not available with Convenience Pack option.	AK5	○	260.00	312.00
Stability		●		
• Electronic Stability Programme-plus (ESP-plus) with traction control and side wind assist – Works in conjunction with the vehicle's electronic braking and engine systems to keep the vehicle stable in many different situations. ESP monitors a variety of inputs to determine when the vehicle starts to lose traction, it can then immediately respond by varying the brake pressure between up to three wheels and adjust the engine output to help correct the loss of traction and improve stability.				
Braking		●		
• Four-channel Anti-lock Braking System (ABS) – Prevents the vehicle's wheels from locking up under heavy braking by momentarily reducing brake pressure at the appropriate wheel, ensuring that you can maintain control of the steering.				
• Emergency brake assist – When emergency braking is detected the vehicle Automatically applies the maximum possible braking assistance.				
• Electronic brakeforce distribution – Automatically apportions the optimum braking force to each wheel.				
• Hill start assist – Briefly maintains rear brake pressure to stop the vehicle rolling back on an incline.				
Advanced emergency brake assist		●		
– Standard on RWD DRW 4500 models.				
Advanced Safety Assist Pack	XiFJ	○	550.00	660.00
• High beam headlight assist • Lane departure warning • Side blind spot alert				
Bulkhead		○		
• Full-height steel bulkhead without window – Standard on Panel Van/optional on Platform Cab models.	AX6	○	135.00	162.00
• Full-height ABS plastic bulkhead with window – Doublecab only.		●		
• Full-height steel bulkhead with window – Standard on Chassis/Crew Cab models. Optional on Panel Van/Platform Cab models.	AX9	○	50.00	60.00

● = Standard equipment. ○ = Optional at extra cost.

FEATURES/OPTIONS

SECURITY

	Option code	Edition	Price (£) exc. VAT	Price (£) inc. VAT
Standard security features • Electronic engine deadlock immobiliser • Steering column lock • Secure fuel filler flap		●		
• Internal lockable rear and sliding side-access doors • Under-floor spare wheel storage – Wind down only when rear doors opened. Standard on Panel Van/Doublecab.		●		
Remote control door locking (features depending on body type) • Selective door locking • Two keys with integral remote • Door deadlocks		●		
• Third key with integral remote	K69	○	60.00	72.00
Security alarm system • Engine compartment protection • Ultrasonic detectors in load area • Siren • Thatcham Category 1 approved (TCL1-101/1103) – Not available on Platform Cab models.	UA6	○	370.00	444.00

● = Standard equipment. ○ = Optional at extra cost.

FEATURES/OPTIONS

HEATING AND VENTILATION

	Option code	Edition	Price (£) exc. VAT	Price (£) inc. VAT
Cab heating • Four-speed fan • Illuminated controls • Four adjustable facia vents • Windscreen demist vents • Side window demist vents		●		
Air conditioning • Air recirculation facility • Pollen filter • Illuminated controls • Chilled glovebox facility	C60	○	700.00	840.00

CABIN STORAGE

Accessory sockets • 12-volt accessory socket beside gear lever		●		
Facia storage • Driver's coin, ticket and card holder • Driver's oddments storage • Lidded glovebox (11-litre capacity) • Central drinks holder • Front passenger semi-covered document tray		●		
Front door pockets • Large door pocket with capacity for a 2-litre drink bottle • Oddments pocket		●		
Additional storage • Overhead storage shelf		●		

Please note: The air conditioning in vehicles with N1, N2 or M2 type approval relies upon fluorinated greenhouse gases (R134a) for its functioning. The front system contains a quantity of overall 580g of R 134a, which corresponds to a CO₂ equivalent of 0.83 tons. The front and rear system in versions with up to 9-seats contains a quantity of overall 1,100g of R 134a, which corresponds to a CO₂ equivalent of 1.57 tons. The front and rear system in versions with more than 16-seats contains a quantity of overall 1,700g of R 134a, which corresponds to a CO₂ equivalent of 2.43 tons. The global warming potential amounts to 1430. Information acc. to R (EU) No. 517/2014.

● = Standard equipment. ○ = Optional at extra cost.

FEATURES/OPTIONS

COMFORT AND SEATING

	Option code	Edition	Price (£) exc. VAT	Price (£) inc. VAT
Comfort <ul style="list-style-type: none"> • Height-adjustable steering wheel • Facia-mounted gear lever • Floor-mounted handbrake lever • Pulse cloth seat trim • Vinyl floor covering • Inertia-reel lap and diagonal seatbelts • Height-adjustable outer front seatbelts 		●		
Vinyl seat trim <ul style="list-style-type: none"> • Grey vinyl seat trim – Not available on Doublecab models or with Convenience Pack/air-suspended driver's seat options/ dual front passengers' multi-function office bench seat. 	TAVX	○	50.00	60.00
Driver's seat <ul style="list-style-type: none"> • Height • Reach • Backrest recline • Height-adjustable padded head restraint • Driver's seat armrest 		●		
'Comfort' driver's seat <ul style="list-style-type: none"> • Lumbar adjustment • Height • Reach • Backrest recline • Height-adjustable padded head restraint • Centre fold-away armrest – Not available on L4 R3500 DRW Dropside models. 	B21	○	135.00	162.00
Dual front passengers' bench seat (not available on L3H1 F3500 Crew Cab Tipper models) <ul style="list-style-type: none"> • Fixed position bench seat and backrest • Height-adjustable outer front padded head restraint • Fixed centre seat padded head restraint – Not available on Doublecab models. 		●		
Dual front passengers' multi-function office bench seat (not available on L3H1 F3500 Crew Cab Tipper models) <ul style="list-style-type: none"> • Dual front passengers' bench seat • Centre seat features flat-folding backrest with twin drinks holders, flat work surface and swivelling tray • Underseat storage – Standard on Doublecab models. 		●		

● = Standard equipment. ○ = Optional at extra cost.

FEATURES/OPTIONS

COMFORT AND SEATING CONTINUED

	Option code	Edition	Price (£) exc. VAT	Price (£) inc. VAT
Single front passenger's seat (standard on L3H1 F3500 Crew Cab Tipper models) • Reach • Backrest recline • Height-adjustable padded head restraint – Not available with Convenience Pack option.	AE1	○	60.00	72.00
Convenience Pack (Panel Van) • 'Comfort' driver's seat with armrest and lumbar support • Multi-function office bench seat with folding seat back on centre passenger seat including swivelling work tray and tilt forward seat cushions with underseat storage • Retractable A4 facia document clip • 'One-touch down' facility for driver's electrically operated window • Bulkhead soundproofing – Not available when single front passenger's seat, front passengers' airbag or vinyl seat trim are specified.	XHIA	○	450.00	540.00
Doublecab rear seating • Four-individually contoured rear seats • Inertia-reel lap and diagonal seatbelts • Padded head restraints • Integrated storage nets and cup holders • Full-length tray under rear seat cushion		●		

● = Standard equipment. ○ = Optional at extra cost.

FEATURES/OPTIONS

DRIVER ASSISTANCE

	Option code	Edition	Price (£) exc. VAT	Price (£) inc. VAT
Windscreen wipers • Rain-sensitive windscreen wipers • Electric screenwash		●		
Parking assistance • Surround rear vision – Panel Van/Doublecab models.	5J6	○	850.00	1,020.00
• Front and rear parking distance sensors – Not available on Chassis/Crew/Platform Cab models or derivatives.	UD5	○	300.00	360.00
• Rear-view camera • Front and rear parking distance sensors – Not available on Chassis/Crew/Platform Cab models or derivatives.	UE5	○	450.00	540.00
• Rear parking distance sensors – Not available on Chassis/Crew/Platform Cab models or derivatives.	UD7	○	275.00	330.00
• Nearside blind spot/junction mirror located in front passenger sunvisor		●		
Cruise control, speed limiter and multi-function trip computer • Cruise control • Trip odometer • Vehicle range based on remaining fuel • Average speed • Average fuel economy • Instantaneous fuel economy • Driving time	K34	○	260.00	312.00
Speed limiter – These are factory-fitted speed limiters that cannot be adjusted by driver. • Choice of three speeds: 56mph/62mph/68mph – 56mph speed limiter standard on RWD DRW 4500 models.	KYJ (56mph) KYK (62mph) KYL (68mph)	○	85.00	102.00

● = Standard equipment. ○ = Optional at extra cost.

FEATURES/OPTIONS

DRIVER INFORMATION

	Option code	Edition	Price (£) exc. VAT	Price (£) inc. VAT
Instrumentation <ul style="list-style-type: none"> • Speedometer • Rev counter • Digital fuel gauge with low fuel warning light • Coolant temperature gauge with warning light 		●		
ECO features <ul style="list-style-type: none"> • Shift-up indicator (manual models) – Indicates when to change gear for optimum fuel economy 		●		
Driver information display <ul style="list-style-type: none"> • Monochrome display located in instrument cluster • Odometer • Service-due indicator • Displays trip computer data (when fitted) 		●		
Central fascia display <ul style="list-style-type: none"> • Audio information • Digital clock with Automatic RDS time adjustment • Outside air temperature with ice warning function • Additional features and location dependent on infotainment unit (see Infotainment for details) 		●		
Warning indicators <ul style="list-style-type: none"> • Low oil level, low brake fluid, brake pad wear, battery, fuel filter, low AdBlue® level, seatbelt warning and doors open 		●		
Smart digital tachograph <ul style="list-style-type: none"> • CANbus interface • Odometer display is changed from miles to kilometres – Standard on RWD DRW 4500 models. – Important: The digital tachograph must be specified at time of ordering as it cannot be fitted retrospectively. Option price does not include calibration which must be carried out at an approved tachograph centre within 14 days of the vehicle's registration. Please note: The legislation regarding the use of tachographs is complex and operators should seek independent advice or speak to the Commercial Vehicle specialist at your Vauxhall Retailer to ensure compliance. Alternatively your local DVLA office will also be able to provide clarification of the relevant legislation. 	TGF	○	535.00	642.00

● = Standard equipment. ○ = Optional at extra cost.

FEATURES/OPTIONS

INFOTAINMENT

	Option code	Edition	Price (£) exc. VAT	Price (£) inc. VAT
<p>CD 16 BT USB</p> <p>Onboard features:</p> <ul style="list-style-type: none"> • DAB digital radio • AM/FM stereo radio with 18-station presets • CD/MP3 CD player • High-level display • RDS with Traffic Programme • Two 15-watt speakers <p>Media connections:</p> <ul style="list-style-type: none"> • USB connection with iPod control • Aux-in socket • Bluetooth® audio streaming (A2DP Profile) <p>Mobile phone portal:</p> <ul style="list-style-type: none"> • Bluetooth® connectivity • Vehicle microphone • Phone book access – Contacts/last calls/missed calls etc. (features dependent on mobile phone) 		●		
<p>Multimedia Navi Pro</p> <p>Onboard features:</p> <ul style="list-style-type: none"> • 7-inch colour touchscreen • AM/FM stereo radio with 15 Station presets • DAB Digital radio • RDS with Traffic Programme • 20 watts per channel output • Four speakers (eight on Doublecab models) <p>Navigation features:</p> <ul style="list-style-type: none"> • Satellite navigation system • 3D street level mapping • European coverage • Structured or one-box destination entry • Points-of-interest search • Eco routing • Map updates via USB <p>Wi-fi enabled connected navigation features:</p> <ul style="list-style-type: none"> • Local weather information • Nearby fuel station display • Local address search and contact info for points of interest <p>Media connections:</p> <ul style="list-style-type: none"> • USB connection with iPod control • Bluetooth® A2DP audio streaming (Advanced Audio Distribution Profile) <p>Mobile phone portal:</p> <ul style="list-style-type: none"> • Bluetooth® connectivity • Handsfree calls via steering wheel controls • Vehicle microphone • Phone book access – Contacts/last calls/missed calls etc. are mirrored on the display and are easily navigated using the touchscreen (features dependent on mobile phone). <p>Smartphone interface:</p> <ul style="list-style-type: none"> • Apple CarPlay™ • Android Auto™ – Smartphone projection that allows operations via voice command, touchscreen and buttons to control apps and music playback. 	1OR	○	760.00	912.00
<p>Additional features</p> <ul style="list-style-type: none"> • Steering column mounted audio controls • Flexible roof-mounted aerial 		●		

*Additional terms and conditions apply to connected services, including customer acceptance of location sharing prior to activation.

● = Standard equipment. ○ = Optional at extra cost.

FEATURES/OPTIONS

LOAD ACCESS

	Option code	Edition	Price (£) exc. VAT	Price (£) inc. VAT
Nearside access Nearside side-access door: • Nearside sliding side-access door • Unglazed – Standard on Panel Van.		●		
Nearside side-access door with fixed windows: • Fixed window to standard nearside sliding side-access door (£200) • Fixed window to opposite offside body panel (£165) – Standard on Doublecab.		▲	365.00	438.00
Nearside side-access door with sliding windows: • Sliding window to standard nearside sliding side-access door (£335) • Sliding window to opposite offside body panel (£335)		▲	670.00	804.00
Offside access Offside side-access door: • Offside sliding side-access door • Unglazed – Panel Van only.		▲	310.00	372.00
Offside side-access door with fixed windows: • Fixed window to standard nearside sliding side-access door (£200) • Offside side-access door (£310) • Fixed window to offside side-access door (£165)		▲	675.00	810.00
Offside side-access door with sliding windows: • Sliding window to standard nearside sliding side-access door (£335) • Offside side-access door (£310) • Sliding window to offside side-access door (£335)		▲	980.00	1,176.00

● = Standard equipment. ▲ = Please refer to ordering guide.

FEATURES/OPTIONS

LOAD ACCESS CONTINUED

	Option code	Edition	Price (£) exc. VAT	Price (£) inc. VAT
Rear access				
Rear solid doors: • Twin rear doors • 90°/180° opening		●		
• Twin rear doors • 270° opening – Not available on L1 models	7U4	○	285.00	342.00
Rear glazed doors: • Glazed rear doors • 90°/180° opening	J1X	○	110.00	132.00
• Heated rear windows – Only available with glazed rear doors.	C49	○	110.00	132.00
Glazed Pack				
• Fixed window to standard nearside side-access door • Fixed window to opposite offside body panel • Rear glazed doors • Rear glazed side panels	A10	○	430.00	516.00

● = Standard equipment. ○ = Optional at extra cost.

FEATURES/OPTIONS

LOAD RESTRAINT

	Option code	Edition	Price (£) exc. VAT	Price (£) inc. VAT
Load anchorage <ul style="list-style-type: none"> • Fixed floor-mounted load restraint lashing eyes (L1 models x 6, L2/L3 models x 8, L4 models x 10) • Nearside/offside rear door column load restraint lashing eyes 		●		
Load lining <ul style="list-style-type: none"> • Full-height plywood load lining • Plywood wheel arch protection - Not available with glazed side-access door(s). Only available with resin-coated plywood load floor covering. 	N20	L1 H1 ○	590.00	708.00
		L1 H2 ○	600.00	720.00
		L2 ○	615.00	738.00
		L3 ○	630.00	756.00
		L4 ○	780.00	936.00
<ul style="list-style-type: none"> • Resin-coated plywood load floor covering – Panel Van only. 	B68	L1/L2 ○	330.00	396.00
		L3/L4 ○	370.00	444.00
Illuminated load area		●		

● = Standard equipment. ○ = Optional at extra cost.

FEATURES/OPTIONS

EXTERIOR CONVENIENCE/STYLING

	Option code	Edition	Price (£) exc. VAT	Price (£) inc. VAT
Exterior features • Integral steps in front bumper • Laminated windscreen • Body side-protection mouldings		●		
• Front and rear mudflaps	Q8H	○	80.00	96.00
• Rear bumper with integral step – Standard on RWD/RWD DRW Panel Van/Doublecab models. Optional on FWD Panel Van/Doublecab models.	VF6	○	260.00	312.00
Windows • Electrically operated front windows		●		
Door mirrors • Foldable electrically adjustable/heated door mirrors • Wide-angle mirror on driver's side • Integrated side-repeat indicators		●		
Extendable door mirrors (Chassis, Crew and Platform Cab) • Long arm exterior mirrors – Long arm exterior mirrors should be applied to any vehicle with an overall width of 2.17 to 2.35 metres.	DBE	○	85.00	102.00
Paint finish • Special paint – Restrictions apply, please consult your Retailer for details.		○	At extra cost	

EXTERIOR LIGHTING

Standard lighting • Automatic lighting control with tunnel detection • Lights-on audible warning • Manual headlight beam levelling • Twin reversing lights • Hazard warning lights • Rear fog lights • Centre rear brake light (excluding Chassis/Crew/Platform Cab models or derivatives) • Side-repeater in exterior mirrors		●		
• Front fog lights – Standard on 4500 models.	T3U	○	105.00	126.00

● = Standard equipment. ○ = Optional at extra cost.

FEATURES/OPTIONS

MECHANICAL

	Option code	Edition	Price (£) exc. VAT	Price (£) inc. VAT																		
<p>Transmission</p> <p>Six-speed manual gearbox: FWD models: • Transverse engine/gearbox • L1/L2/L3 models RWD/RWD DRW models: • Longitudinal engine/gearbox • L3/L4 models</p>		●																				
<p>Tecshift six-speed transmission: Tecshift transmission adds electronic control for both the clutch and gear selection to the standard six speed transmission.</p> <ul style="list-style-type: none"> • Electronic clutch control – Tecshift Automatically operates the clutch, meaning that there is no clutch pedal and the vehicle can be driven by an ‘Automatic-only’ driving licence holder. • Electronic gear selection – Tecshift also controls gear selection, leaving the driver with two gear-shifting options. <ul style="list-style-type: none"> – Automatic or manual. • Automatic mode – The driver selects forward or reverse gear and Tecshift does everything else, just like an Automatic gearbox. • Manual mode – The driver can change gear sequentially by pushing the lever forward (higher gear) or pulling it backwards (lower gear). • A ‘kickdown’ function – Going through two or more gears – is also possible in manual mode 		○	See price pages																			
<p>Steering</p> <ul style="list-style-type: none"> • Power-assisted rack and pinion system • Turns lock-to-lock: 3.7 <p>Turning circles</p> <table border="1"> <thead> <tr> <th></th> <th>Kerb-to-kerb</th> <th>Wall-to-wall</th> </tr> </thead> <tbody> <tr> <td>FWD L1</td> <td>12.0m (39.3ft.)</td> <td>12.5m (41.0ft.)</td> </tr> <tr> <td>FWD/RWD/RWD DRW L2</td> <td>13.6m (44.6ft.)</td> <td>14.1m (46.2ft.)</td> </tr> <tr> <td>FWD L3</td> <td>15.7m (51.5ft.)</td> <td>16.2m (53.1ft.)</td> </tr> <tr> <td>RWD/RWD DRW L3</td> <td>13.6m (44.6ft.)</td> <td>14.1m (46.2ft.)</td> </tr> <tr> <td>RWD/RWD DRW L4</td> <td>15.7m (51.5ft.)</td> <td>16.2m (53.1ft.)</td> </tr> </tbody> </table>		Kerb-to-kerb	Wall-to-wall	FWD L1	12.0m (39.3ft.)	12.5m (41.0ft.)	FWD/RWD/RWD DRW L2	13.6m (44.6ft.)	14.1m (46.2ft.)	FWD L3	15.7m (51.5ft.)	16.2m (53.1ft.)	RWD/RWD DRW L3	13.6m (44.6ft.)	14.1m (46.2ft.)	RWD/RWD DRW L4	15.7m (51.5ft.)	16.2m (53.1ft.)		●		
	Kerb-to-kerb	Wall-to-wall																				
FWD L1	12.0m (39.3ft.)	12.5m (41.0ft.)																				
FWD/RWD/RWD DRW L2	13.6m (44.6ft.)	14.1m (46.2ft.)																				
FWD L3	15.7m (51.5ft.)	16.2m (53.1ft.)																				
RWD/RWD DRW L3	13.6m (44.6ft.)	14.1m (46.2ft.)																				
RWD/RWD DRW L4	15.7m (51.5ft.)	16.2m (53.1ft.)																				
<p>Brakes</p> <p>Front ventilated disc brakes: • FWD/RWD/RWD DRW: 302mm x 28mm</p> <p>Rear disc brakes: • FWD/RWD: 305mm x 12mm • RWD DRW: 305mm x 18mm</p>		●																				

● = Standard equipment. ○ = Optional at extra cost.

FEATURES/OPTIONS

MECHANICAL CONTINUED

	Option code	Edition	Price (£) exc. VAT	Price (£) inc. VAT
Fuel tank		●		
• 80 litres (17.6 gallons) capacity				
• 105 litres (23.1 gallons) capacity – Not available on Core Conversions (excluding L3 Box)	NH7	○	110.00	132.00
AdBlue® tank		●		
• 26 litres (5.7 gallons) capacity				
Towing				
• Tow bar with 13-pin electrics (does not suit trailers with LED lights) • Trailer stability programme – Unless specific exemptions apply, vehicles operated with a trailer, where the combined weight of the vehicle, trailer and payload exceeds 3500kg, require a digital tachograph. For trailers with LED lights use genuine Vauxhall Accessory tow bars which also include trailer stability programme. Not available on Aluminium Tipper L4 H1 RWD Crew Cab DRW models.	VR2/VTO	○	385.00	462.00
Electrical		●		
• 95Ah maintenance-free battery (105Ah on Tecshift models) • 185A alternator				
• Second battery – Requires six-pin electrical connector. Not available with single passenger seat options, spare wheel or Convenience Pack on FWD models.	OBC	○	485.00	582.00
CANbus interface				
Allows the vehicle's electrical systems to integrate with additional equipment – Standard on RWD DRW 4500 models.	KC6	○	135.00	162.00
Six-pin electrical connector for conversions				
– Standard on Droptside/Tipper.	KPD	○	60.00	72.00

● = Standard equipment. ○ = Optional at extra cost.

FEATURES/OPTIONS

MECHANICAL CONTINUED

	Option code	Edition	Price (£) exc. VAT	Price (£) inc. VAT
Front suspension • MacPherson type • Independent double wishbones • Coil springs • Telescopic dampers		●		
Rear suspension • Tubular axle • Telescopic dampers • Variable rate leaf springs FWD models: • Single leaf springs • Single rear wheels RWD models: • Double leaf springs • Single rear wheels RWD DRW models: • Triple leaf springs • Twin rear wheels		●		
Body Conversion Pack A (Chassis Cab) • Extended wiring loom • Six-pin connector for conversions • 16-pin connector for cab-based conversions	XZCM	○	95.00	114.00
Body Conversion Pack B (Crew and Platform Cab) • Extended wiring loom • Six-pin connector for conversions	XZCN	○	60.00	72.00

● = Standard equipment. ○ = Optional at extra cost.





FEATURES/OPTIONS

ADDITIONAL FEATURES

	Option code	Edition	Price (£) exc. VAT	Price (£) inc. VAT
<p>Tipper</p> <p>Tipper assembly:</p> <ul style="list-style-type: none"> • Five-stage chrome-plated underfloor ram • Sliding and internal self-lubricating components made of reinforced nylon and Teflon • Anti-vibration Teflon plates on a secondary frame <p>Tipper deck:</p> <ul style="list-style-type: none"> • Steel platform, powder coated in dark grey • Integrated cabin protection and ladder rack • 400mm anodised aluminium removable side and rear alloy panels with recessed hinges • Top and bottom hinged rear panel • Recessed side and tailboard operating levers • Removable rear posts • Galvanised fixing bolts • Automatically releasing rear panel during the rear tipping phase • Frame and cross-members in edged galvanised sheet <p>Electrics:</p> <ul style="list-style-type: none"> • Audible warning during operation • Fused power supply with isolator switch • Electro/hydraulic power pack • Side lights where required • Remote control on wander lead located behind driver's seat <p>Exterior:</p> <ul style="list-style-type: none"> • Additional half-height tool box on L3 Chassis Cab Tipper models (2100 x 650 x 750mm) • Rear mudflaps • Side-protection under-run bars – 4500 models only. <p>Load restraint:</p> <ul style="list-style-type: none"> • Eight integrated load lashing points conforming to DIN 75410 standards 		●		
<p>Dropside</p> <p>Exterior:</p> <ul style="list-style-type: none"> • Plywood load floor with non-slip resin surface coating • Integrated cabin protection and ladder rack • 400mm anodised aluminium removable side and rear alloy panels with recessed hinges • Removable rear posts • Integrated load lashing rings conforming to DIN 75410 standards • Rear mudguards • Galvanised fixing bolts • Side lights where required • Frame and cross-members in edged galvanised sheet • Side-protection under-run bars – 4500 models only. 		●		
<p>Box Van</p> <p>Interior/exterior:</p> <ul style="list-style-type: none"> • Polyester lightweight box with smooth external appearance • Aluminium frame • Long arm exterior mirrors • 18mm plywood covered anti-slip floor • Twin rear 270° opening aluminium doors • Folding rear step fitted to offside 		●		
Rear roller shutter door	D5W	○	760.00	912.00

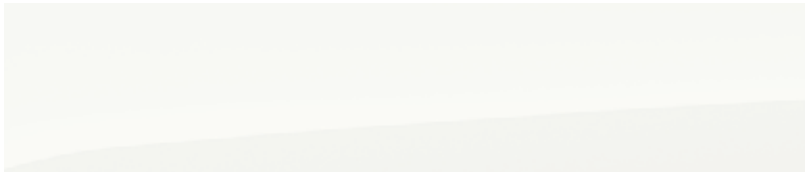
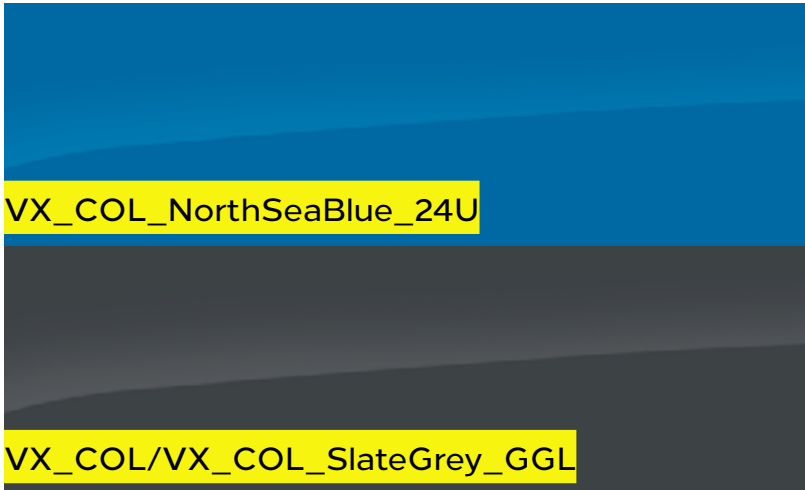
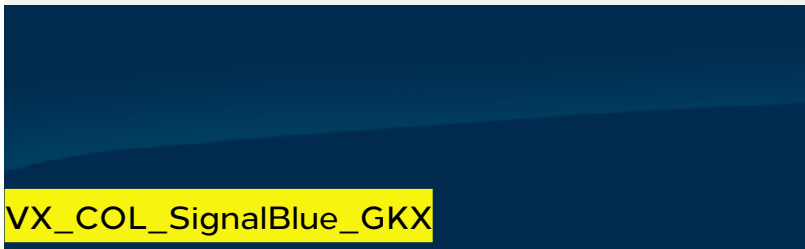
● = Standard equipment. ○ = Optional at extra cost.

EXTERIOR COLOURS

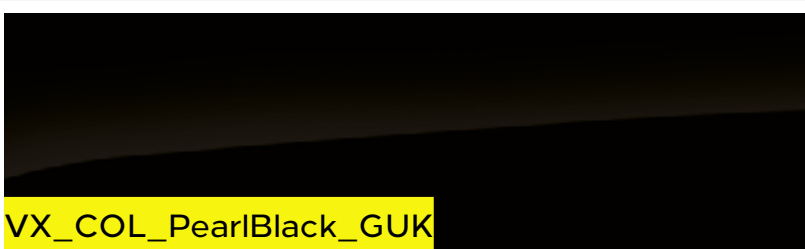
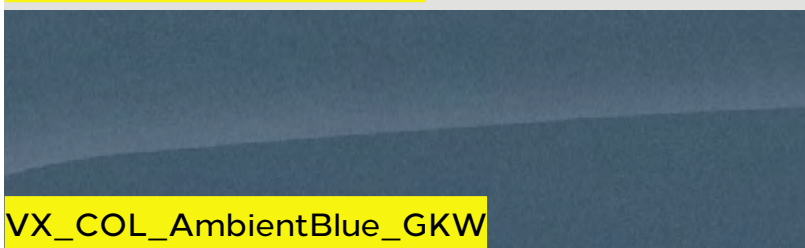
					Edition	Price (£) exc. VAT	Price (£) inc. VAT
Solid	 VX_COL_PolarWhite_GNY	Polar White (GNY)	 VX_COL_NorthSeaBlue_24U VX_COL/VX_COL_SlateGrey_GGL	North Sea Blue (24U)	●		
	 VX_COL_SignalBlue_GKX	Signal Blue (GKX)		Slate Grey (GGL)			
	 VX_COL_SaffronYellow_98U	Saffron Yellow (98U)					
Brilliant	 VX_COL_PoppyRed_74U	Poppy Red (74U)	 VX_COL_MandarinOrange_99U	Mandarin Orange (99U)	○	317.00	380.40
Two-coat	 VX_COL_HaloSilver_GKY	Halo Silver metallic (GKY)	 VX_COL_PearlBlack_GUK	Pearl Black metallic (GUK)	○	625.00	750.00
	 VX_COL_AmbientBlue_GKW	Ambient Blue metallic (GKW)					

The colours reproduced may vary slightly from the actual paint colour. As a result they should be used as a guide only. Your Vauxhall Retailer has a comprehensive display of our paint samples.
On Cab and Conversion variants the colours illustrated apply to the vehicle cab only.

● = Standard equipment. ○ = Optional at extra cost.

WHEELS AND TYRES





	Option code	Edition	Price (£) exc. VAT	Price (£) inc. VAT
FWD 2800/FWD 3300 models <ul style="list-style-type: none"> • 6.5J x 16-inch steel wheels • 215/65 R 16 tyres • Full-size spare wheel • Wheel centre covers 		●		
FWD 3500/3900 models <ul style="list-style-type: none"> • 6.5J x 16-inch steel wheels • 225/65 R 16 tyres • Full-size spare wheel • Wheel centre covers 		●		
RWD 3500 models <ul style="list-style-type: none"> • 7J x 16-inch steel wheels • 235/65 R 16 tyres • Full-size spare wheel • Wheel centre covers 		●		
RWD DRW 3500/RWD DRW 4500 models <ul style="list-style-type: none"> • 5.5J x 16-inch steel wheels • 195/75 R 16 tyres • Twin rear wheels • Full-size spare wheel 		●		

● = Standard equipment.

WHEELS AND TYRES

	Option code	Edition	Price (£) exc. VAT	Price (£) inc. VAT
All-season tyres - Continental Vanco Four Season 2 FWD models only: 225/65 R 16 - Not available on FWD 2800 models.	NRK	O	360.00	432.00
Full-diameter wheel covers - Not available on RWD DRW models.	QP9	O	60.00	72.00
Tyre inflation kit in lieu of spare wheel - Not available on RWD/RWD DRW models.	WTC	N/C	No-cost option	

Tyre Rating

Tyre size	Fuel efficiency group	Wet grip performance	External noise	
			Measured (dB)	Group
195/75 R 16	B	B	72	
215/65 R 16	B	B	71	
225/65 R 16	B-E	B-C	70	
235/65 R 16	C-E	B	70	

Tyre rating according to EU Regulation 1222/2009

O = Optional at extra cost. N/C = No-cost option.

DIESEL ENGINES

Engine (Front-wheel drive models)	2.3 (135PS) Turbo D BlueInjection	2.3 (150PS) Turbo D BlueInjection with S/S	2.3 (180PS) Turbo D BlueInjection with S/S
Capacity	2298cc	2298cc	2298cc
Maximum power	135PS (99kW) @ 3500rpm	150PS (110kW) @ 3500rpm	180PS (132kW) @ 3500rpm
Maximum torque	360Nm (266 lb.ft.) @ 1600rpm	385Nm (284 lb.ft.) @ 1750rpm	400Nm (295 lb.ft.) @ 1500-2750rpm
Configuration	4 cylinders, 4 valves per cylinder, double overhead camshafts	4 cylinders, 4 valves per cylinder, double overhead camshafts	4 cylinders, 4 valves per cylinder, double overhead camshafts
Fuel/induction system	Twin variable geometry turbochargers with intercoolers. Common rail fuel injection	Twin variable geometry turbochargers with intercoolers. Common rail fuel injection	Twin variable geometry turbochargers with intercoolers. Common rail fuel injection
Emission compliance	Euro 6D TEMP	Euro 6D TEMP	Euro 6D TEMP
WLTP fuel economy range - mpg (l/100km)	26.9 (10.5) - 31.4 (9.0)	27.4 (10.3) - 32.2 (8.8)	26.9 (10.5) - 31.4 (9.0)
WLTP CO ₂ emission range - g/km	276 - 236	270 - 230	277 - 235
Service interval	25,000 miles or two years (whichever occurs sooner)	25,000 miles or two years (whichever occurs sooner)	25,000 miles or two years (whichever occurs sooner)

Engine (Rear-wheel drive models*)	2.3 (130PS) Turbo D BlueInjection	2.3 (145PS) Turbo D BlueInjection with S/S	2.3 (165PS) Turbo D BlueInjection with S/S
Capacity	2298cc	2298cc	2298cc
Maximum power	130PS (96kW) @ 3500rpm	145PS (107kW) @ 3500rpm	165PS (120kW) @ 3500rpm
Maximum torque	330Nm (243 lb.ft.) @ 1500rpm	360Nm (266 lb.ft.) @ 1500rpm	380Nm (266 lb.ft.) @ 2000rpm
Configuration	4 cylinders, 4 valves per cylinder, double overhead camshafts	4 cylinders, 4 valves per cylinder, double overhead camshafts	4 cylinders, 4 valves per cylinder, double overhead camshafts
Fuel/induction system	Twin variable geometry turbochargers with intercoolers. Common rail fuel injection	Twin variable geometry turbochargers with intercoolers. Common rail fuel injection	Twin variable geometry turbochargers with intercoolers. Common rail fuel injection
Emission compliance	EuroVIId	EuroVIId	EuroVIId
Service interval	25,000 miles or two years (whichever occurs sooner)	25,000 miles or two years (whichever occurs sooner)	25,000 miles or two years (whichever occurs sooner)

S/S = Start/Stop. *RWD heavy-duty engines have no requirement to comply with WLTP legislation.

Vehicles with BlueInjection technology will need regular AdBlue® top-ups also between servicing requirements. An indicator integrated into the on-board computer will warn you when you need to top up. More information under www.vauxhall.co.uk/adblue
In accordance with regulations R (EC) No. 715/2007 and R (EC) No. 692/2008 (in the versions respectively applicable).

NEW MOVANO FWD PANEL VAN SPECIFICATIONS

Loadspace Dimensions	L1	L2	L3
Maximum length	2583 (101.7)	3083 (121.4)	3733 (147.0)
Maximum width	1765 (69.5)	1765 (69.5)	1765 (69.5)
Width between wheel arches	1380 (54.3)	1380 (54.3)	1380 (54.3)
Maximum height – H1	1700 (66.9)	–	–
Maximum height – H2	1894 (74.6)	1894 (74.6)	1894 (74.6)
Maximum height – H3	–	2144 (84.4)	2144 (84.4)

Loadspace Access	L1	L2	L3
Side door aperture height – H1	1581 (62.2)	–	–
Side door aperture height – H2/H3	1780 (70.1)	1780 (70.1)	1780 (70.1)
Side door aperture width	1050 (41.3)	1270 (50.0)	1270 (50.0)
Rear door aperture height – H1	1627 (64.0)	–	–
Rear door aperture height – H2/H3	1820 (71.7)	1820 (71.7)	1820 (71.7)
Rear door aperture width	1577 (62.1)	1577 (62.1)	1577 (62.1)
Loading height (unladen)	563 (22.2)	562 (22.1)	557 (21.9)

	L1 H1	L1 H2	L2 H2	L2 H3	L3 H2	L3 H3
Loadspace Volumes cu.m (cu.ft.)						
Panel Van – Maximum	7.8 (275)	8.6 (304)	10.8 (381)	12.3 (434)	13.0 (459)	14.8 (523)
Panel Van – VDA	7.0 (247)	–	9.4 (322)	–	11.3 (399)	–

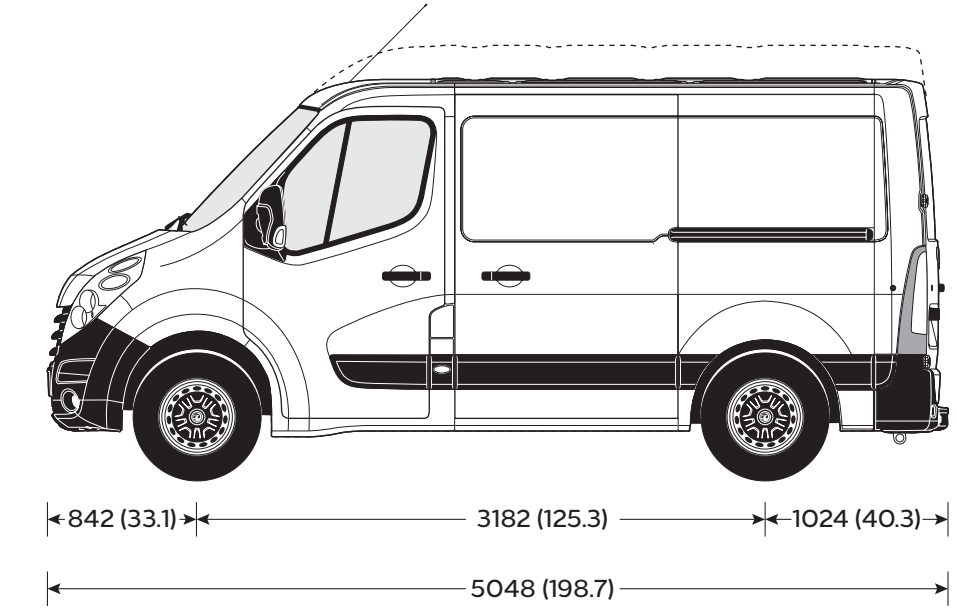
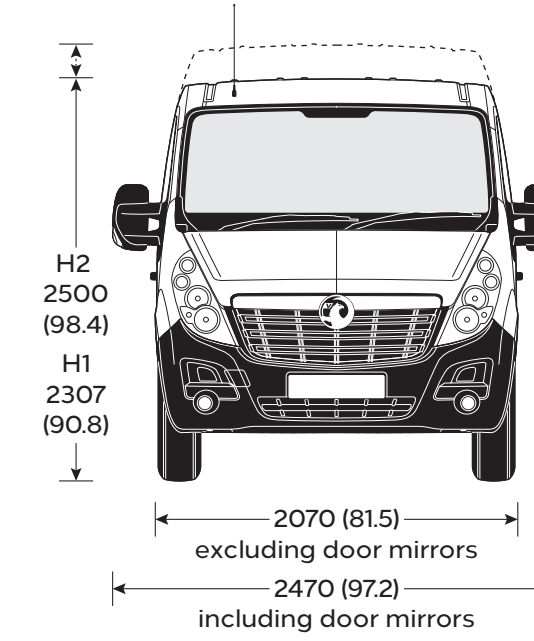

L1 H1/H2

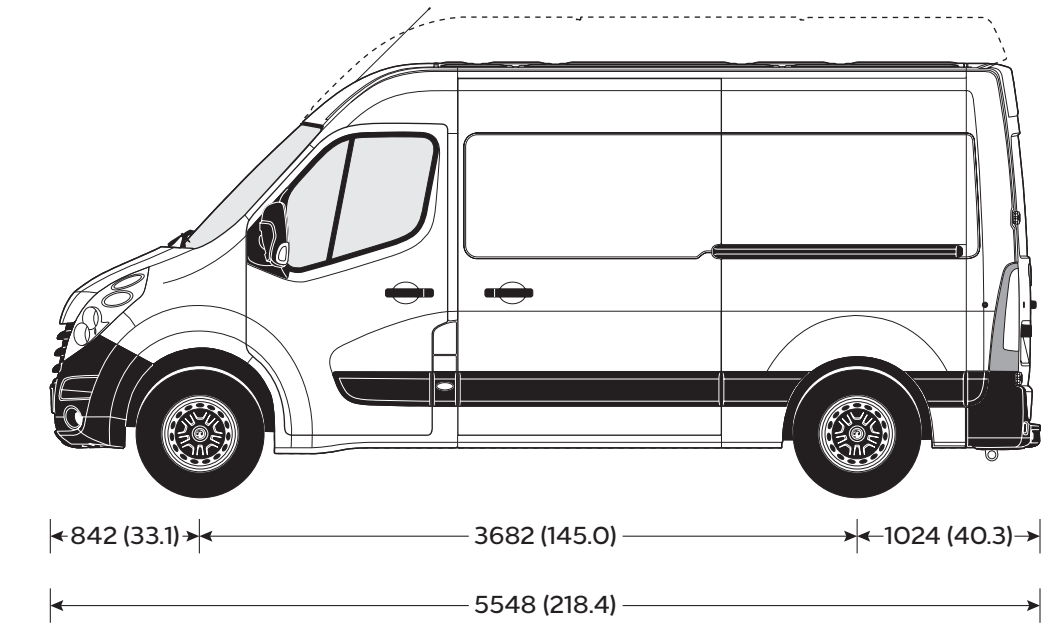
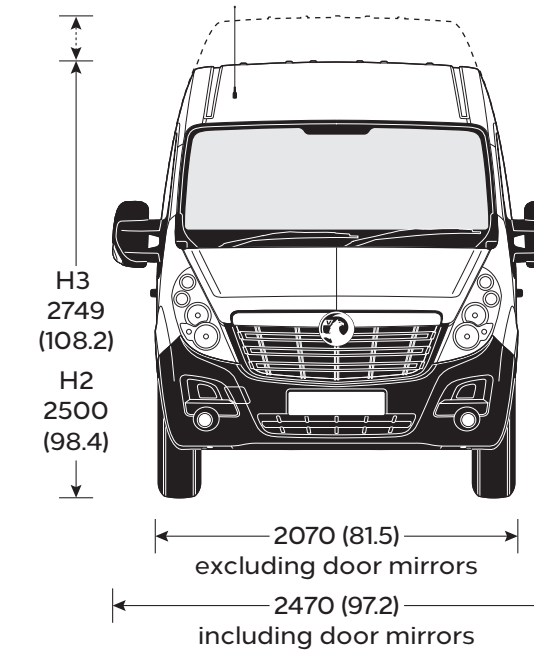

L2 H2/H3

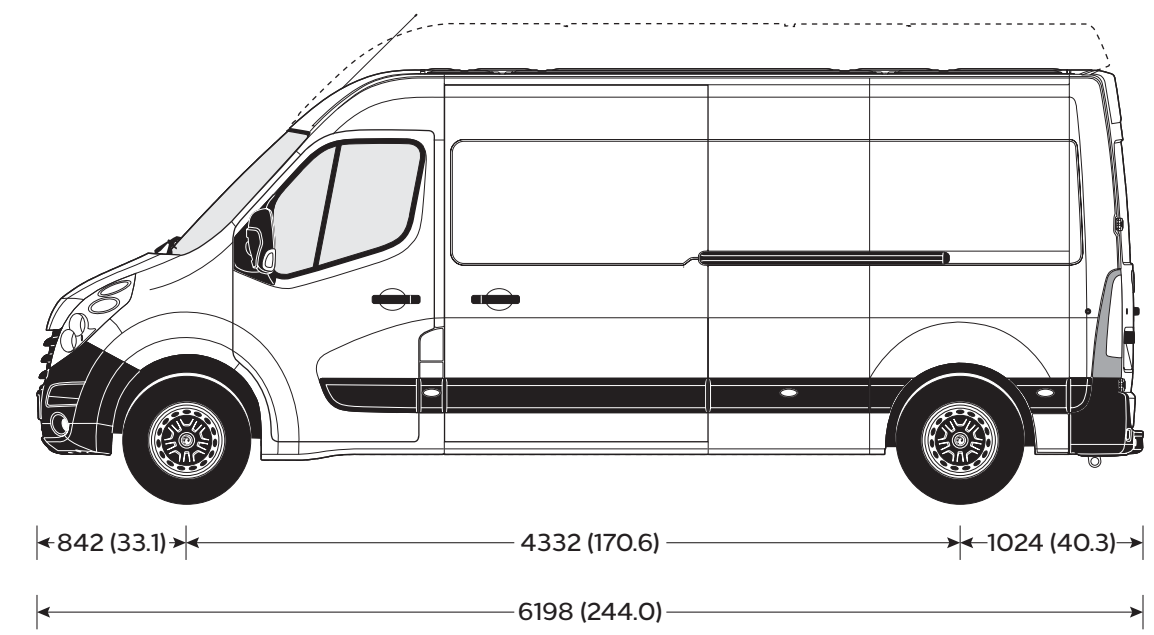
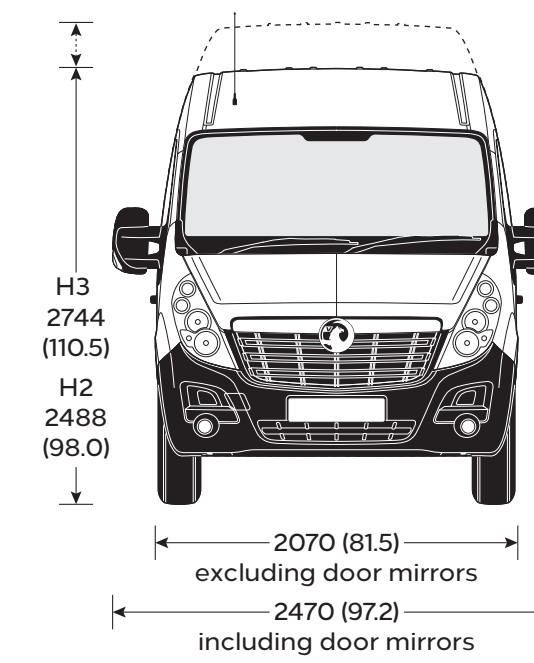

L3 H2/H3

NEW MOVANO FWD DOUBLECAB SPECIFICATIONS

Loadspace Dimensions	L2	L3
Maximum length at load floor	2175 (85.6)	2825 (111.2)
Maximum length behind rear seats	1990 (78.3)	2640 (103.9)
Maximum width	1765 (69.5)	1765 (69.5)
Width between wheel arches	1380 (54.3)	1380 (54.3)
Maximum height	1894 (74.6)	1894 (74.6)
Loadspace Access		
Side door aperture height	1780 (70.1)	1780 (70.1)
Side door aperture width	1270 (50.0)	1270 (50.0)
Rear door aperture height	1820 (71.7)	1820 (71.7)
Rear door aperture width	1577 (62.1)	1577 (62.1)
Loading height (unladen)	562 (22.1)	557 (21.9)
Loadspace Volumes cu.m (cu.ft.)		
Doublecab	6.9 (244)	9.0 (318)

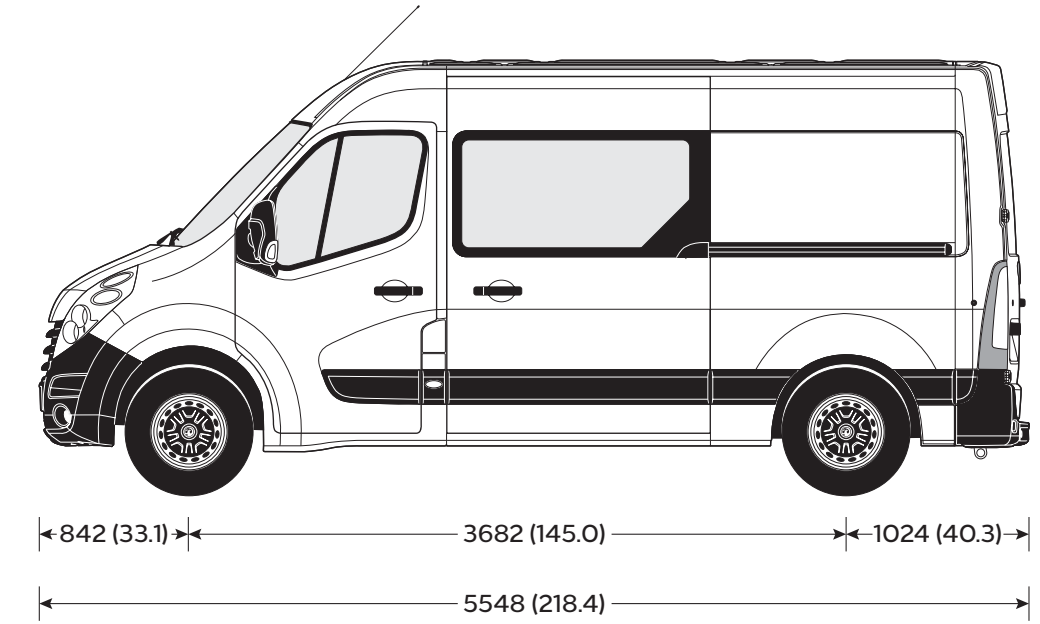
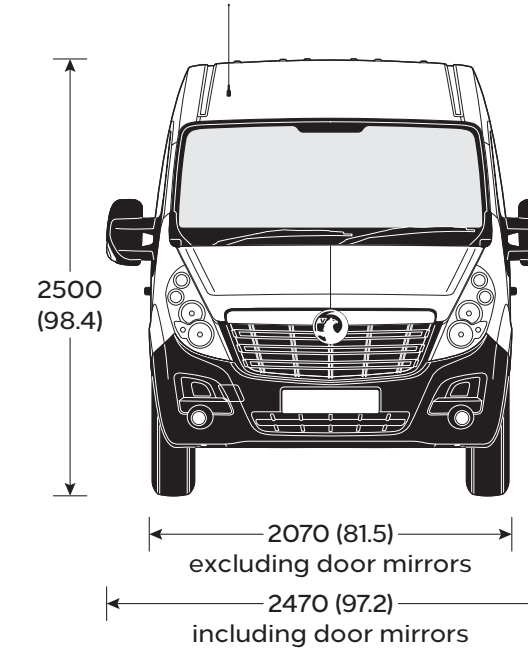

L2 H2

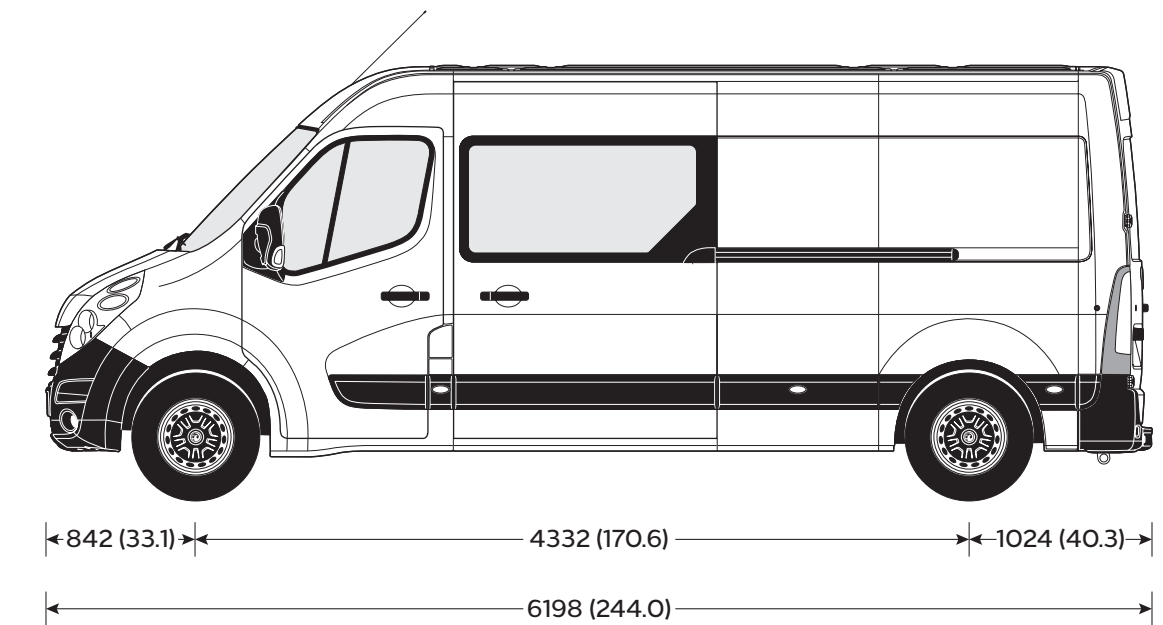
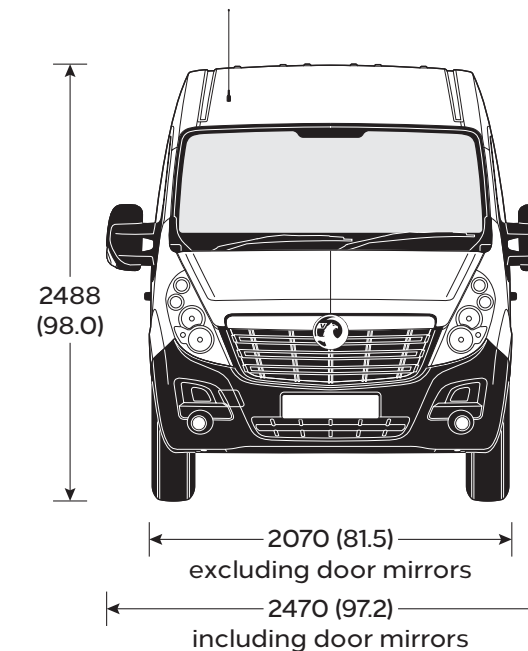
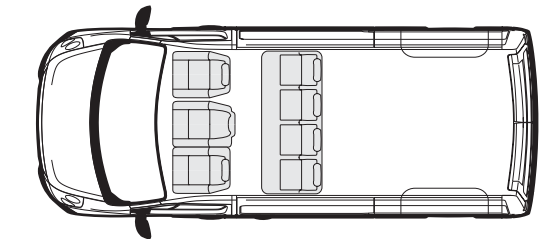

L3 H2

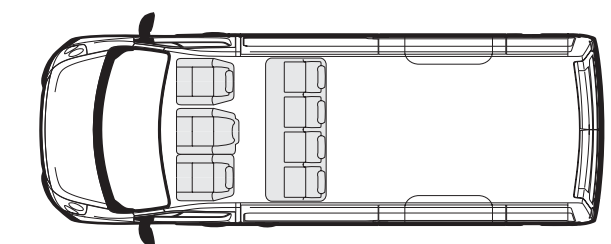

NEW MOVANO RWD DOUBLECAB SPECIFICATIONS

Loadspace Dimensions	L3
Maximum length at load floor	2825 (111.2)
Maximum length behind rear seats	2640 (103.9)
Maximum width	1765 (69.5)
Width between wheel arches	1380 (54.3)
Maximum height	1798 (70.8)
Loadspace Access	
Side door aperture height	1684 (66.3)
Side door aperture width	1270 (50.0)
Rear door aperture height	1724 (67.9)
Rear door aperture width	1577 (62.1)
Loading heights (unladen)	674 (26.5) – 696 (27.4)
Loadspace Volumes cu.m (cu.ft.)	
Doublecab	8.4 (297)

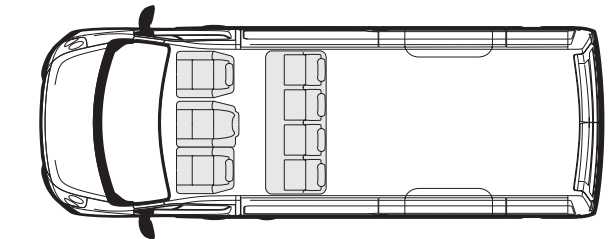
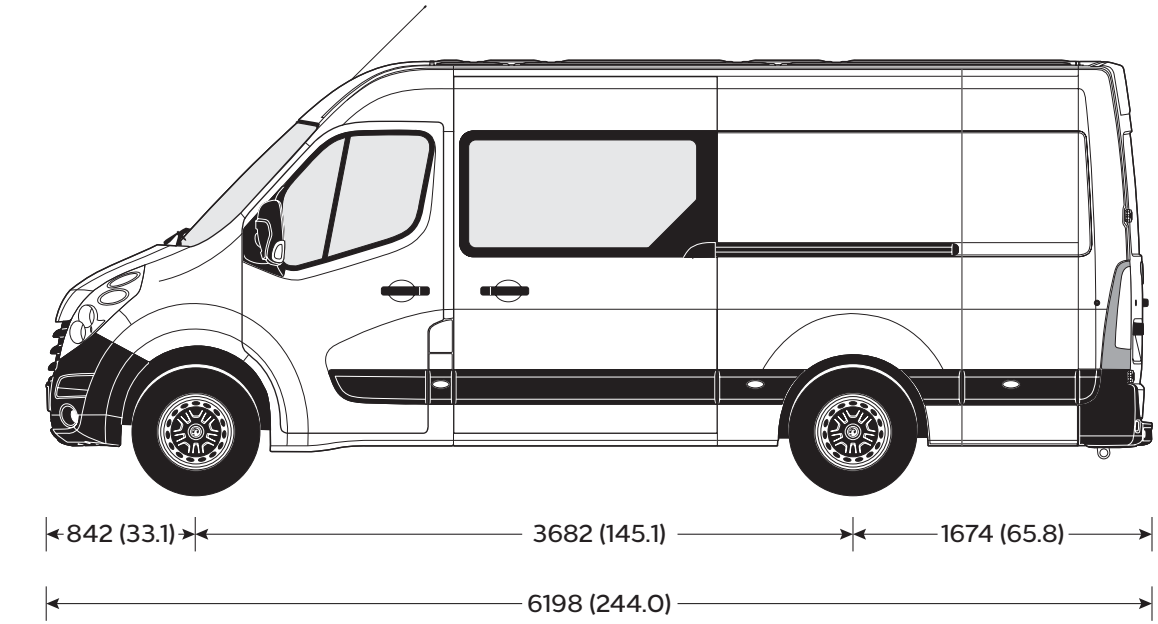
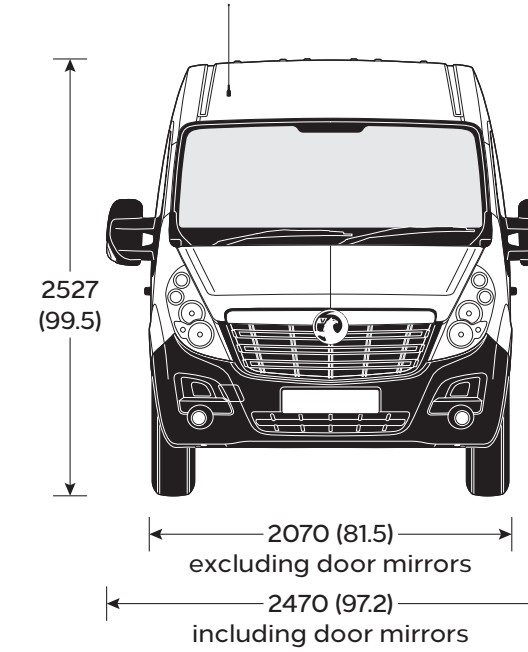

L3 H2

NEW MOVANO RWD PANEL VAN SPECIFICATIONS

Loadspace Dimensions	L3	L4		
Maximum length	3733 (147.0)	4383 (172.6)		
Maximum width	1765 (69.5)	1765 (69.5)		
Width between wheel arches	1380 (54.3)	1380 (54.3)		
Maximum height – H2	1798 (70.8)	1798 (70.8)		
Maximum height – H3	2048 (80.6)	2048 (80.6)		
Loadspace Access				
Side door aperture height	1684 (66.3)	1684 (66.3)		
Side door aperture width	1270 (50.0)	1270 (50.0)		
Rear door aperture height	1724 (67.9)	1724 (67.9)		
Rear door aperture width	1577 (62.1)	1577 (62.1)		
Loading heights (unladen)	696 (27.4) – 724 (28.5)	717 (28.2)		
Loadspace Volumes cu.m (cu.ft.)	L3 H2	L3 H3	L4 H2	L4 H3
Panel Van – Maximum	12.4 (438)	14.2 (501)	14.9 (526)	17.0 (600)
Panel Van – VDA	10.9 (385)	12.2 (431)	12.9 (456)	14.1 (498)

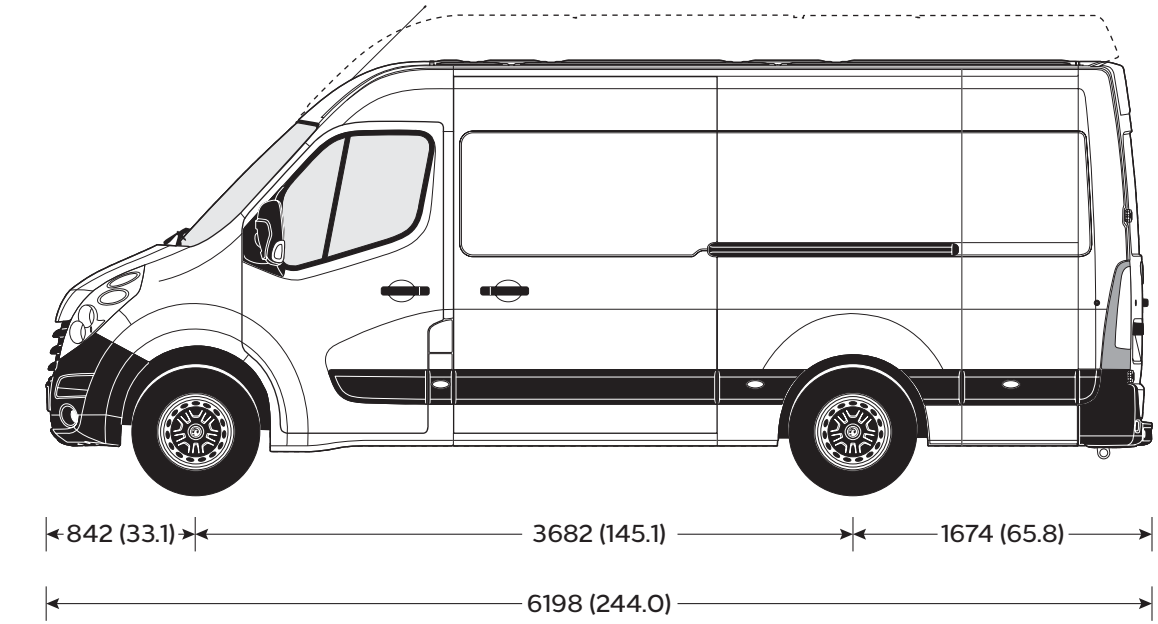
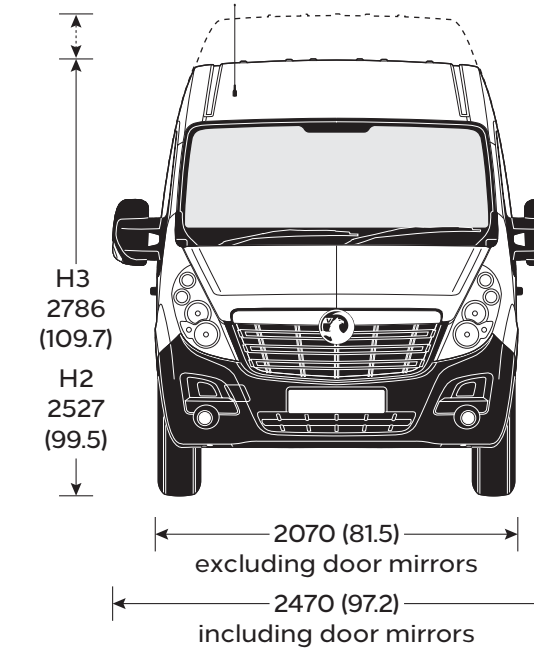

L3 H2/H3

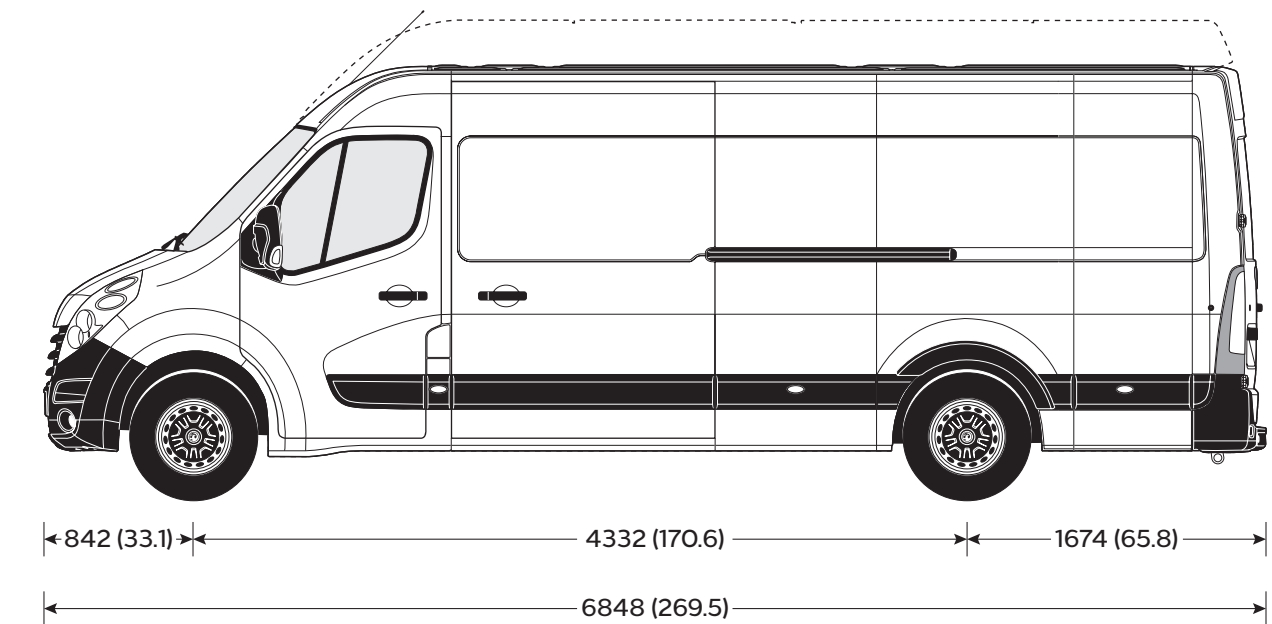
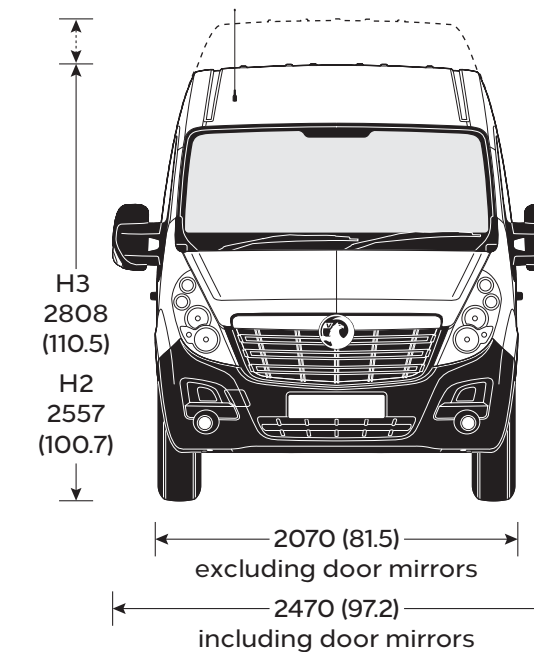

L4 H2/H3

NEW MOVANO RWD DRW PANEL VAN SPECIFICATIONS

Loadspace Dimensions	L3	L4		
Maximum length	3733 (147.0)	4383 (172.6)		
Maximum width	1765 (69.5)	1765 (69.5)		
Width between wheel arches	1080 (42.5)	1080 (42.5)		
Maximum height – H2	1798 (70.8)	1798 (70.8)		
Maximum height – H3	2048 (80.6)	2048 (80.6)		
Loadspace Access				
Side door aperture height	1684 (66.3)	1684 (66.3)		
Side door aperture width	1270 (50.0)	1270 (50.0)		
Rear door aperture height	1724 (67.9)	1724 (67.9)		
Rear door aperture width	1577 (62.1)	1577 (62.1)		
Loading heights	723 (28.4) – 724 (28.5)	717 (28.2)		
Loadspace Volumes cu.m (cu.ft.)	L3 H2	L3 H3	L4 H2	L4 H3
Panel Van – Maximum	12.4 (438)	14.2 (501)	14.9 (526)	17.0 (600)
Panel Van – VDA	10.7 (378)	12.0 (424)	12.7 (448)	13.9 (491)

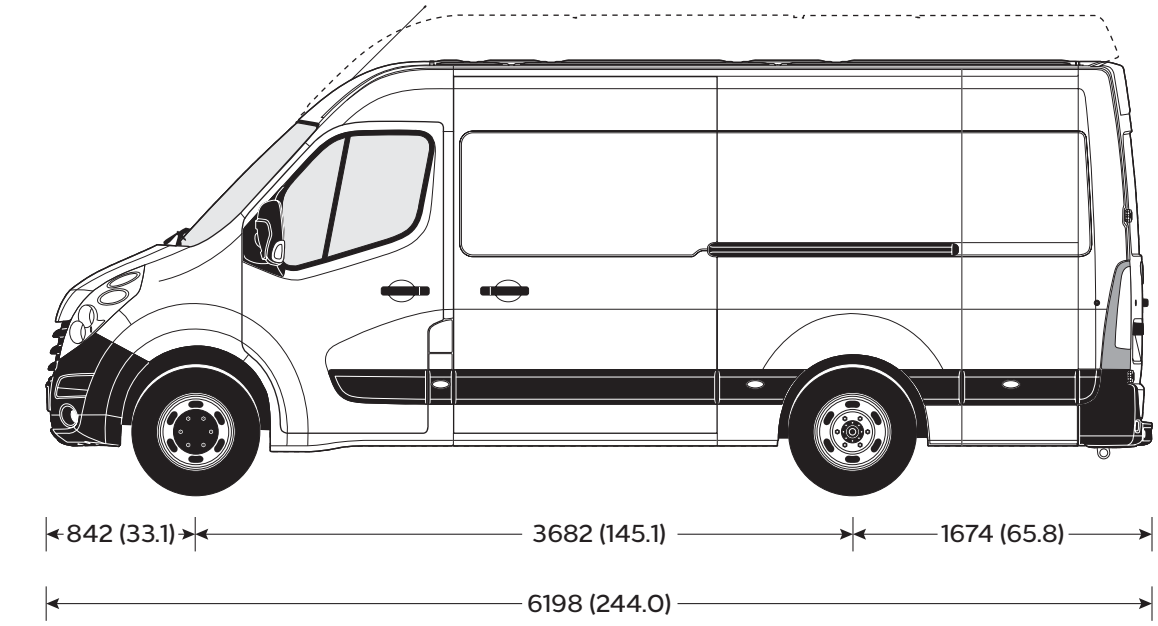
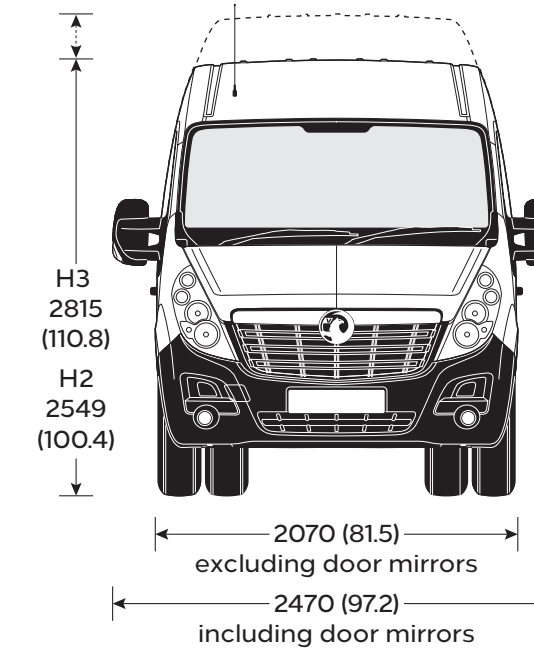

L3 H2/H3

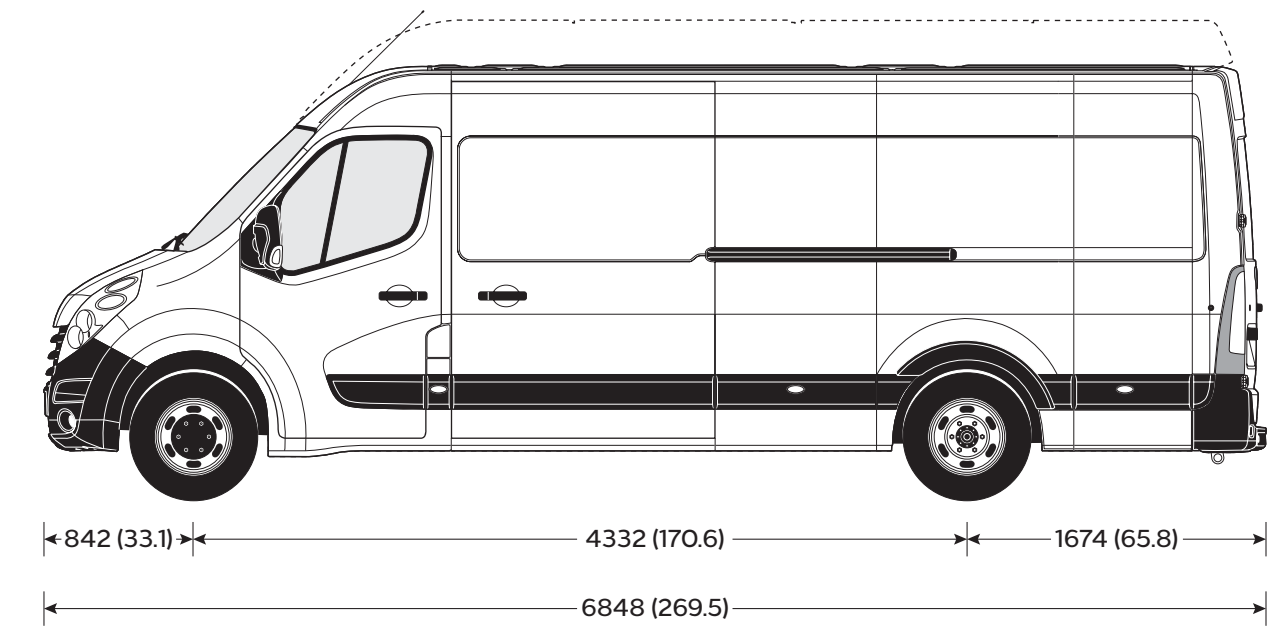
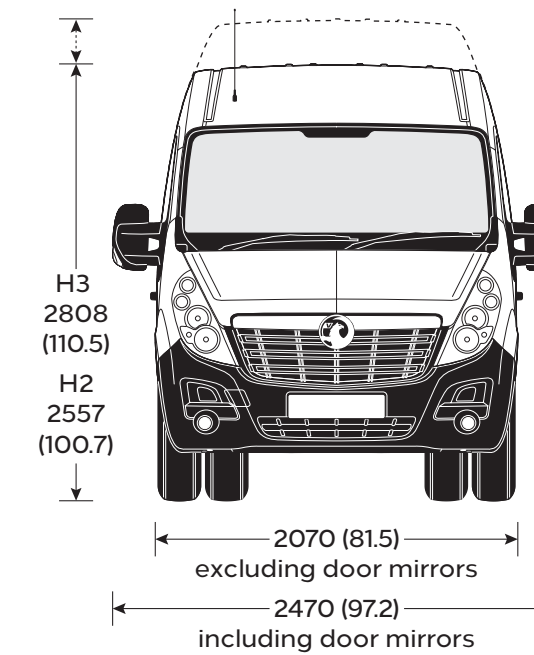

L4 H2/H3

NEW MOVANO TIPPER SPECIFICATIONS

Loadspace Dimensions	L2 FWD	L2 RWD DRW	L3 RWD DRW
Maximum length	3205 (126.2)	3205 (126.2)	3105 (122.2)
Maximum width	2040 (80.3)	2040 (80.3)	2040 (80.3)
Body side height	400 (15.7)	400 (15.7)	400 (15.7)
Loading height (unladen)	1090 (42.9)	1090 (42.9)	1090 (42.9)
Load area sq.m (sq.ft.)	6.5 (69.4)	6.5 (69.4)	6.3 (68.2)

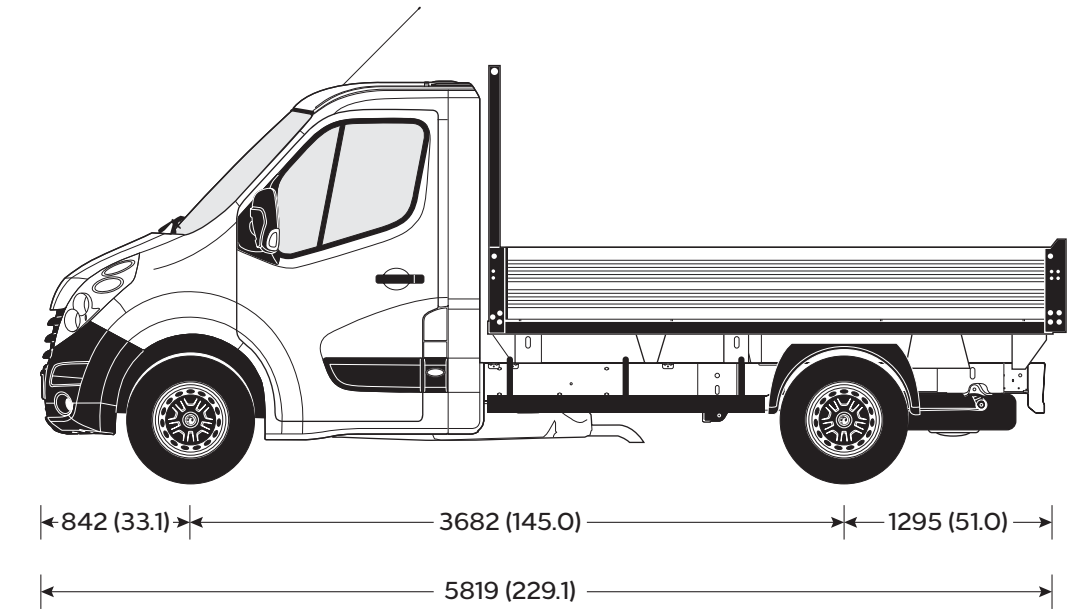
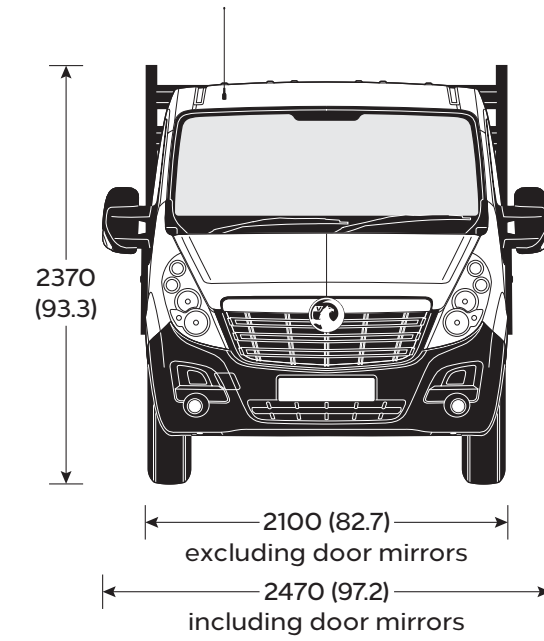

L2 FWD

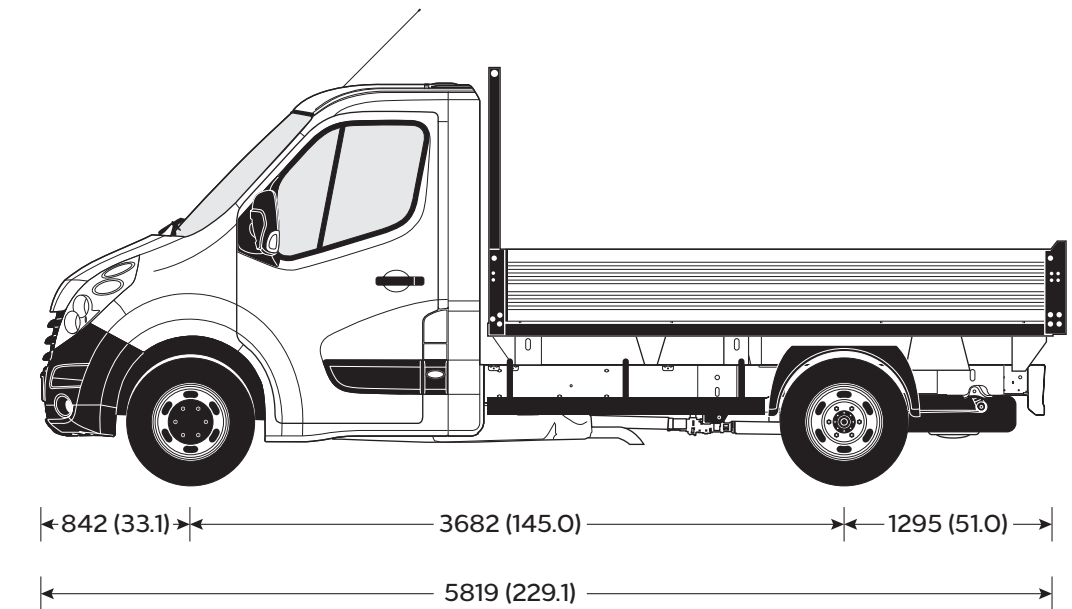
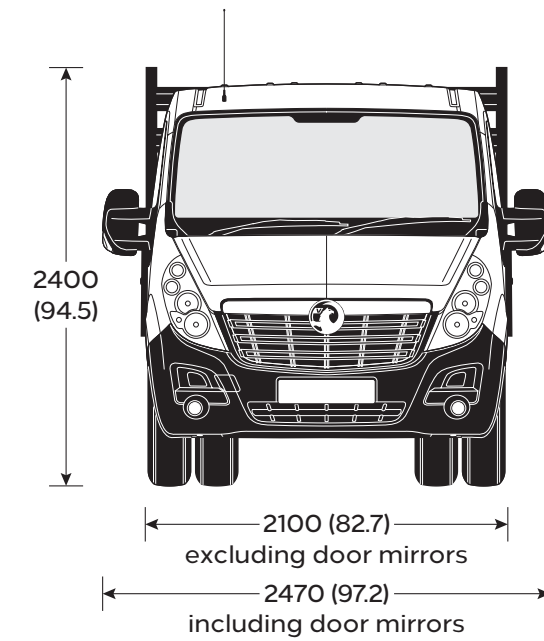

L2 RWD DRW

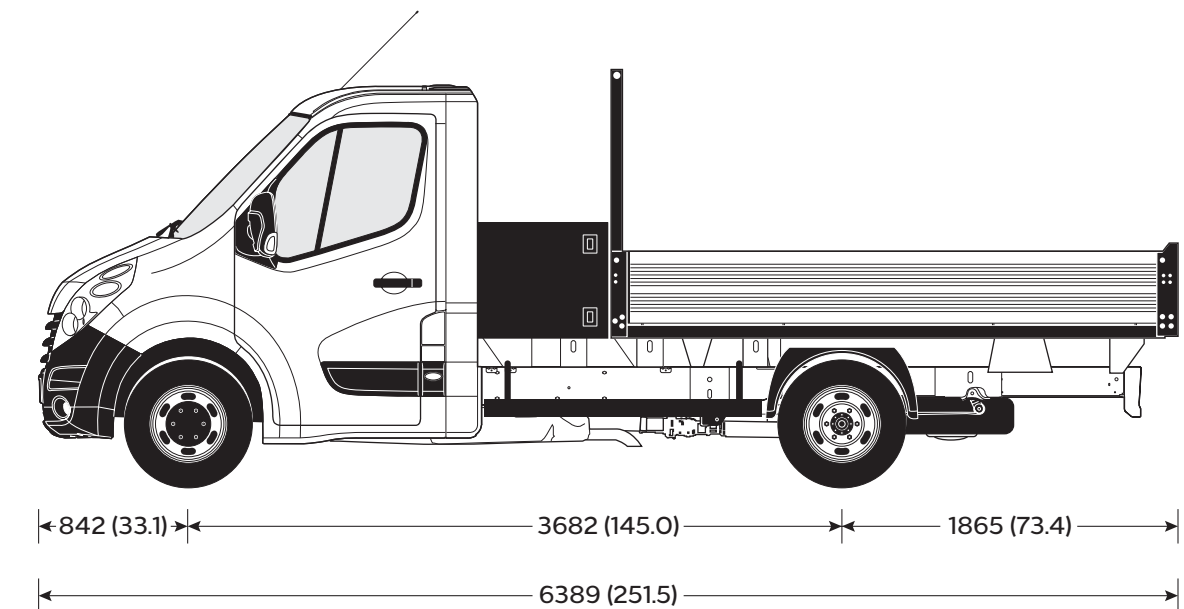
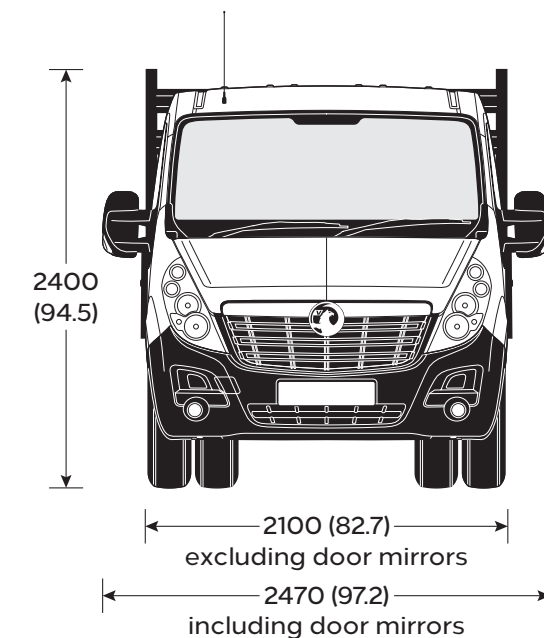

L3 RWD DRW

NEW MOVANO CREW CAB TIPPER SPECIFICATIONS

Loadspace Dimensions	L3 FWD	L3 RWD DRW
Maximum length	3205 (126.2)	3105 (122.2)
Maximum width	2040 (80.3)	2040 (80.3)
Body side height	400 (15.7)	400 (15.7)
Loading height (unladen)	1090 (42.9)	1090 (42.9)
Load area sq.m (sq.ft.)	6.5 (69.4)	6.3 (68.2)

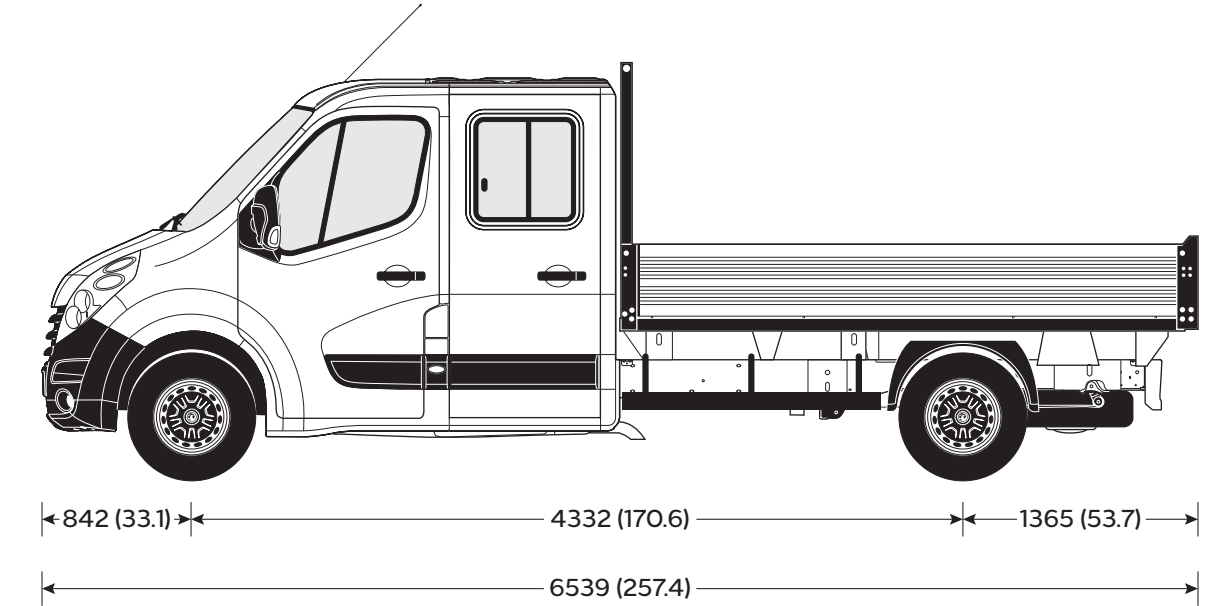
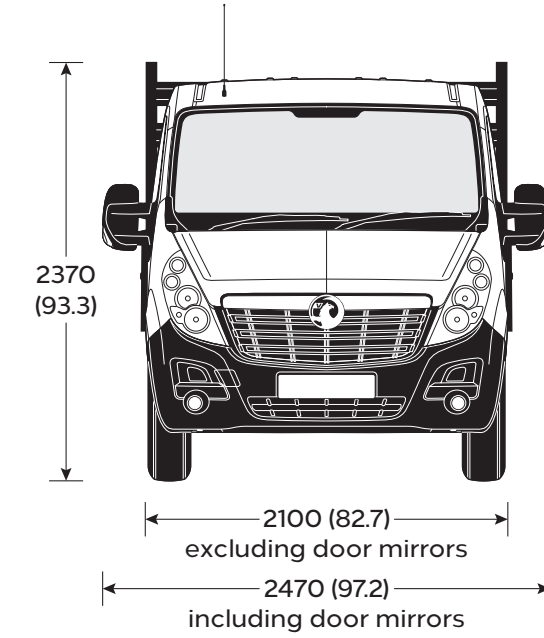

L3 FWD

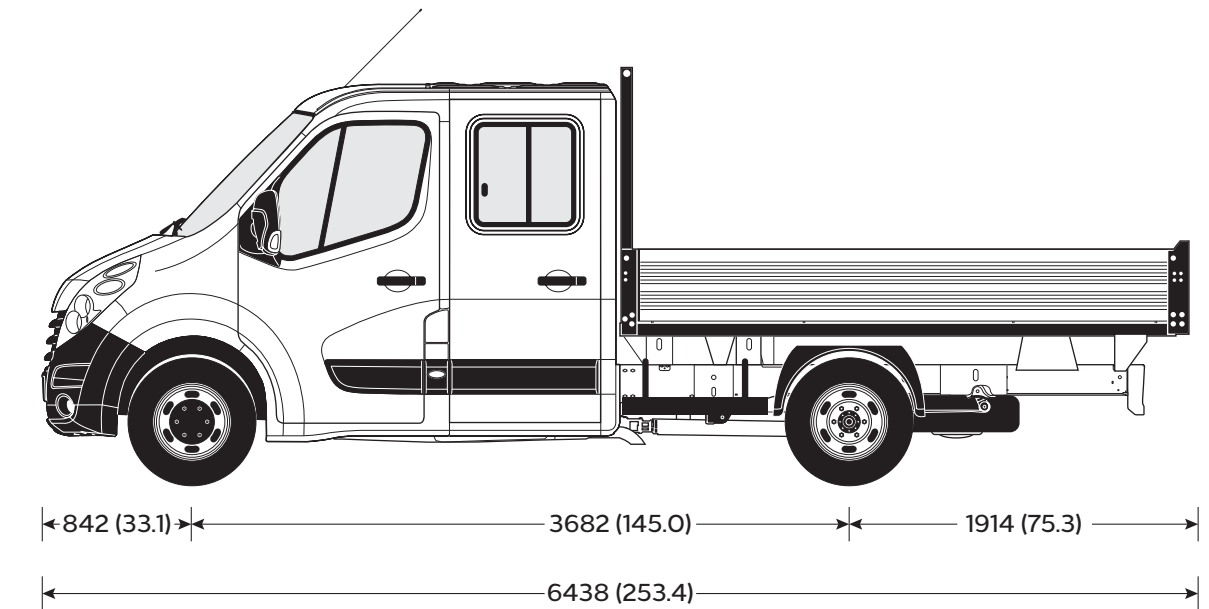
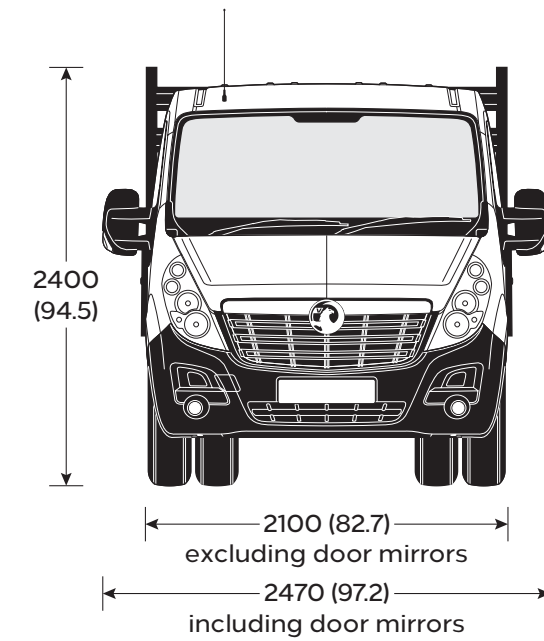

L3 RWD DRW

NEW MOVANO DROPSIDE SPECIFICATIONS

Loadspace Dimensions	L2 FWD	L2 RWD	L2 RWD DRW
Maximum length	3170 (124.8)	3170 (124.8)	3170 (124.8)
Maximum width	2040 (80.3)	2040 (80.3)	2040 (80.3)
Body side height	400 (15.7)	400 (15.7)	400 (15.7)
Loading height (unladen)	1026 (40.4)	1026 (40.4)	1026 (40.4)
Load area sq.m (sq.ft.)	6.5 (70.0)	6.5 (70.0)	6.5 (70.0)

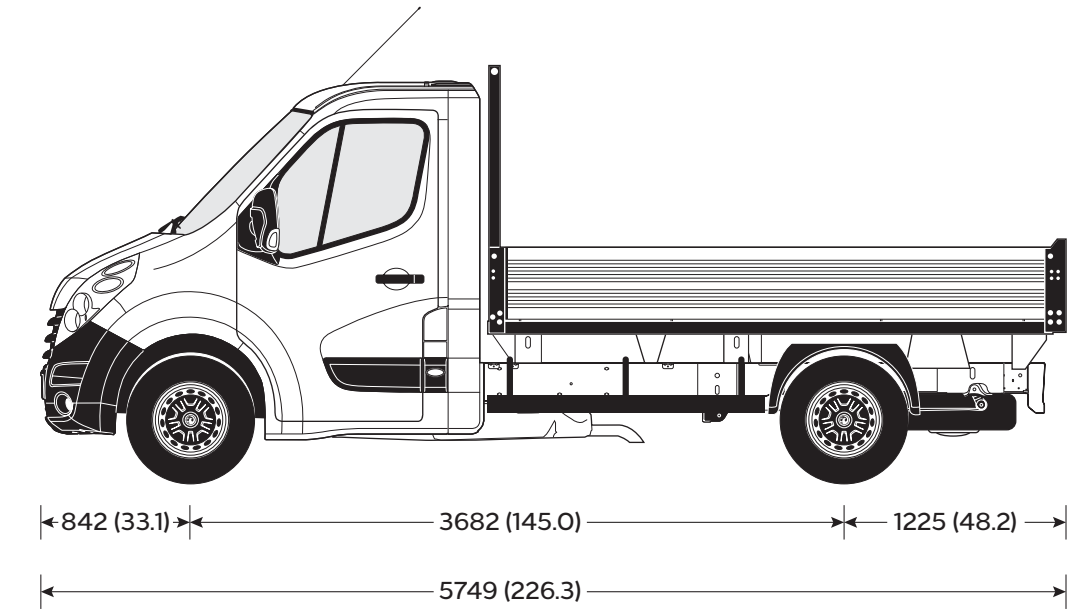
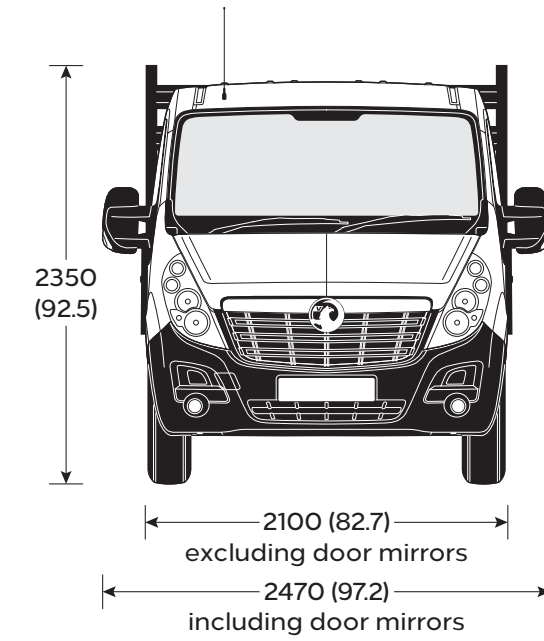

L2 FWD

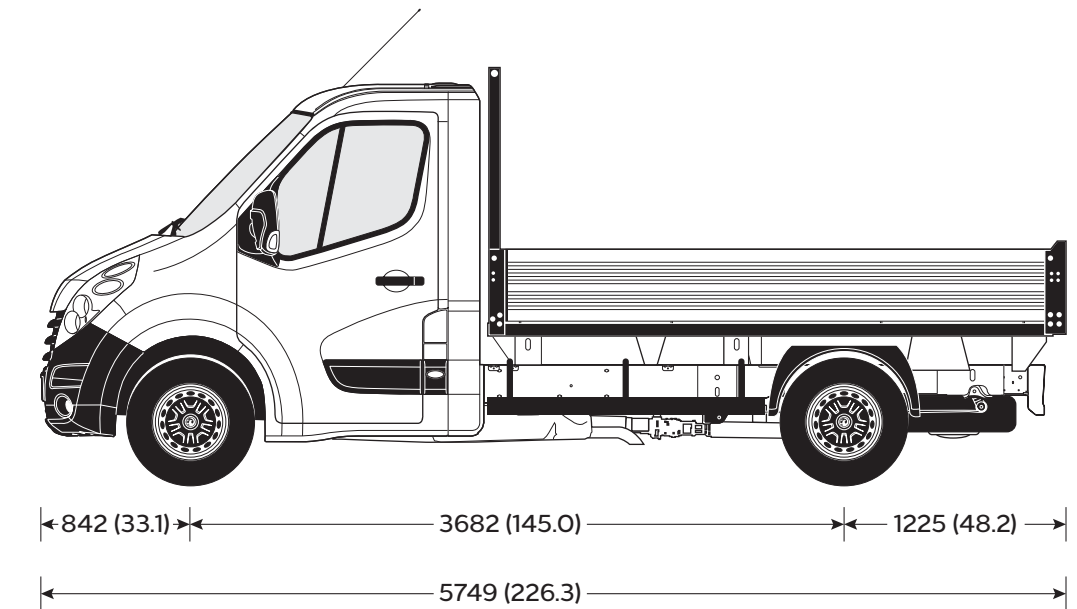
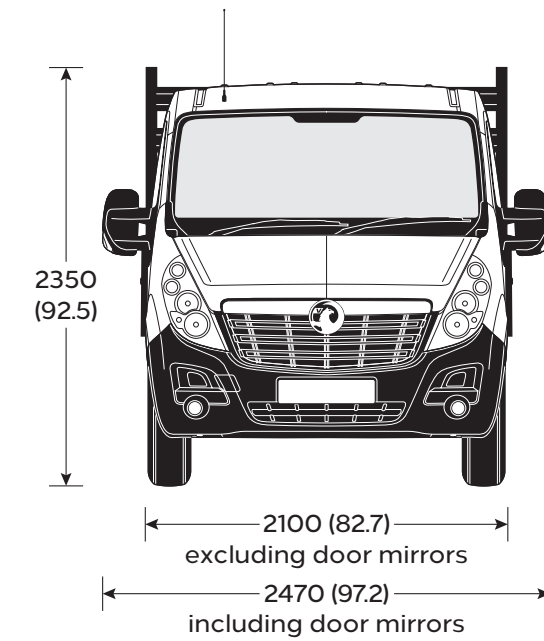

L2 RWD

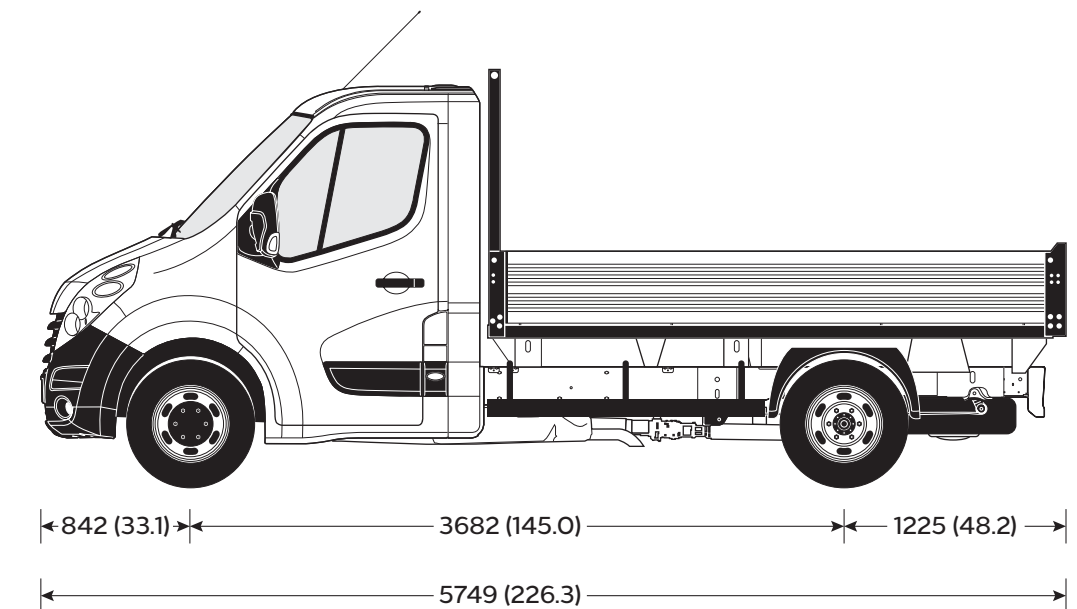
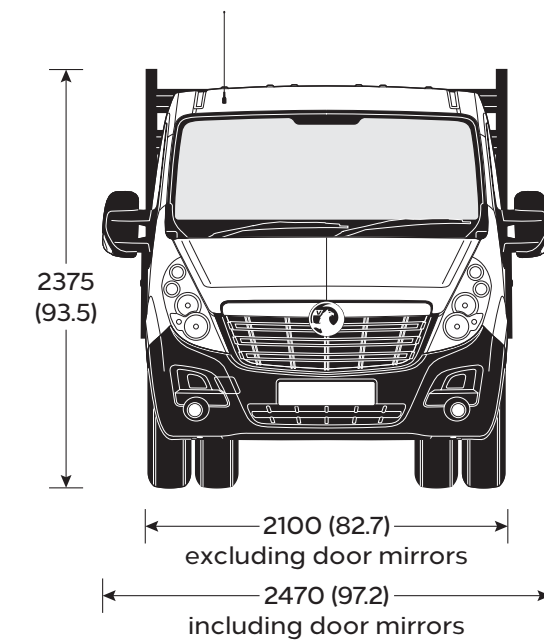

L2 RWD DRW

NEW MOVANO DROPSIDE SPECIFICATIONS

Loadspace Dimensions	L3 FWD	L3 RWD DRW	L4 RWD DRW
Maximum length	3900 (153.5)	3700 (145.7)	4470 (176.0)
Maximum width	2040 (80.3)	2040 (80.3)	2040 (80.3)
Body side height	400 (15.7)	400 (15.7)	400 (15.7)
Loading height (unladen)	1026 (40.4)	1026 (40.4)	1026 (40.4)
Load area sq.m (sq.ft.)	7.8 (83.9)	7.6 (81.8)	8.9 (95.8)

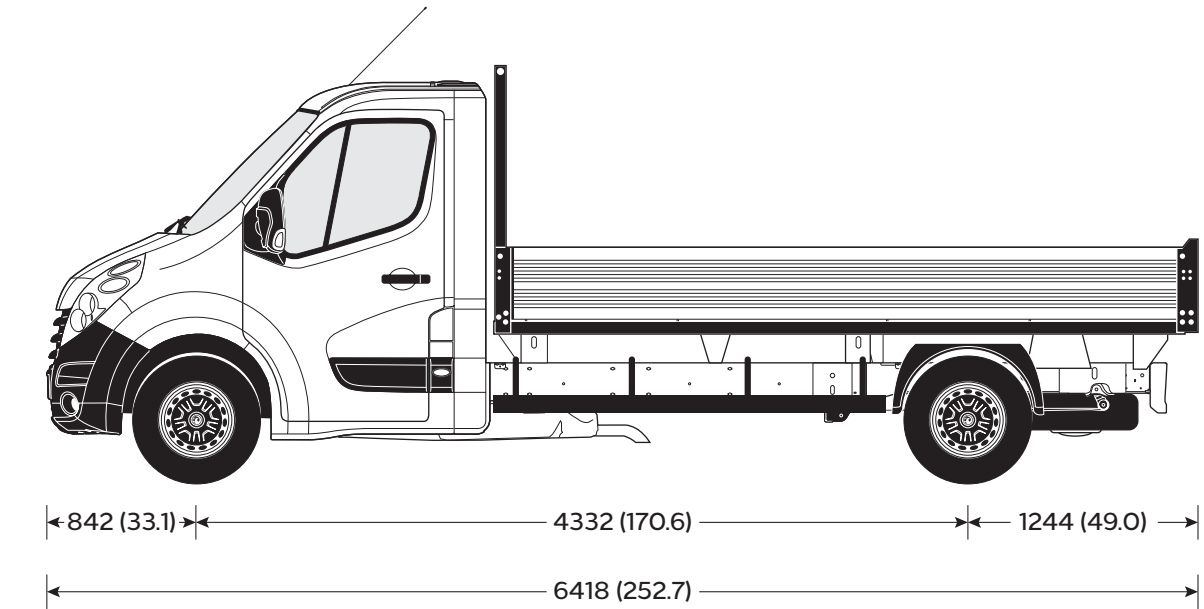
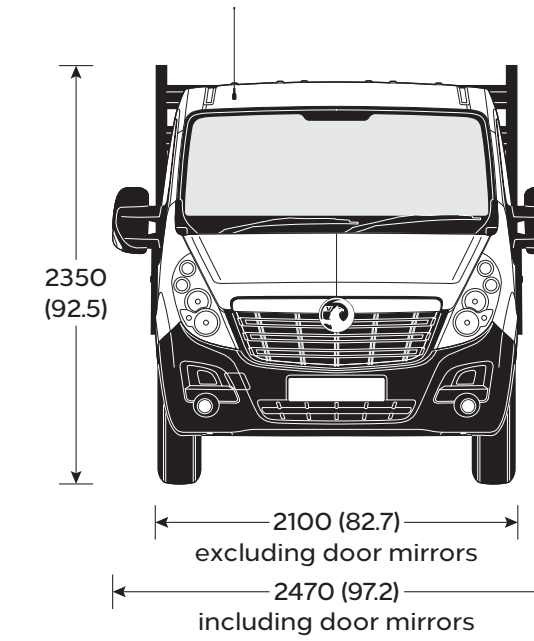

L3 FWD

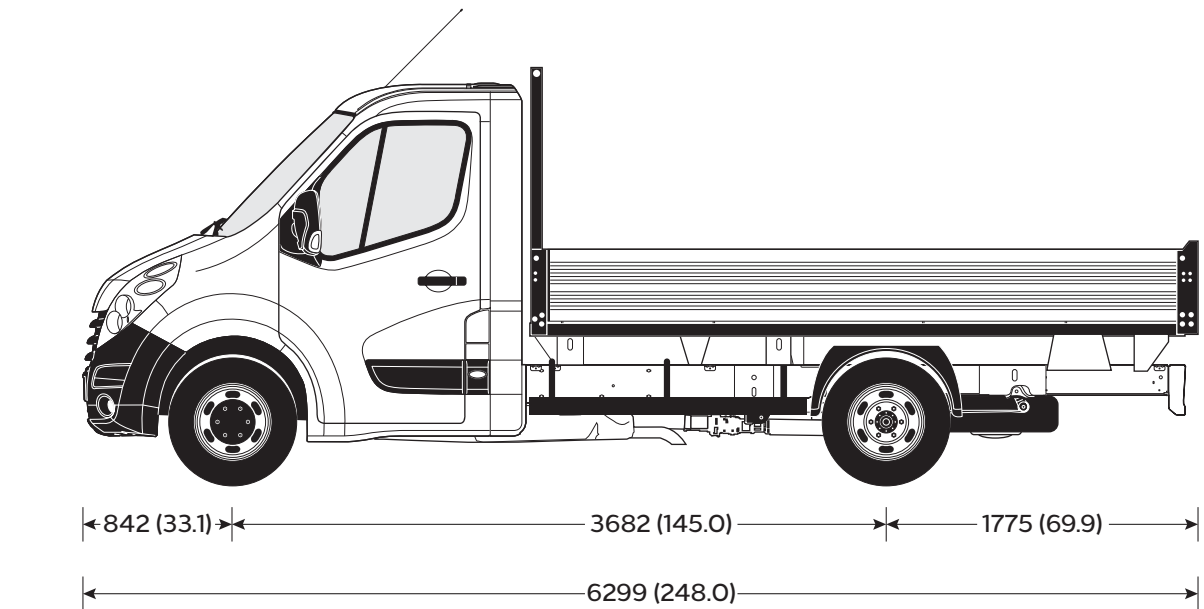
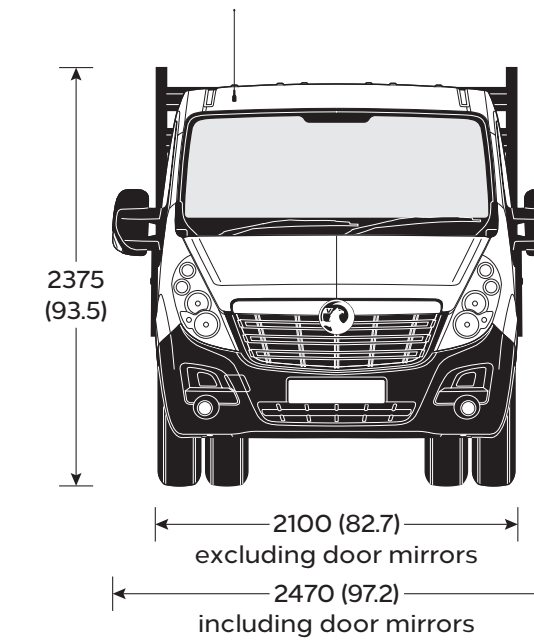

L3 RWD DRW

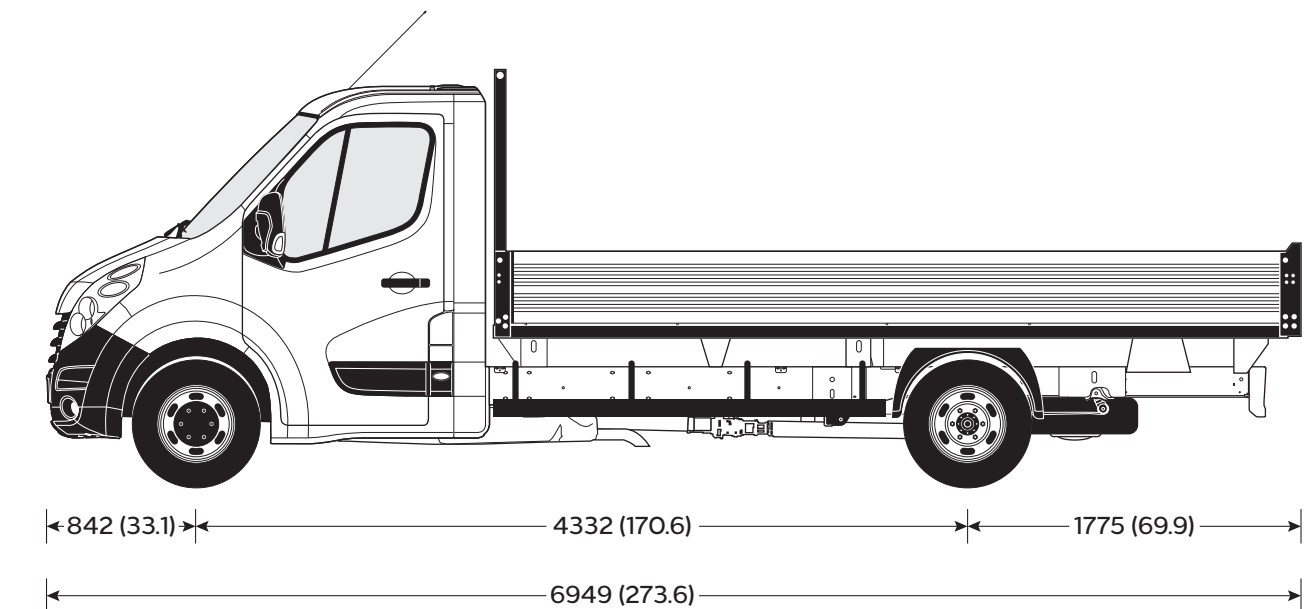
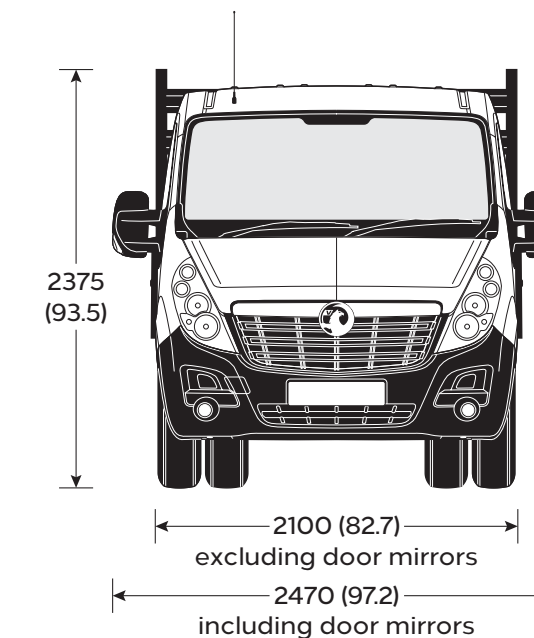

L4 RWD DRW

NEW MOVANO DROPSIDE CREW CAB SPECIFICATIONS

Loadspace Dimensions	L2 FWD	L3 FWD
Maximum length	2501 (98.5)	3170 (124.8)
Maximum width	2040 (80.3)	2040 (80.3)
Body side height	400 (15.7)	400 (15.7)
Loading height (unladen)	1026 (40.4)	1026 (40.4)
Load area sq.m (sq.ft.)	4.9 (52.7)	6.5 (70.0)

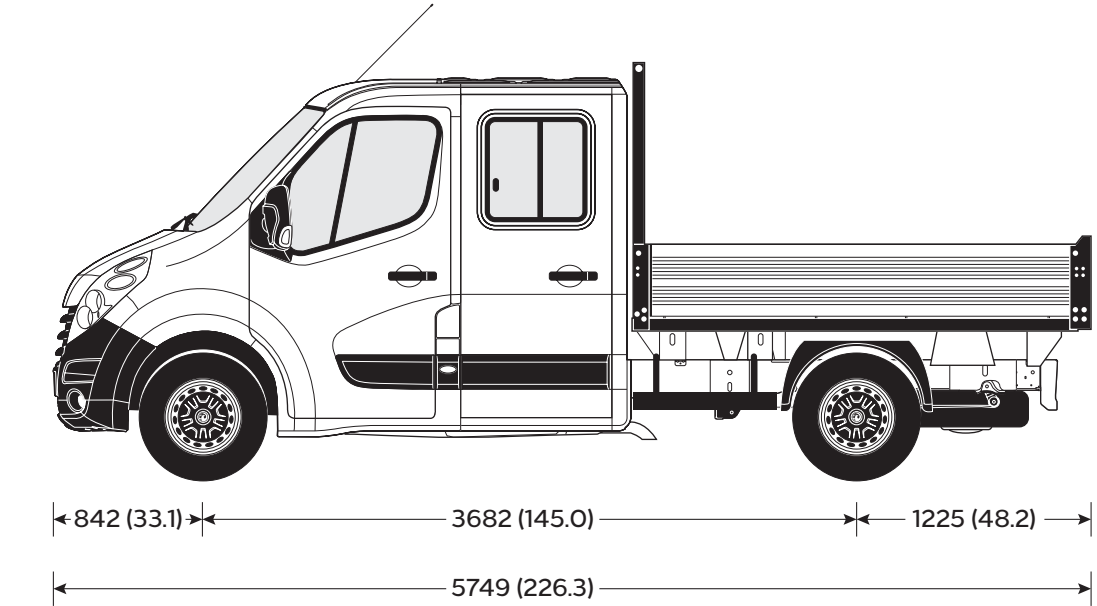
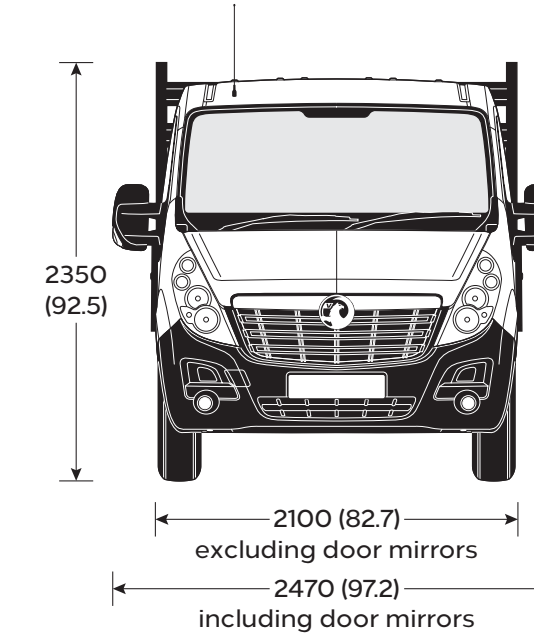

L2 FWD

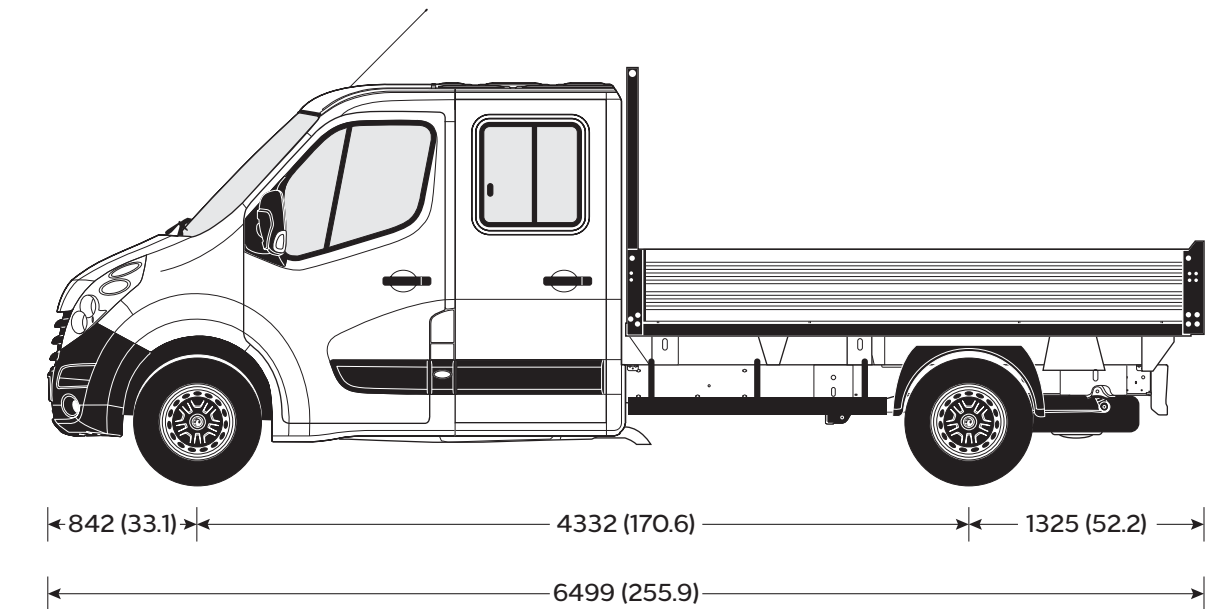
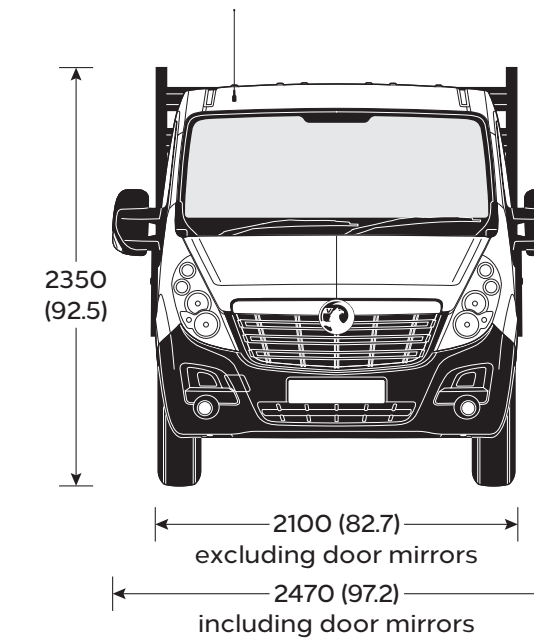

L3 FWD

NEW MOVANO DROPSIDE CREW CAB SPECIFICATIONS

Loadspace Dimensions	L2 RWD	L4 RWD DRW
Maximum length	2501 (98.5)	3702 (145.7)
Maximum width	2040 (80.3)	2040 (80.3)
Body side height	400 (15.7)	400 (15.7)
Loading height (unladen)	1026 (40.4)	1026 (40.4)
Load area sq.m (sq.ft.)	4.9 (52.7)	7.6 (81.8)

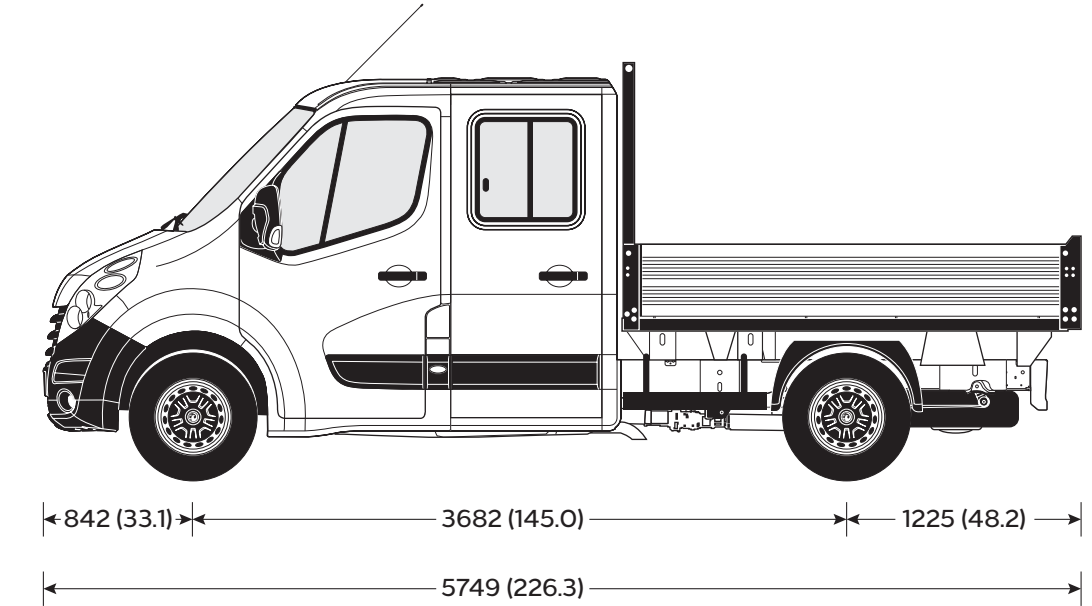
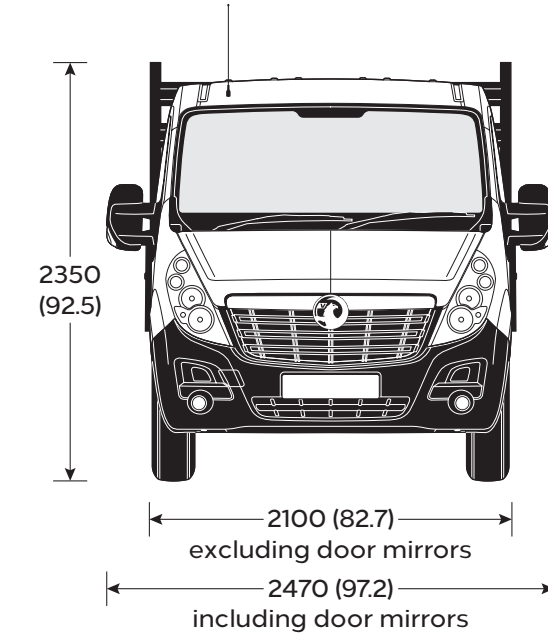

L2 RWD

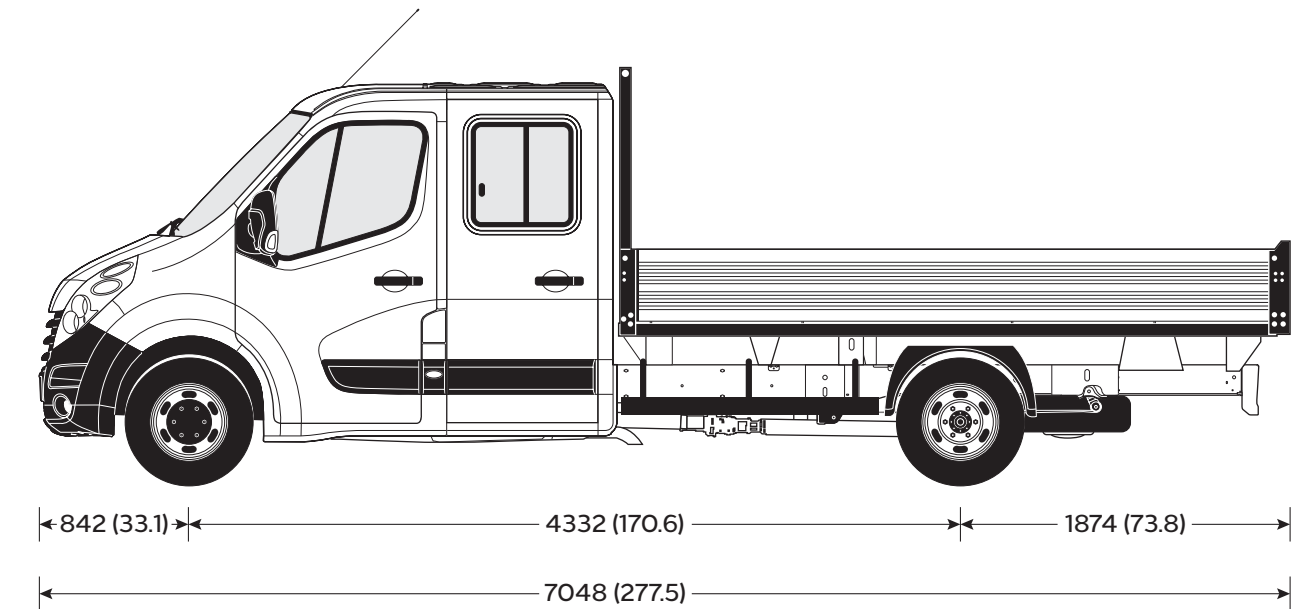
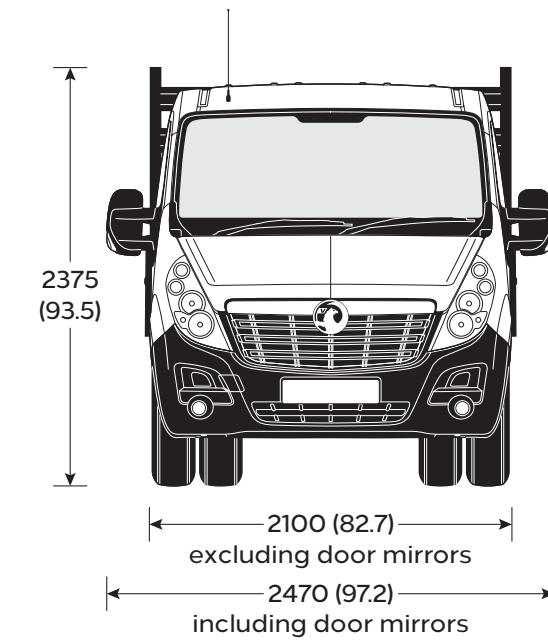

L4 RWD DRW

NEW MOVANO BOX VAN SPECIFICATIONS

Loadspace Dimensions	L3 20cu.m FWD
Maximum internal length	4100 (161.4)
Maximum internal width	2150 (84.6)
Maximum internal height	2200 (86.6)
Loading height (unladen)	1050 (41.3)
Loadspace Volumes cu.m (cu.ft.)	
VDA method	19.4 (685.1)

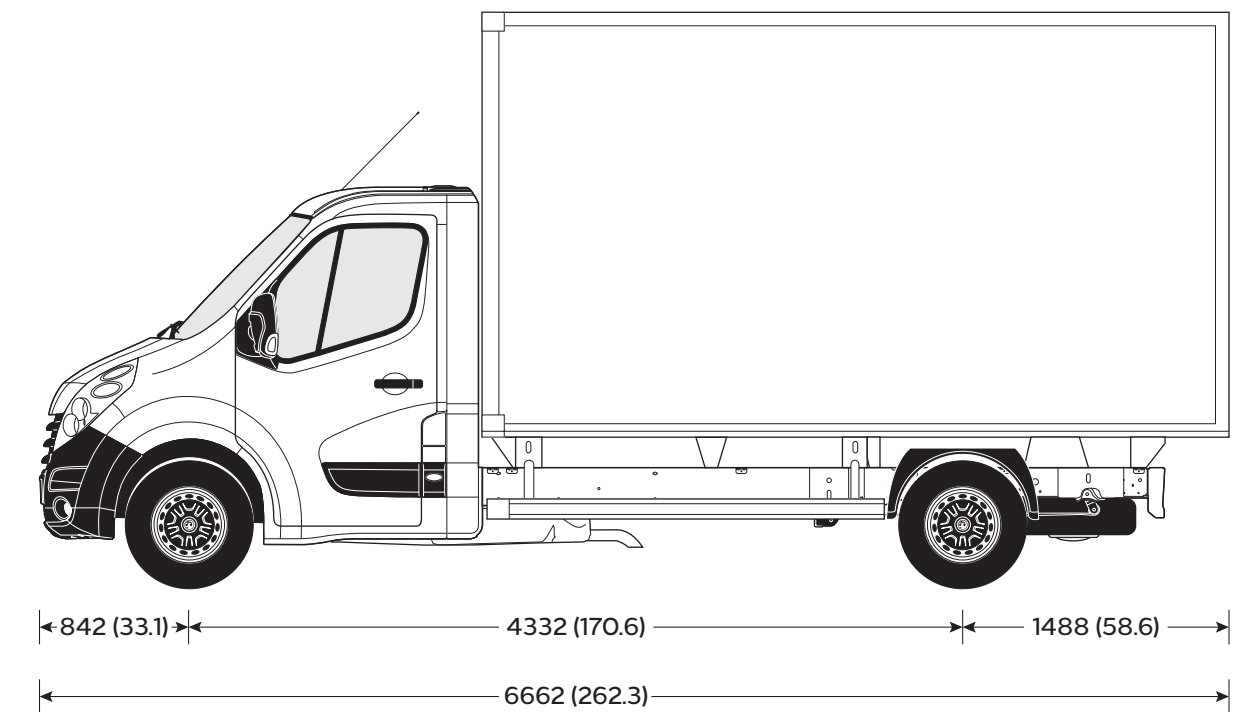
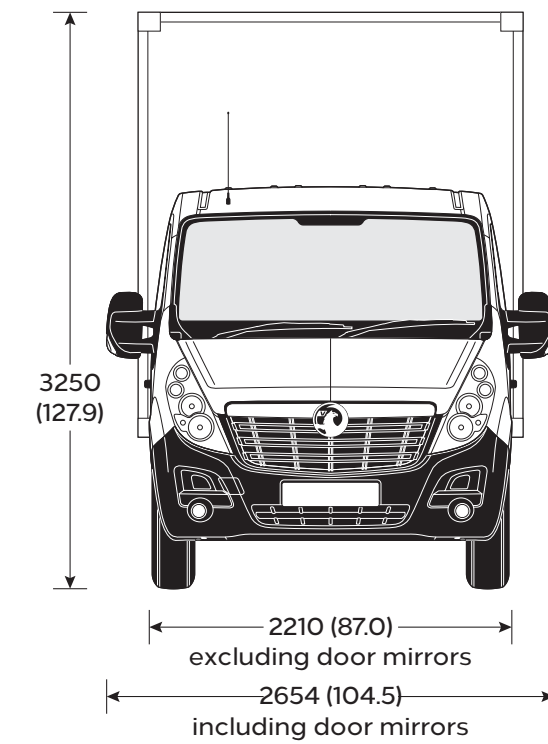

L3 FWD (20cu.m)

NEW MOVANO CHASSIS CAB SPECIFICATIONS

New Movano chassis cab models feature rugged box section chassis rails, featuring wide top sections with built-in mounting points. The bolted rear under-run bar on 4.5T variants provides additional in-built safety, as well as ample margins for additional bodywork while retaining outstanding payloads.

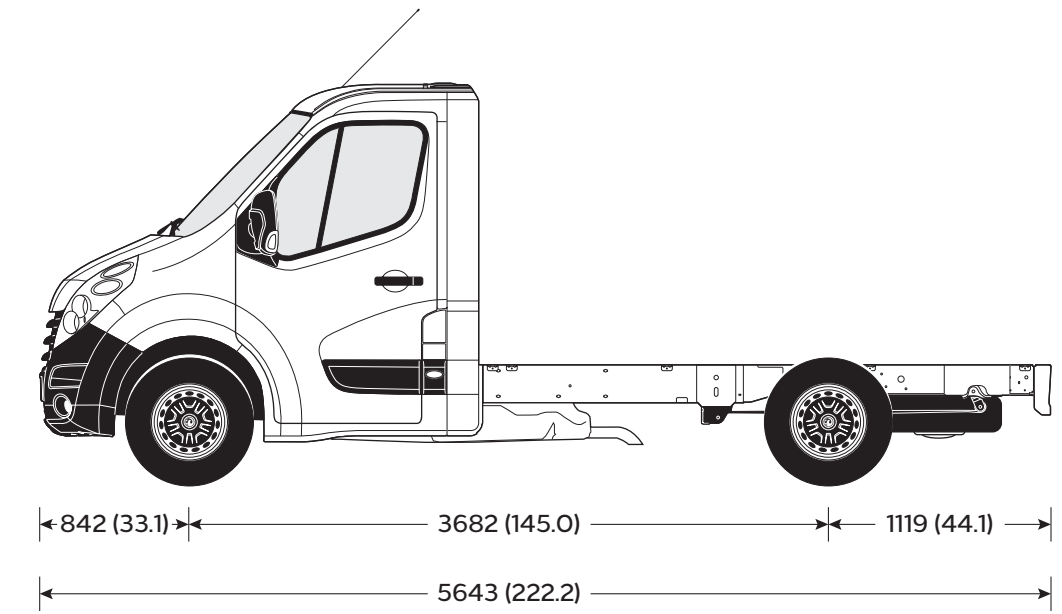
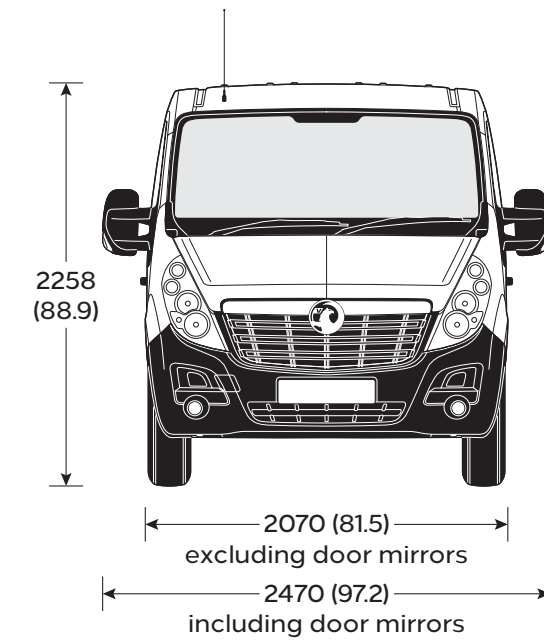

L2 FWD

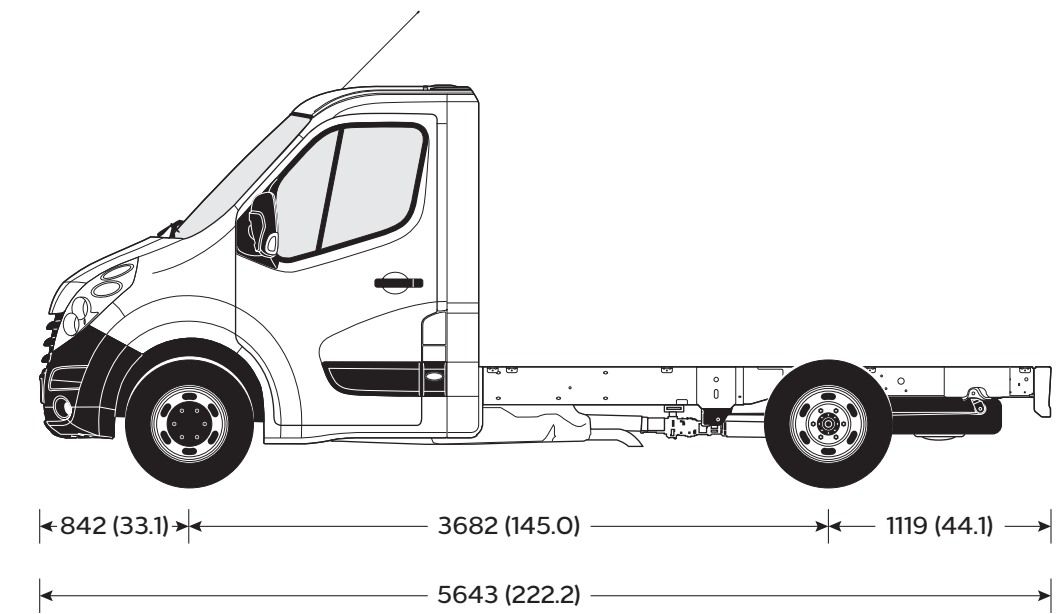
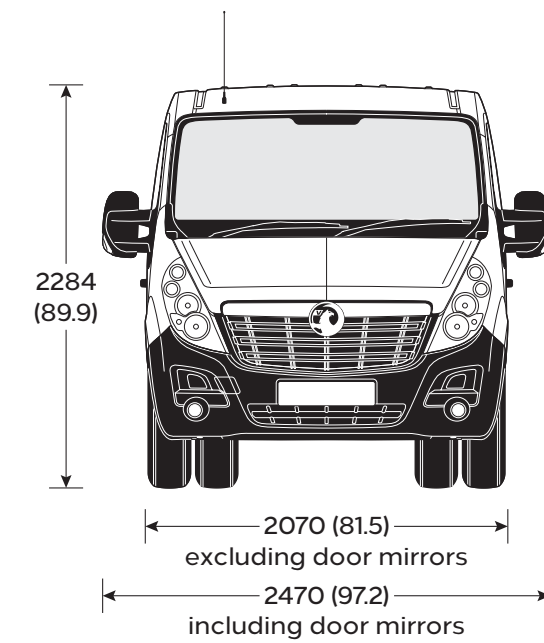

L2 RWD/L2 RWD DRW

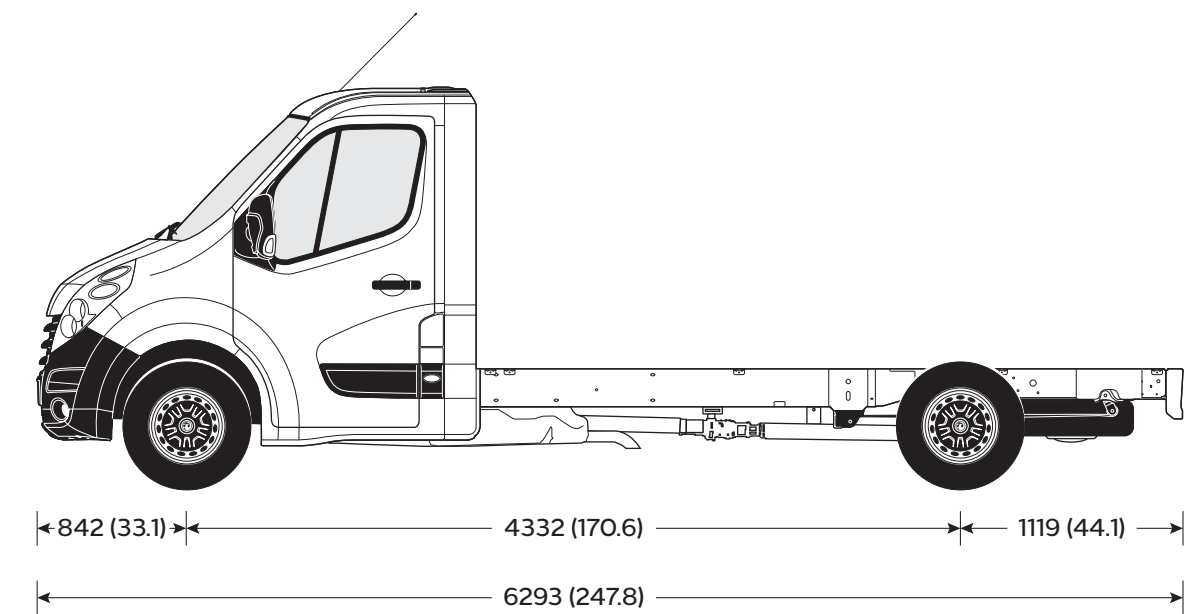
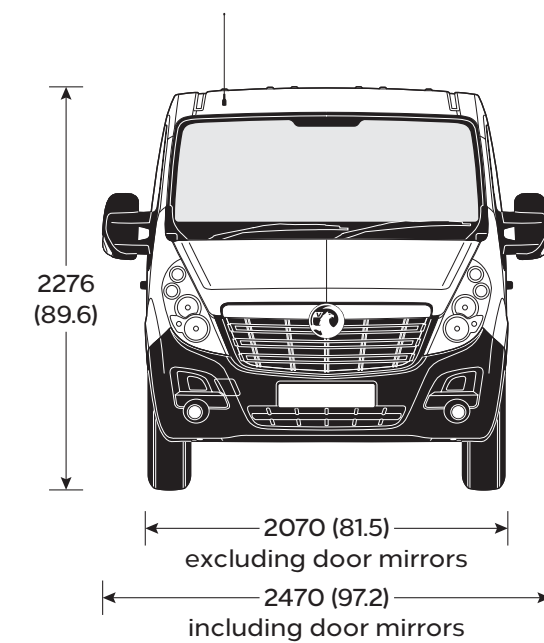

L3 RWD

All conversions must follow 'Vauxhall Converter Requirements' including recommended dimensional data, detailed within Part 1, available at: www.converters-and-groupe-psa.com. The weight of any fitted conversion body will have to be deducted from these figures to establish actual payload and is subject to correct weight distribution. Variations from the recommended dimensions or weights may affect the vehicle's overall centre of gravity and stability. From 29 April 2013 conversion of N1 vehicles was affected by changes to type approval – for further information refer to the VCA website (N2 vehicles were affected from 29 October 2014). For further information please contact conversions@vauxhall.co.uk

All measurements are in mm (inches) unless stated otherwise. Heights shown unladen.

NEW MOVANO CHASSIS CAB SPECIFICATIONS

New Movano chassis cab models feature rugged box section chassis rails, featuring wide top sections with built-in mounting points. The bolted rear under-run bar on 4.5T variants provides additional in-built safety, as well as ample margins for additional bodywork while retaining outstanding payloads.

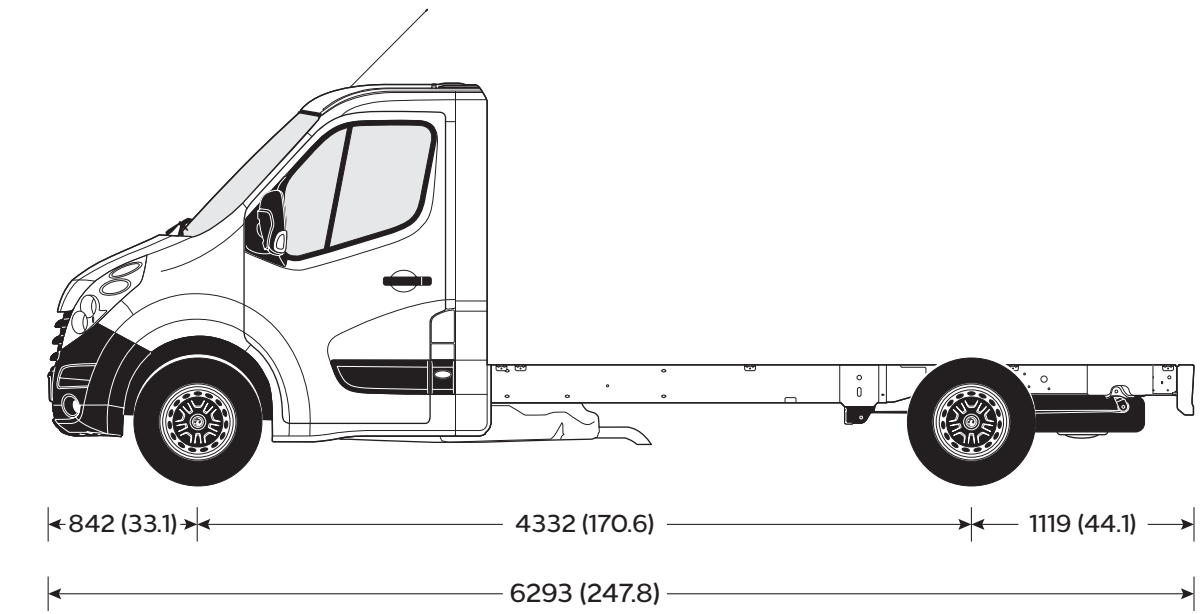
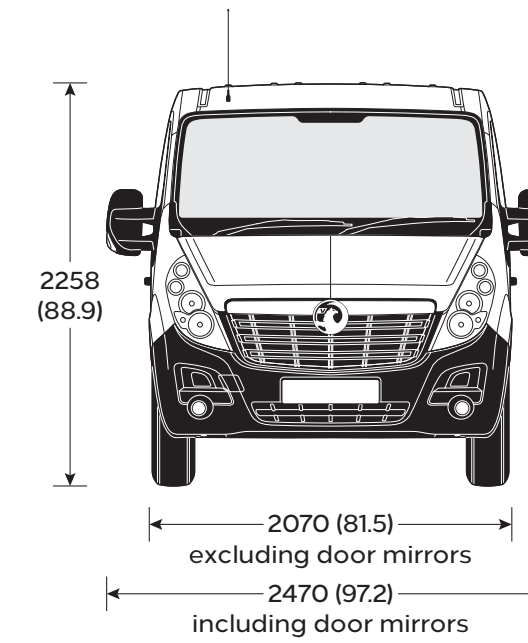

L3 FWD

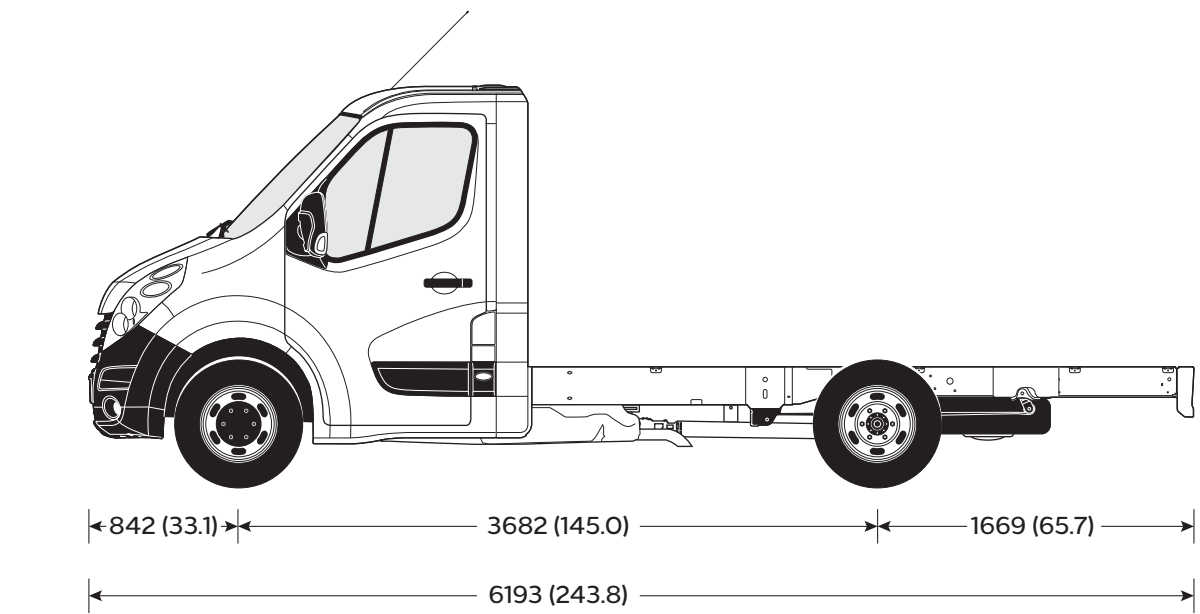
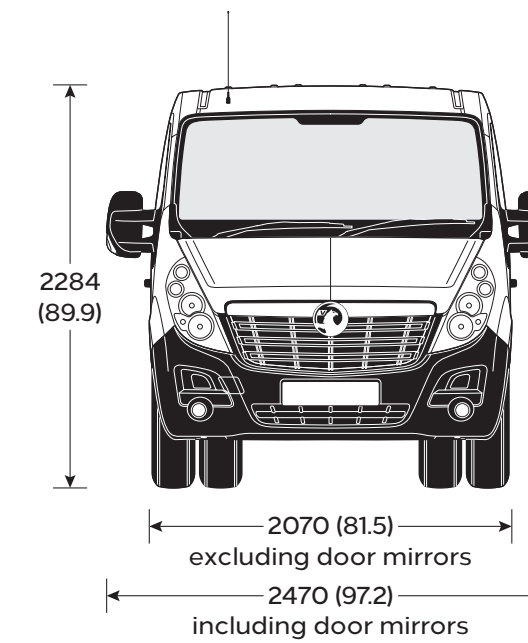

L3 RWD DRW

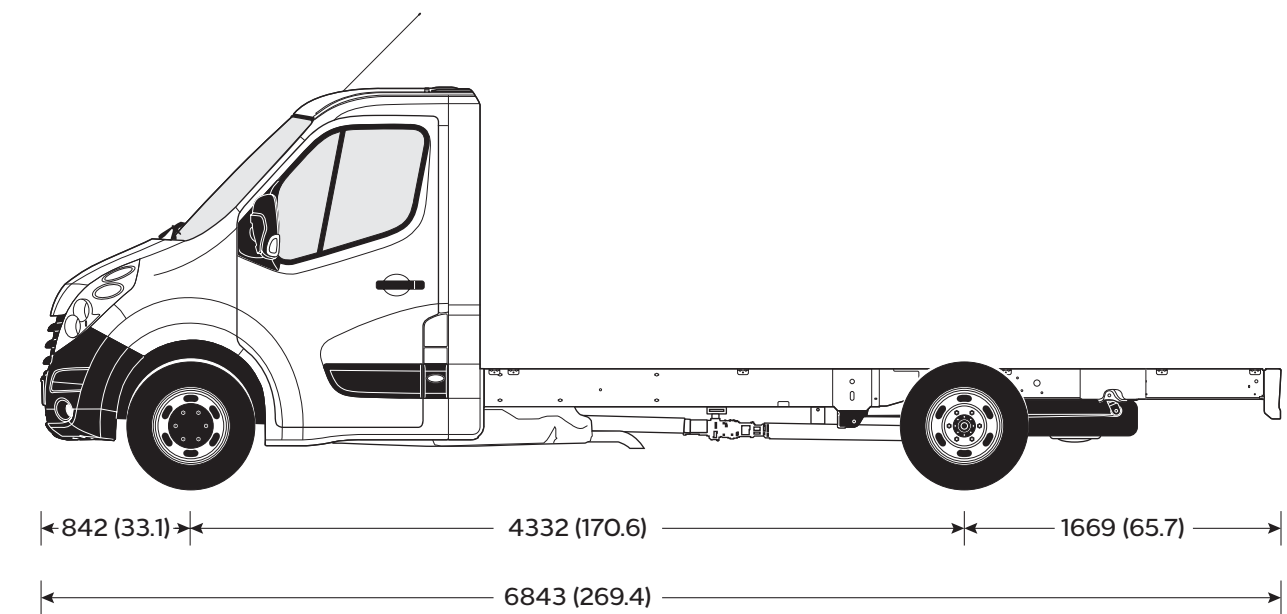
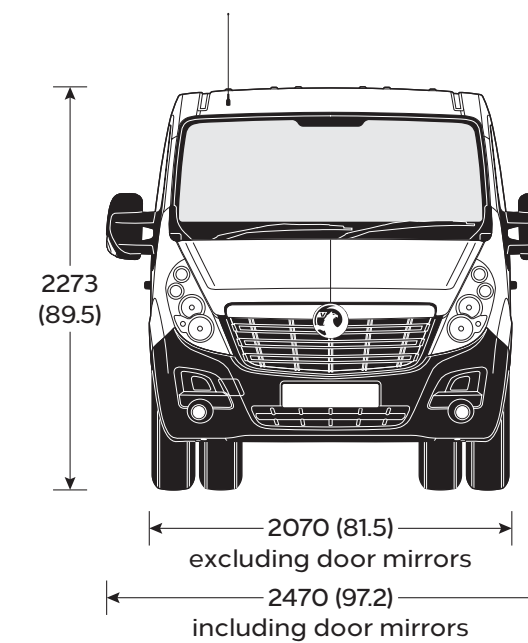

L4 RWD DRW

All conversions must follow 'Vauxhall Converter Requirements' including recommended dimensional data, detailed within Part 1, available at: www.converters-and-groupe-psa.com. The weight of any fitted conversion body will have to be deducted from these figures to establish actual payload and is subject to correct weight distribution. Variations from the recommended dimensions or weights may affect the vehicle's overall centre of gravity and stability. From 29 April 2013 conversion of N1 vehicles was affected by changes to type approval – for further information refer to the VCA website (N2 vehicles were affected from 29 October 2014). For further information please contact conversions@vauxhall.co.uk

All measurements are in mm (inches) unless stated otherwise. Heights shown unladen.

NEW MOVANO CHASSIS CREW CAB SPECIFICATIONS

Crew cab models provide the same choice of body configurations and GVWs as our chassis cab variants but introduce an added dose of versatility by providing extra accommodation for four additional crew members.

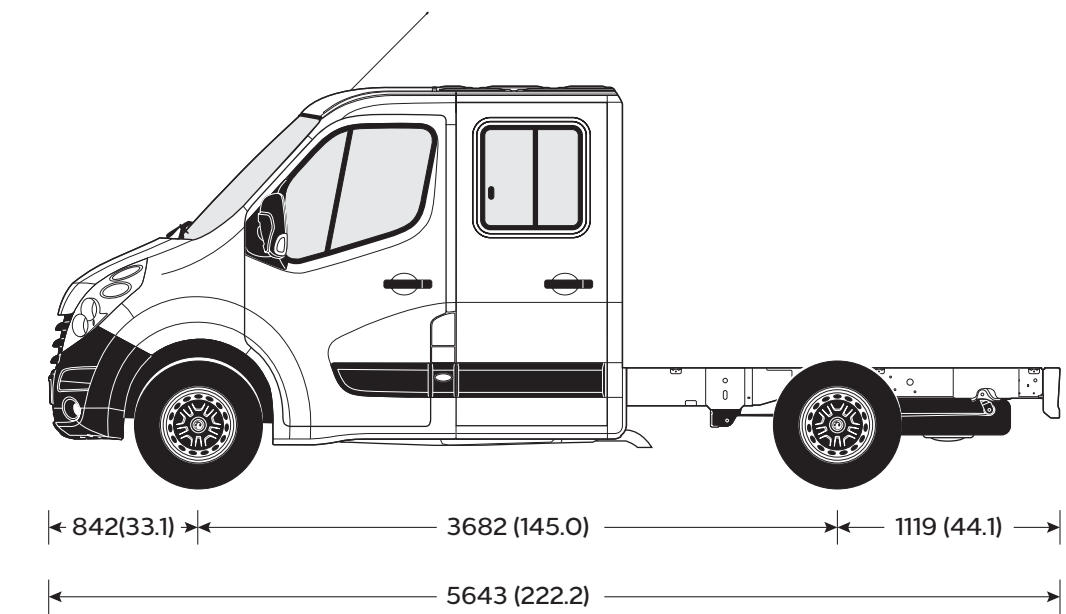
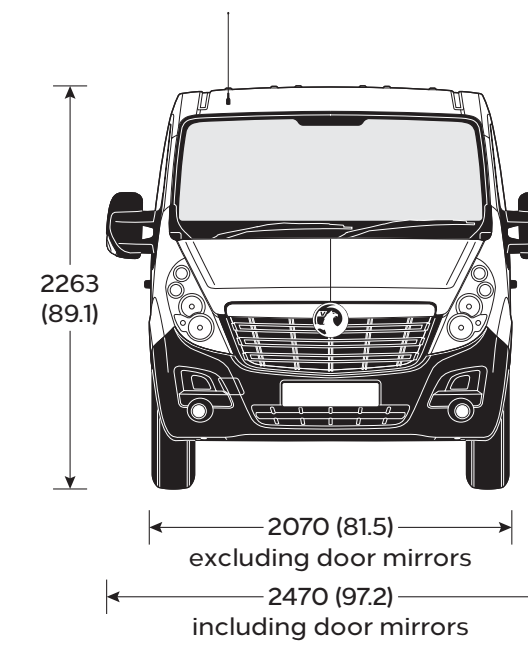

L2 FWD

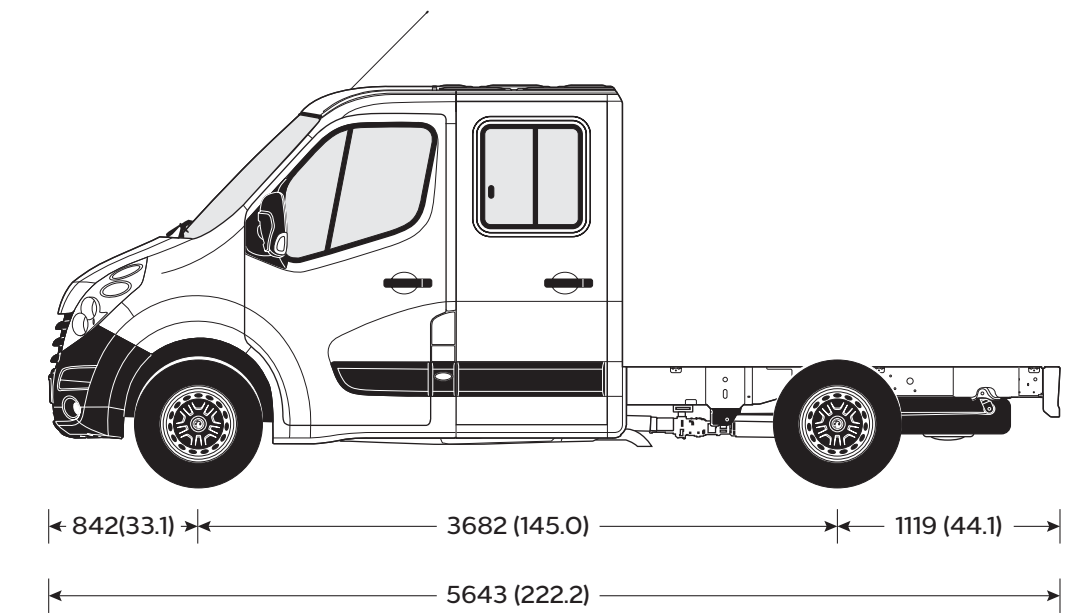
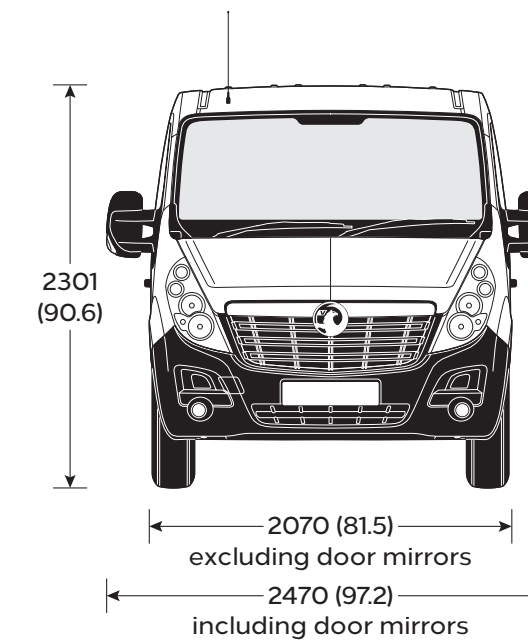

L2 RWD

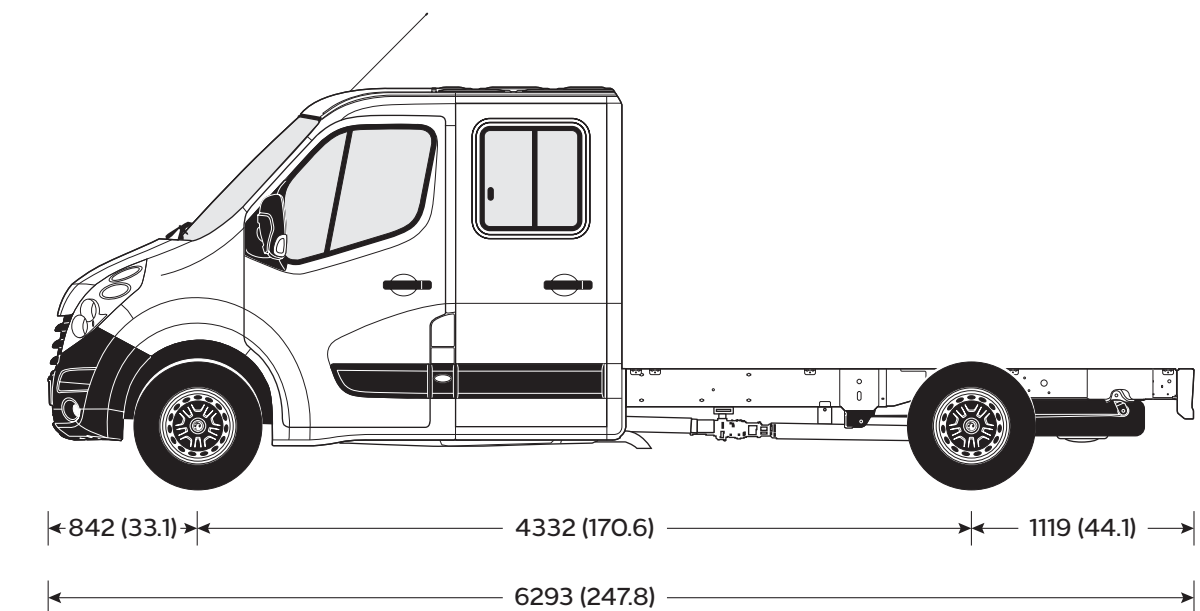
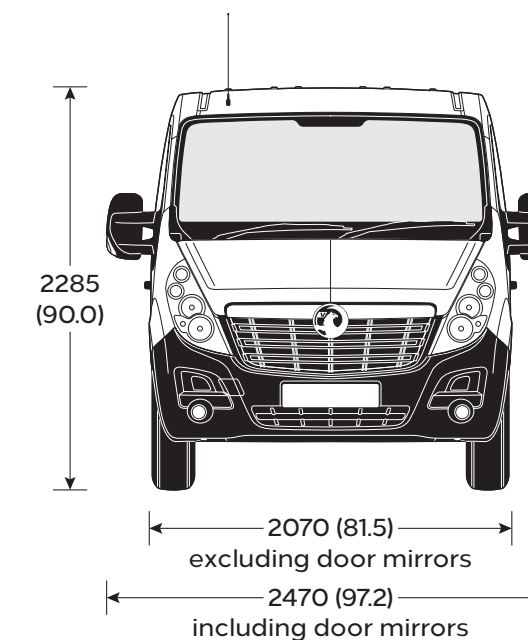

L3 RWD

All conversions must follow 'Vauxhall Converter Requirements' including recommended dimensional data, detailed within Part 1, available at: www.converters-and-groupe-psa.com. The weight of any fitted conversion body will have to be deducted from these figures to establish actual payload and is subject to correct weight distribution. Variations from the recommended dimensions or weights may affect the vehicle's overall centre of gravity and stability. From 29 April 2013 conversion of N1 vehicles was affected by changes to type approval – for further information refer to the VCA website (N2 vehicles were affected from 29 October 2014). For further information please contact conversions@vauxhall.co.uk

All measurements are in mm (inches) unless stated otherwise. Heights shown unladen.

NEW MOVANO CHASSIS CREW CAB SPECIFICATIONS

Crew cab models provide the same choice of body configurations and GVWs as our chassis cab variants but introduce an added dose of versatility by providing extra accommodation for four additional crew members.

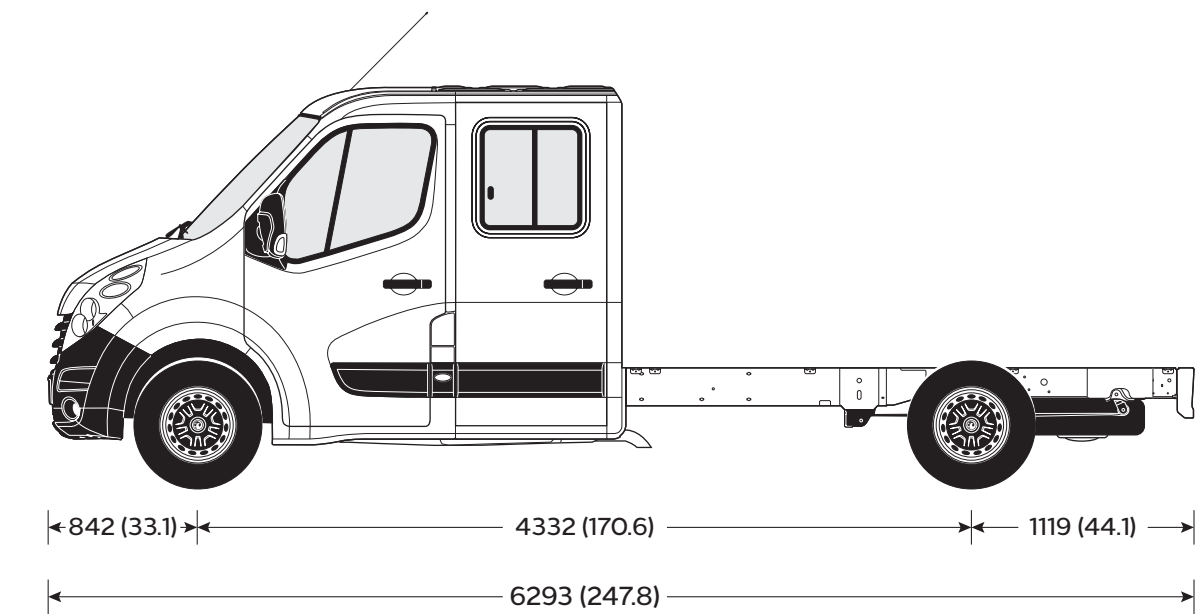
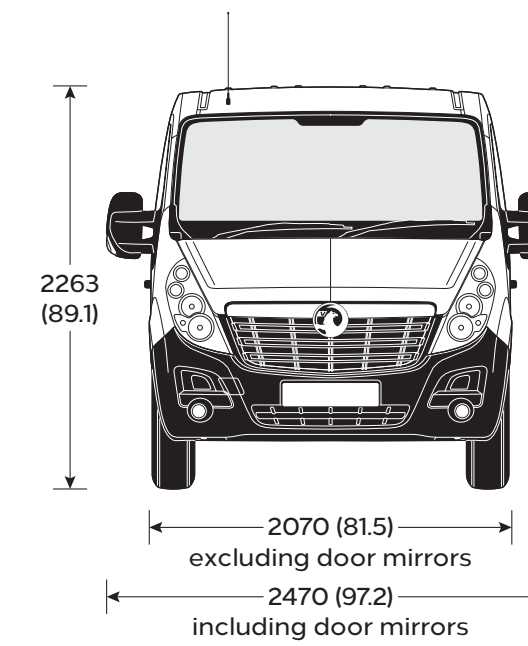

L3 FWD

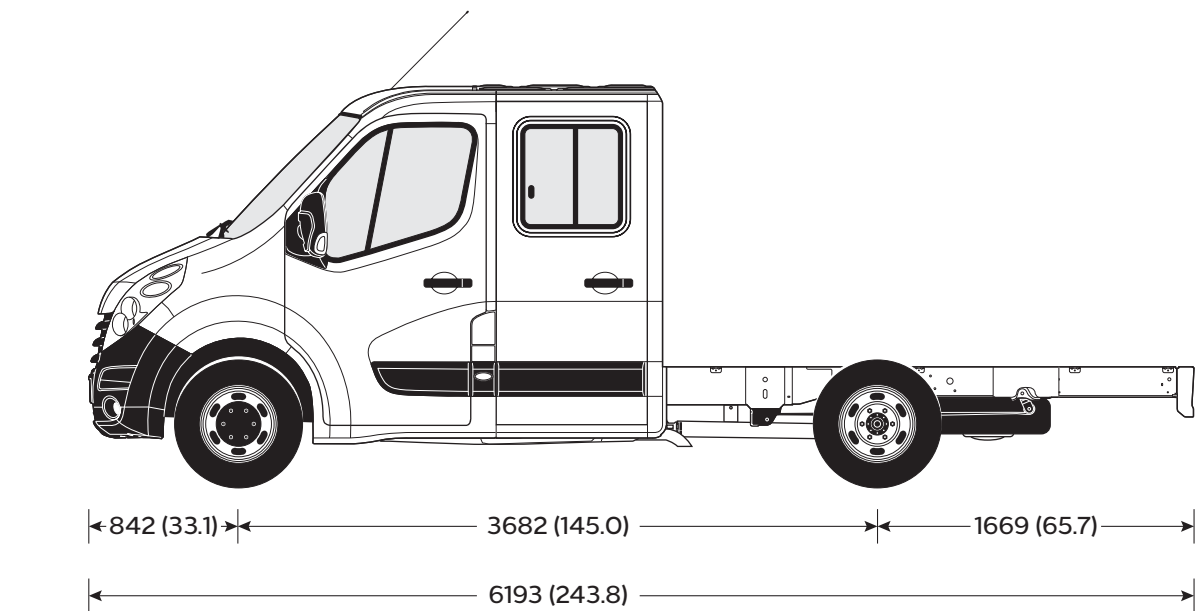
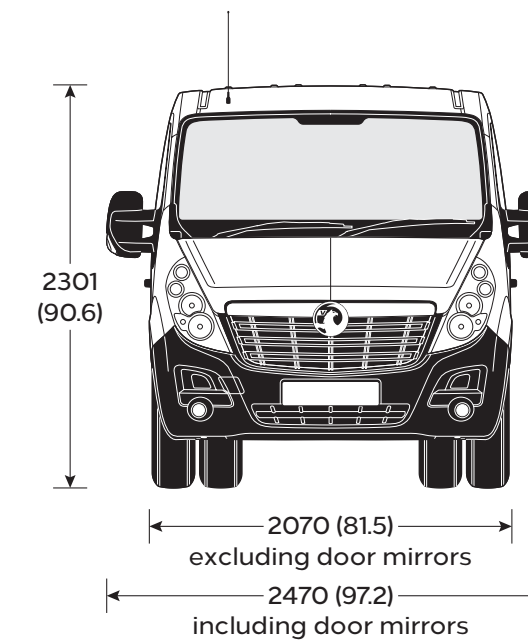

L3 RWD DRW

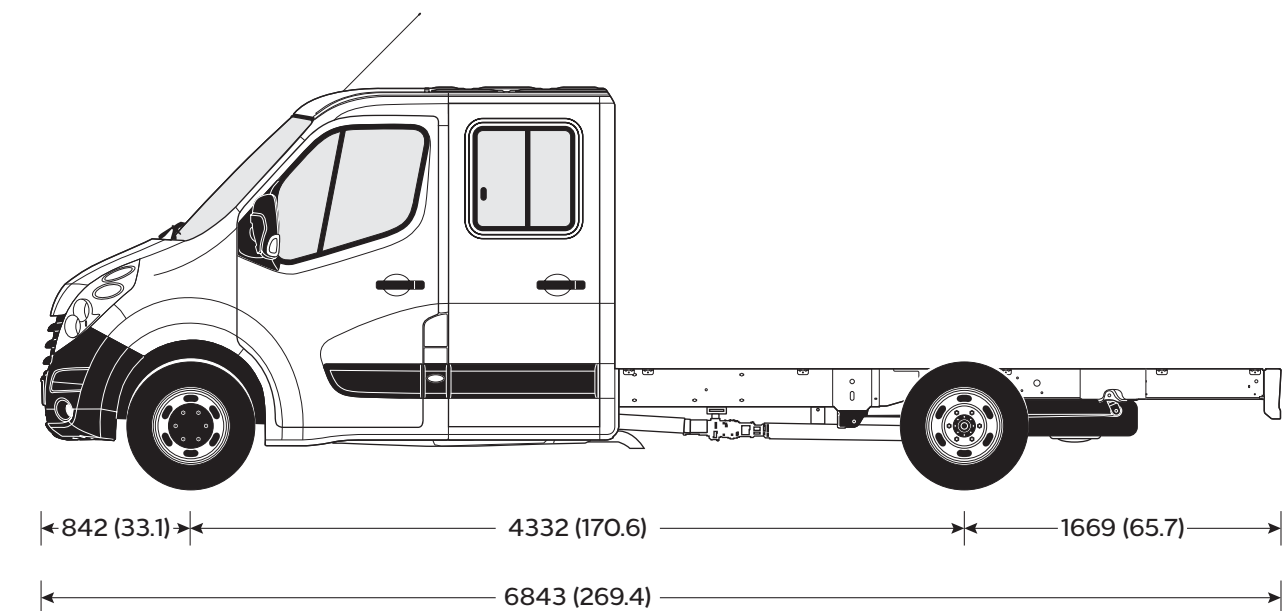
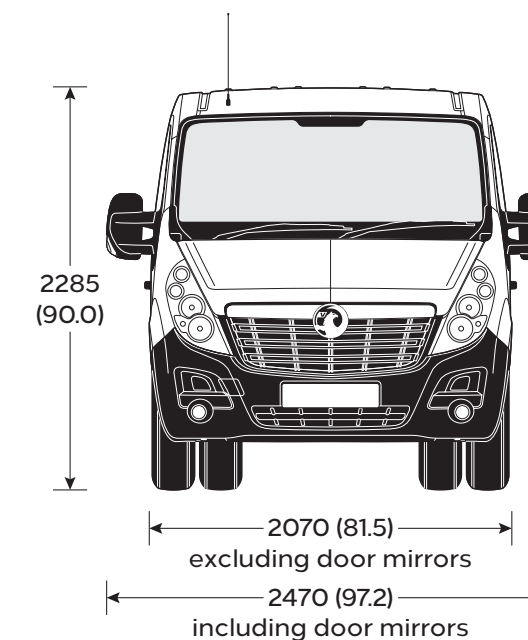

L4 RWD DRW

All conversions must follow 'Vauxhall Converter Requirements' including recommended dimensional data, detailed within Part 1, available at: www.converters-and-groupe-psa.com. The weight of any fitted conversion body will have to be deducted from these figures to establish actual payload and is subject to correct weight distribution. Variations from the recommended dimensions or weights may affect the vehicle's overall centre of gravity and stability. From 29 April 2013 conversion of N1 vehicles was affected by changes to type approval – for further information refer to the VCA website (N2 vehicles were affected from 29 October 2014). For further information please contact conversions@vauxhall.co.uk

All measurements are in mm (inches) unless stated otherwise. Heights shown unladen.

NEW MOVANO PLATFORM CAB SPECIFICATIONS

Platform cabs are ideal for those conversions requiring a low floor and walk-through access from the cab. The interface panel makes for easy integration of the cab with the conversion body, while an extended-length wiring loom is available to power the rear lights or extended conversions.

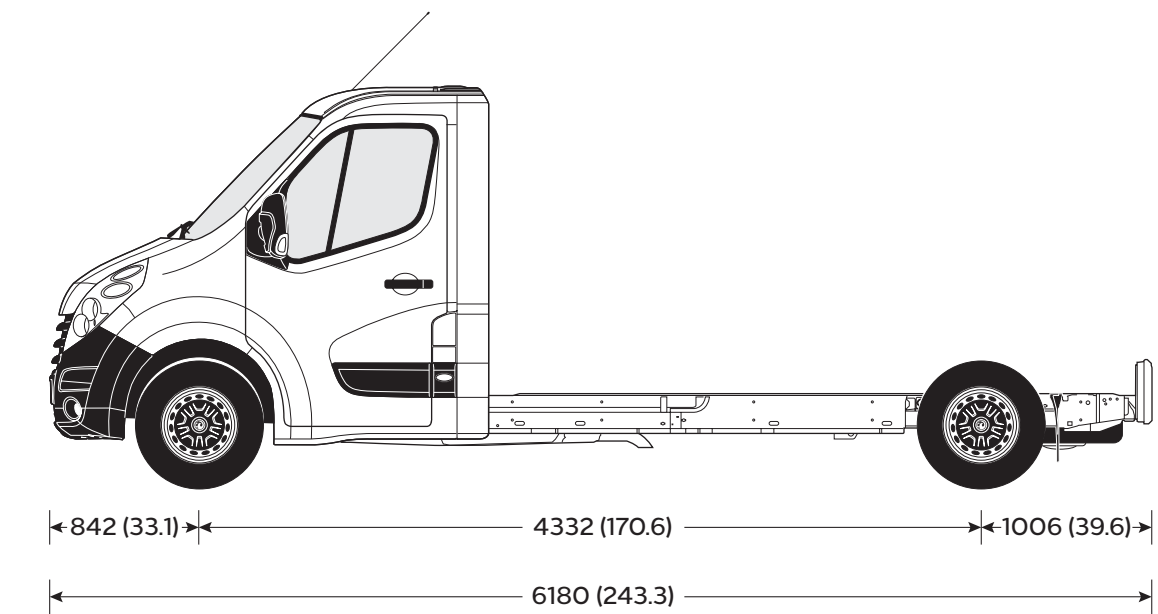
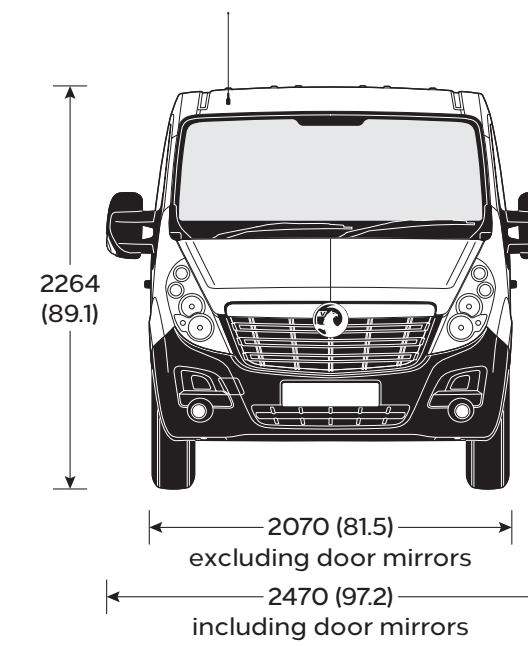

L3 H1 FWD

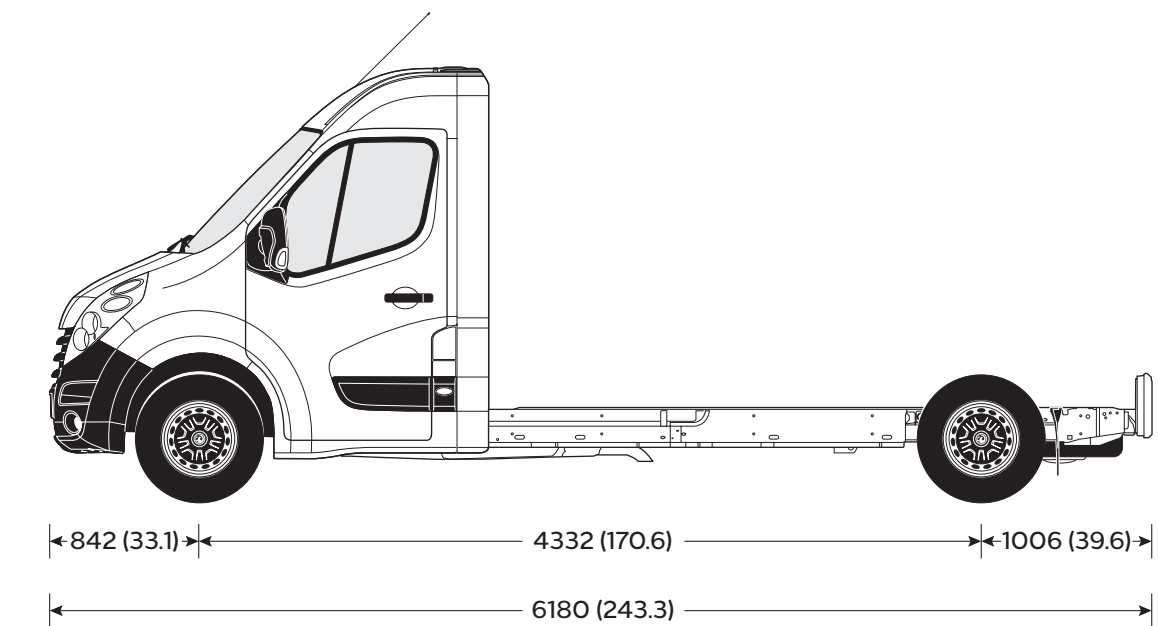
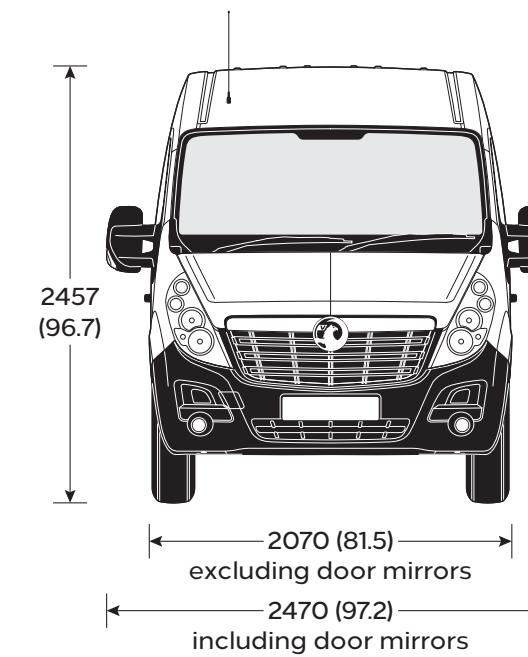

L3 H2 FWD

All conversions must follow 'Vauxhall Converter Requirements' including recommended dimensional data, detailed within Part 1, available at: www.converters-and-groupe-psa.com. The weight of any fitted conversion body will have to be deducted from these figures to establish actual payload and is subject to correct weight distribution. Variations from the recommended dimensions or weights may affect the vehicle's overall centre of gravity and stability. From 29 April 2013 conversion of N1 vehicles was affected by changes to type approval – for further information refer to the VCA website (N2 vehicles were affected from 29 October 2014). For further information please contact conversions@vauxhall.co.uk

All measurements are in mm (inches) unless stated otherwise. Heights shown unladen.

ACCESSORIES

SAFETY Total (exc. VAT)

Safety kit (first aid kit, hi-vis vest and warning triangle)	£13
Warning triangle	£7
First aid kit	£12
Hi-vis safety vest – Adult	£3
Emergency seat belt cutter and hammer	£15
Philips ADR620 dash cam	£90

PRACTICAL

Spare bulb kit	£44
Stretch tow rope – 3 tonne	£28
Smoker Pack	£45
Fragrance diffuser	£19
Fragrance cartridge	£14

SECURITY

Rear window grille – H1	£192
Side sliding door (right) window grille – L1	£158
Side sliding door (right) window grille – L2/L3/L4	£167

PROTECTION

Carpet front floor mat	£51
Mudflaps – Set of four – L1/L2	from £102
Rear parking sensors	£228

TRANSPORT SYSTEMS Total (exc. VAT)

Base carrier (set of 2 bars)	
– H1	£286
– H2	£288
Aluminium roof rack tray (including roller)	
– L1 H1	£1,027
Aluminium roof rack tray (including roller)	
– L1 H2	£1,027
Aluminium roof rack tray (including roller)	
– L2 H2	£1,152
Aluminium roof rack tray (including roller)	
– L3 H2	£1,143
Aluminium roof rack tray (including roller)	
– L4 H2	£1,195
Roof rack tray Steel walkway – L1	£277
Roof rack tray Steel walkway – L2	£320
Roof rack tray Steel walkway – L3	£331
Roof rack tray Steel walkway – L4	£351
Roof rack tray black steel walkway – L4	£261
Roof carrier ladder – H1	£273
Roof carrier ladder – H2	£292

Roof Carriers

Thule ladder tilt 311	£498
Thule ladder holder 330	£116
Thule ladder roller 335	£75
Thule front load stop system (side profiles)	£168
Thule front load stop system 321 (front)	£79
Thule ratchet tie down strap	£25
Thule fold down load stop 315	£50
Thule square bar adapter	£37

TOWING

Flange tow bar with 13-pin electrics	from £528
--------------------------------------	-----------

GLOSSARY OF TERMS

Plated weight

The maximum weight to which a vehicle or an axle may be loaded, determined either by the design of the components or by legislation. All commercial vehicles must carry a manufacturer's 'plate' showing the vehicle and axle gross 'plated weights'. It is an offence to drive a vehicle in a condition where any of these weights are exceeded.

Minimum Mass

Minimum Mass ('Mass in running order' on Certificate of Conformity and 'Mass in Service' on V5C form) is defined according to European Type Approval and include all fluids, tools and 90% fuel load. It is minimum mass for this variant and does not consider local specification/trim or deletable options (specific to Movano). Weights are also subject to manufacturing tolerances (EU Legislation allows 5% tolerance).

Gross Vehicle Weight (GVW)

The total permissible weight of a vehicle including payload and passengers, as shown on the manufacturer's plate.

Gross Combination Weight (GCW)

The maximum permissible weight of a vehicle, including payload and passengers, combined with the total weight of any trailer it is towing. The maximum GCW weight limit is quoted on the vehicle plate and must not be exceeded.

Payload

The total permissible weight that can be carried without exceeding the vehicle's plated weight. Payload do not include driver but do take into consideration specification/trim level:

Weights are also subject to manufacturing tolerances (EU Legislation allows 5% tolerance). Payload does not consider any additional options that a customer may order.

Roof loads

- Combo roof load should not exceed 100kg including the weight of the roof rack/carrier
- Vivaro roof load should not exceed 170kg including the weight of the roof rack/carrier
- Movano roof load should not exceed 200kg (150kg on H1 models) including the weight of the roof rack/carrier. H3 are not permitted to carry roof loads

Maximum towing weight

The maximum weight of any trailer and its load which may be towed within the limit of the vehicle's plated Gross Combination Weight (GCW). It is based on the ability of the vehicle – at full GCW – to restart on a 12% gradient, which is approximately 1 in 8.3, at sea level. At altitudes above 1500 metres, the engine output may drop with a corresponding reduction in towing capability. It is the operator's responsibility to ensure that the trailer noseweight does not cause the rear axle plated weight of the towing vehicle to be exceeded.

Always fit Vauxhall towing attachments and accessories available from your Vauxhall Commercial Vehicle Retailer. They are designed specifically for Vauxhall models and carry a 12-month warranty.

Light Duty and Heavy Duty cycles

For a Light Duty cycle (EC regulation 715/2007 with designation 'Euro 6') the emissions of the whole vehicle are evaluated whereas for Heavy Duty cycle (EC regulation 595/2009 with designation 'Euro VI') only the engine is bench tested. The requirement of which cycle is necessary is determined by the reference mass of the vehicle. In the case of Movano, reference mass calculations dictate that:

- N1 FWD and M1 FWD are approved as Light Duty
- N1 RWD, N2 RWD and M2 FWD are approved as Heavy Duty

Conversions

With Vivaro a new conversion portal is introduced. This significantly improves the transparency and response of all communication with body-builders, and converters:

www.converters-and-groupe-psa.com

This website contains complete technical guidelines necessary to convert Vauxhall commercial vehicles – Combo (K9), Vivaro (K0) and Movano (X62). All vital and fundamental information is now located in one place:

- Conversion Guidelines
- Technical Data
- 3D CAD (coming)
- WLTP guidance
- Body shell ordering

Additionally there is a new Q&A service for technical questions, and the new conversion approval process will also be managed through this portal.

Any converter of Vauxhall product should create an account on this portal including those using IVA as approval process. In fact WLTP will make this necessary.

Commercial Vehicle Categories

Differences between M1/N1 and M2/N2 (Vehicles with GVW above 3500kg)

Category M: Passenger carriers

Category M1: Vehicles designed and constructed for the carriage of passengers and comprising no more than eight seats in addition to the driver's seat.

Category M2: Vehicles designed and constructed for the carriage of passengers, comprising more than eight seats in addition to the driver's seat, and having a maximum mass not exceeding 5 tonnes.

Category N: Goods vehicles

Category N1: Vehicles designed and constructed for the carriage of goods and having a maximum mass not exceeding 3.5 tonnes.

Category N2: Vehicles designed and constructed for the carriage of goods and having a maximum mass exceeding 3.5 tonnes but not exceeding 12 tonnes.

Specific differences, all M2/N2 require the following:

Speed limiter: All M2/N2 vehicles are legally required to be speed limited. M2 to 62mph and N2 to 56mph.

GLOSSARY OF TERMS

Driver licence: Commercial vehicles with GVW greater than 3.5 tonnes have different license requirements. For any new drivers C1 category is necessary. Under some circumstances (social purposes for a non-commercial body) it is possible to drive a minibus without a D1 entitlement (Minibus) however eligibility for this exemption should be confirmed with DVSA.

Driver CPC: Driver Certificate of Professional Competence mandates 35 hours of periodic training every 5 years to maintain licence (from September 2014).

Tachograph: It is a legal requirement to administer the activities of drivers subject to the EU or AETR drivers' hours rules, and also record the vehicle's speed, distance and time. A Smart Card is required for digital tachograph and these are available from the DVLA. The tachograph of a new vehicle must be calibrated within two weeks of first registration.

Operator's Licence: This may also be required to ensure that vehicles are kept safe and in good condition at all times. Specifically for M2, PSV (public service vehicle) operator's licence is required. Exemptions in some circumstances may be permitted but this should always be confirmed with DVSA.

MOT Testing: M2/N2 must be tested each year, and vehicle presented with a completed Certificate of Conformity (CoC). This is available from Vauxhall (regdata@gm.com) or from converter in case of second-stage conversion.

Conversions - WLTP

There is a mandatory CO₂ target that comes into effect in 2020. There are specific targets for both cars and light commercial vehicles. With respect to LCVs, Vauxhall will be responsible for the CO₂ of complete converted vehicle, and defined Maxi-Pollutant Values must be respected. These values are:

- Mass in Running Order (kg)
- Frontal Surface (m²)
- Rolling Resistance Coefficient of tyres (kg/t)
- Air Inlet Surface to cool the engine (dm²)

Conversion Guidelines; Maxi-Pollutant Values and links to CO₂ calculator can all be found on the converter portal at www.converters-and-groupe-psa.com

Second-stage conversions based on a Euro 6D TEMP engine cannot be registered unless they have passed the CO₂ calculator. If Maxi-Pollutant values are not followed, then CO₂ calculation will fail and converted vehicle cannot be registered. It would be necessary then to change the conversion.

Process change: All vehicles with heavy duty engines to be ordered with WLTP (QYI/QXI/QWI)

- If RM>2610kg, CoC will reflect NEDC automatically
- In case of incomplete versions, at 2nd stage approval NEDC to be assumed if RM >2610kg

Movano engine selection

	Euro 6D Temp Road Load Matrix (RLM) FWD only	Euro 6D Temp Default Road Load FWD only	Euro VID WLTP RWD or FWD
	-	-	XYEP
Low - Manual	QJI 135	QMI 135	QWI 130
Middle - Manual	Q96 150	QZI 150	QXI 145
High - Manual	QVI 180	QUI 180	QYI 165
High - MTA	QBF 180	QFF 180	N/A
Minimum Reference Mass	-	-	2380
Maximum Reference Mass	2610	2840	2610
Maximum Front Area	No change allowed	7.48m ²	8.23m ²
Minimum air-intake area	0.155m ²	0.155m ²	0.155m ²
Rolling Resistance	6.68 Kg/t	6.68 Kg/t	6.68 Kg/t

Reference Mass = unladen vehicle (90% fuel; all fluids; no driver) + conversion + 100kg.

FURTHER INFORMATION

Vauxhall on-the-road recommended retail prices (RRP)

To eliminate uncertainty about hidden costs incurred when buying a new commercial vehicle, Vauxhall publishes on-the-road prices and these are shown in the pricing tables within this price guide. The prices shown are manufacturer's recommended retail prices (RRP) unless otherwise stated, exclusive of VAT (currently at a rate of 20% which may be payable). These prices include the recommended cost of number plates, delivery to a Vauxhall Retailer of £583.33 (£700.00 including VAT), 12 months' Government Vehicle Excise Duty* and the DVLA new vehicle first registration fee of £55.00*.

Please note: The RRP does not include fuel supplied by the Retailer, motor insurance or any other goods or services supplied by agreement between the Retailer and customer.

Price protection for all Vauxhalls

Order a new Vauxhall for build in the current model year (as confirmed by your Retailer) for delivery no more than three months in advance and the price you are quoted is the price you pay. This is irrespective of any subsequent price rises between placing your order and delivery of your new commercial vehicle, but you must take delivery as soon as the commercial vehicle is available. Vauxhall Motors Limited is not liable for price adjustments caused by Government changes in the rate of VAT (currently 20%), Vehicle Excise Duty, DVLA new vehicle first registration fee or by any other applicable legislation or regulations.

In the event of an accident...

Vauxhall Accident Management helps keep you mobile following an accident. Benefits include vehicle recovery, Vauxhall-approved repairs and contacting your insurer. For more details, visit www.vauxhall.co.uk/AccidentManagement

Vehicle Excise Duty

The amount of Vehicle Excise Duty (road fund licence) payable on new commercial vehicles varies depending on gross vehicle weight (GVW) and European standard emissions compliance, as shown below*.

Up to 3500kg GVW	£265.00
Over 3500kg GVW	£165.00

*Correct at time of publication.

Customer Care Commitment

For added peace of mind, Vauxhall has an innovative Customer Care Commitment** that offers the following:

- Three-year vehicle warranty consisting of a one-year/unlimited mileage manufacturer's warranty and a second and third year manufacturer's warranty with a 60,000 miles (Combo) and 100,000 miles (Vivaro and Movano) limitation
- Vauxhall Assistance for 12 months from first registration
- Five years' body panel anti-perforation warranty

**Warranty is only on vehicles sourced from Vauxhall Motors Limited. Terms and conditions apply – please see your Vauxhall Retailer for details.

Vauxhall Assistance

Vauxhall Assistance is provided Automatically with every new Vauxhall Commercial Vehicle for 12 months from first registration and covers everything from accidents, mechanical breakdown to flat tyres. With Vauxhall Assistance help is literally just a free[†] phone call away, 24 hours a day, 365 days a year!

[†]Mobile phone users will be charged at their standard tariff.

Vauxhall Extended Warranty

For complete peace of mind Vauxhall offers an extended warranty that can be purchased on an annual basis following the expiry of the original new vehicle warranty. It covers most mechanical

and electrical components. Terms and conditions apply, for further details please contact your local Vauxhall Retailer.

Protecting the environment

Our products are increasingly winning environmental awards, both through the use of more recycled materials and by becoming cleaner and more efficient. For information on Vauxhall's efforts to achieve an environmentally sustainable future, including information on Design for Recycling, take-back of End-of-Life Vehicles (ELVs), and the recycling of ELVs, see www.vauxhall.co.uk/recycling

Van Business Centres

Keeping your van on the road. We know how important your van is to you, that's why we're geared up to minimise your downtime.

Our nationwide Van Business Centres provide fast, convenient value for money servicing, repairs and MOTs.

- All work is carried out by Vauxhall trained technicians using only genuine parts
- No appointments are required for diagnosis and we offer a 'while you wait' service

We have all the expertise required and will spare no effort to get you back in business as soon as possible.

Vauxhall Service Plan

Vauxhall Retailers offer a great service for owners of all Vauxhall vehicles. Value for money, regular offers and free check-ups, combined with the peace of mind that comes from using Vauxhall-trained technicians and genuine parts, help keep your vehicle in peak condition at all times. Every Vauxhall Retailer supports our customer promise:

We are Vauxhall experts

- Fully Vauxhall-trained technicians
- We use Vauxhall approved diagnostic equipment and specialist tools
- Full access to Vauxhall repair databases and technical centres

We are transparent

- Our invoicing will clearly set out the work at the price agreed with no hidden extras

We are never beaten on price

- We will match any written like for like service/repair quote from a local^{††} competitor using genuine repair methods and parts

We are convenient

- Flexible booking times to suit you
- 'One-stop shop' for every type of Vauxhall service
- While you wait facility on stocked tyres, batteries and exhausts
- Free courtesy vehicle or local collection with annual services and warranty work

We are thorough

- 25 point safety check with any workshop visit
- No obligation advice on essential and non-essential work
- Free check for safety enhancements and upgrades to your vehicle and software
- Free 'Wash and Vac' with every annual service
- Free fitting of wipers and external bulbs with annual services

^{††}A radius of five miles/20 minutes from your Vauxhall Retailer.

For more product information

For further information on the Vauxhall range or location of your nearest Vauxhall Retailer please call 0345 600 1500. Alternatively, details can be found on our website at www.vauxhall.co.uk

For more information call **0345 600 1500**

Discover the full Vauxhall range at **[vauxhall.co.uk](https://www.vauxhall.co.uk)**

Join us online

The invoice price, including delivery to Retailer, factory-fitted options, accessories fitted by the Retailer and number plates, is subject to VAT. Some feature descriptions in this guide may refer to, and some illustrations may show, optional equipment not included in the standard delivery. The information contained in this guide was accurate at the time of publication. We reserve the right to make changes in design and equipment. Please note that Vauxhall Retailers are not the agents of Vauxhall Motors Limited and are not authorised to bind Vauxhall Motors Limited by any specific or implied undertaking or representation. It is advisable to ensure that your motor insurance policy provides adequate cover for additional fitted options and accessories. The colours in this guide are only approximate actual colours.

Illustrated optional equipment is available at extra charge. Availability, technical features and equipment provided on our vehicles can vary by model. For precise information on the equipment provided on our vehicles, please contact your local Vauxhall Retailer.

VAUXHALL